

Measurement • Protection • Advancement

Since 1935

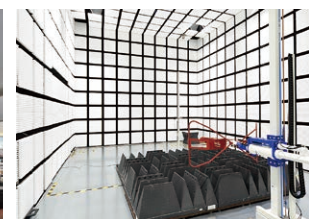
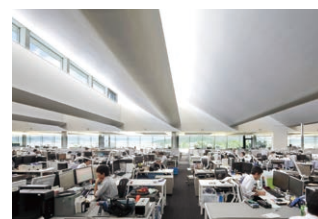

In our mission to provide measurement technologies that protect the safety of society, we seek to contribute to the advancement of a brighter and more prosperous future.

Hioki's measurement technology is widely used in the maintenance, repair and operation of factories, businesses and infrastructures, contributing to the safety and security of our daily lives.

We also support the development of next generation technologies in the automotive and new energy sectors by delivering high quality instruments at a reasonable cost.

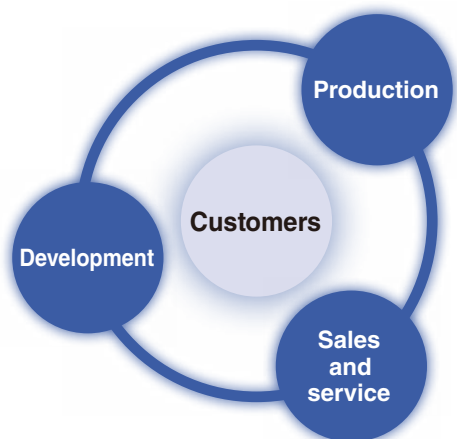

Founded in 1935, Hioki has grown to become a world leader in providing consistent delivery of tests and measuring instruments. By integrating both R&D and manufacturing in a central facility, we succeed in implementing a fully sustainable end-to-end product innovation life cycle to deliver instruments characterized by precision, safety, and quality to customers around the world.

HIOKI, an R&D-focused company

Technology advances on a daily basis, making possible safer and more comfortable human lifestyles and helping make dreams come true. The measuring instruments that underpin these advances also continue to evolve. To develop electrical measuring instruments that meet the changing needs of our times, one-third of all HIOKI employees work in research and development, an area where we invest approximately 10% of all revenue.

Pursuing agile production

HIOKI works to implement optimal production structures that are capable of meeting changing market needs with high-quality products. Due to the nature of electrical measuring instruments, which serve as yardsticks for measuring electricity, it is necessary to ensure a high level of quality in their production. Working with the cooperation of suppliers, we continuously strive to ensure our manufacturing operations conform to the world's highest standards of product quality.

Practicing customer-centric sales

Working with distributors, we actively visit customers to resolve their concerns. Information obtained during these visits is also utilized in product development, laying the groundwork for our ability to create products that satisfy our customers.

Contents

About the Catalog	p. 2
Applications Factory	p. 4
Applications Data Centers	p. 6
Applications Residences & Commercial Buildings	p. 8
Manage Measurement Data on Tablets and PCs	p. 10
Calibration and Repair Service	p. 60

Clamp Meters	pp. 12-21	Clamp
Insulation Testers	pp. 22-27	Insulation
DMMs	pp. 28-35	Tester
Phase Detectors Voltage Detectors	pp. 36-37	Detectors
Earth Testers	pp. 38-43	Earth
Power Quality Analyzers	pp. 44-45	Power quality
Power Loggers	pp. 46-47	Power loggers
Battery Testers	pp. 50-51	Battery
PV Maintenance	pp. 52-53	PV
Data Loggers	pp. 54-56	Logger
LAN Cable Testers	p. 57	LAN
Lux Testers	p. 58	Lux
Temperature Testers	p. 58	Temperature
Resistance Meters	p. 59	Resistance

About the Catalog

About the Marks



Compliant with CE



Compliant with CSA



New product



*Android, Google Play and the Google Play logo are trademarks of Google Inc.

*iOS is a registered trademark of Cisco Technology, Inc. and/or its affiliates in the United States and certain other countries.

*iPhone, iPad, iPad mini, iPad Pro and iPod touch are trademarks of Apple Inc.

*Apple and the Apple logo are trademarks of Apple Inc. App Store is a service mark of Apple Inc.

*Microsoft, Windows, Windows 11, Windows 10, and Excel are either registered trademarks or trademarks of Microsoft Corporation in the United States and/or other countries.

*Company names and Product names appearing in this catalog are trademarks or registered trademarks of various companies.

*The Bluetooth® word mark and logos are registered trademarks owned by Bluetooth SIG, Inc. and any use of such marks by HIOKI E.E. CORPORATION is under license.

*For the latest information about countries and regions where wireless operation is currently supported, please visit the Hioki website.

	Safety standard measurement categories*
	Drop proof Robust design capable of withstanding a drop from a height of 1 m onto concrete
	Backlight
	Auto power OFF Automatically turns off after a certain time
	Display hold
	True RMS True RMS measurement for accurate measurement of even distorted current waveforms
	Low-pass filter Cuts high frequency content to provide stable numerical values for measurement
	AUTO AC/DC Automatically detects and measures AC and DC voltage
	Decibel conversion Displays AC voltage measurements converted to decibel values (dbm/dbv)
	MAX/MIN/AVG value* Displays the maximum, minimum, and average of the displayed values
	Peak measurement* Displays the wave maximum and minimum peak values
	Relative display Pressing the REL button displays subsequent measurements as values relative to that displayed when the button was pressed
	Current sensor can be connected
	Flexible current sensor can be connected

	AC voltage
	DC voltage
	DCV + ACV
	Frequency
	Resistance
	Capacitance
	Temperature
	ACA current
	DCA current
	DCA + ACA
	DC Power
	Continuity check Buzzer sounds when continuity is detected
	Diode check Displays voltage if in the correct direction, and OVER if in the reverse direction
	Voltage detection Buzzer sounds when AC voltage is detected
	Inrush (rush current) Measures inrush current when power is turned on, etc.





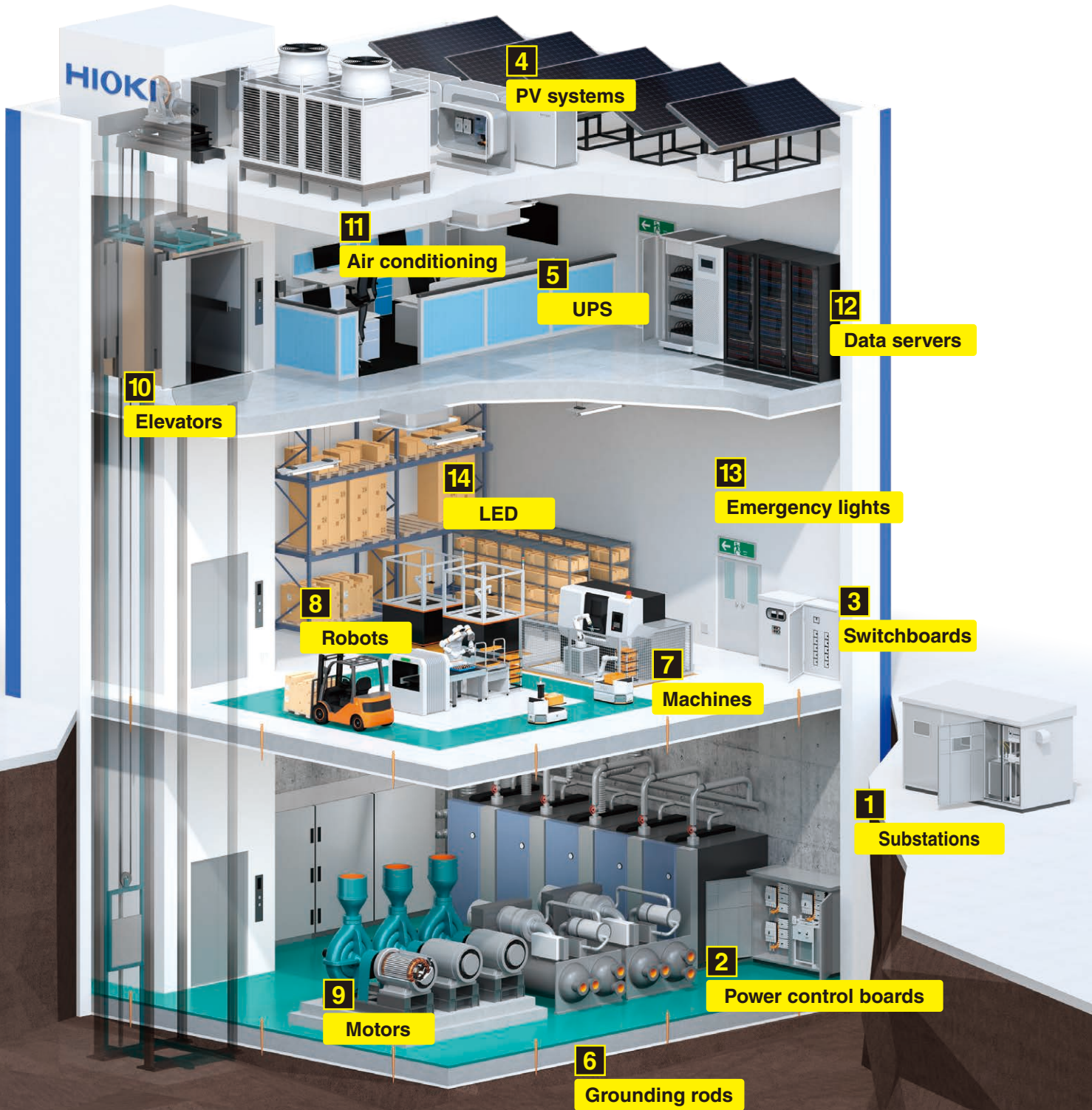



*For more detailed information, please refer to the next page.

Applications Factory









1 2 3

Power Receiving and Transforming Equipment, Power Control Boards, Switchboards

Verify phase rotation	Test insulation	Test supply voltage	Verify load current	Detect leakage current	Detect electrical disturbances, Analyze power quality	Record and analyze electrical consumption	Test 5 kV insulation
							
p.36	p.22	p.28	p.12	p.12	p.44	p.46	p.22

4

PV Systems

Test bypass diodes	Test PV insulation	Verify string voltage	Verify string voltage	Verify string current	Test battery resistance and voltage	Verify grounding
						
p.52	p.22	p.28	p.12	p.12	p.50	p.38

5







UPS

6

Earth, Ground

7 8 9

Machines, Robots, Motors







Test supply voltage	Test load current	Check temperature	Verify motor insulation	Test supply voltage	Test load current	Verify phase rotation
						
p.28	p.12	p.58	p.22	p.28	p.12	p.36

10

Elevators

11

Air Conditioning

Check temperature and humidity	Check temperature	Test insulation	Test supply voltage	Test load current	Verify LAN wiring	Measure illuminance
						
p.54	p.58	p.22	p.28	p.12	p.57	p.58

12

Servers

13 14

Emergency Lights





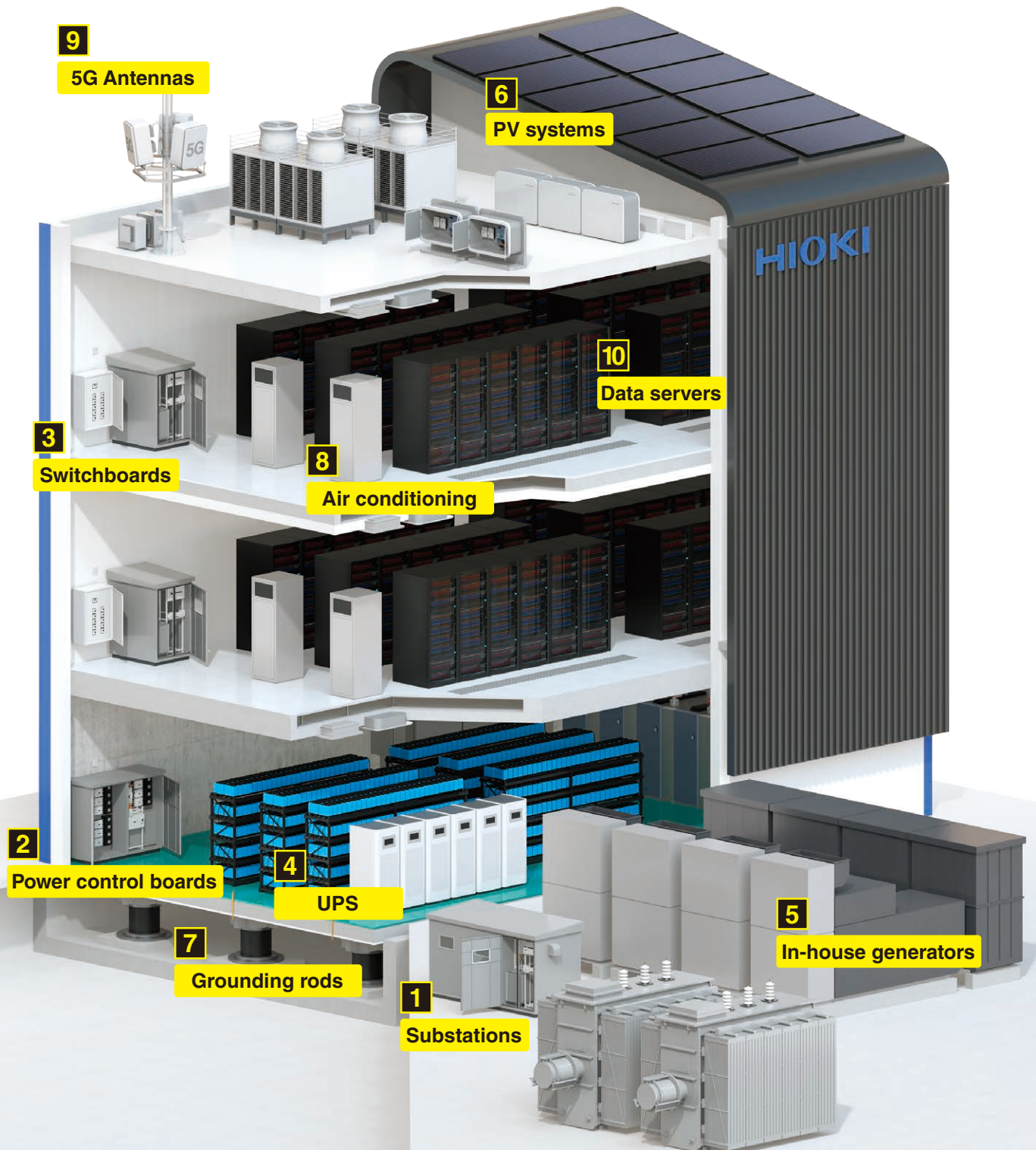



Applications

Data Centers



1 2 3

Power Receiving and Transforming Equipment, Power Control Boards, Switchboards





<p>Verify phase rotation</p>  <p>p.36</p>	<p>Test insulation</p>  <p>p.22</p>	<p>Test supply voltage</p>  <p>p.28</p>	<p>Verify load current</p>  <p>p.12</p>	<p>Detect leakage current</p>  <p>p.12</p>	<p>Detect electrical disturbances, Analyze power quality</p>  <p>p.44</p>	<p>Record and analyze electrical consumption</p>  <p>p.46</p>	<p>Test 5 kV insulation</p>  <p>p.22</p>
---	---	---	---	--	--	---	--

4

UPS

5

Power Generators







<p>Test battery resistance and voltage</p>  <p>p.50</p>	<p>Verify motor insulation</p>  <p>p.22</p>	<p>Test supply voltage</p>  <p>p.28</p>	<p>Test load current</p>  <p>p.12</p>	<p>Verify phase rotation</p>  <p>p.36</p>
---	---	---	---	---

6

PV Systems

7

Earth, Ground







<p>Test bypass diodes</p>  <p>p.52</p>	<p>Test PV insulation</p>  <p>p.22</p>	<p>Verify string voltage</p>  <p>p.28</p>	<p>Verify string voltage</p>  <p>p.12</p>	<p>Verify string current</p>  <p>p.12</p>	<p>Verify grounding</p>  <p>p.38</p>
--	--	---	---	---	---

8 9

Air Conditioning, 5G Antennas

10

Servers

<p>Check temperature and humidity</p>  <p>p.54</p>	<p>Check temperature</p>  <p>p.58</p>	<p>Test insulation</p>  <p>p.22</p>	<p>Test supply voltage</p>  <p>p.28</p>	<p>Test load current</p>  <p>p.12</p>	<p>Verify LAN wiring</p>  <p>p.57</p>
--	---	---	---	---	--



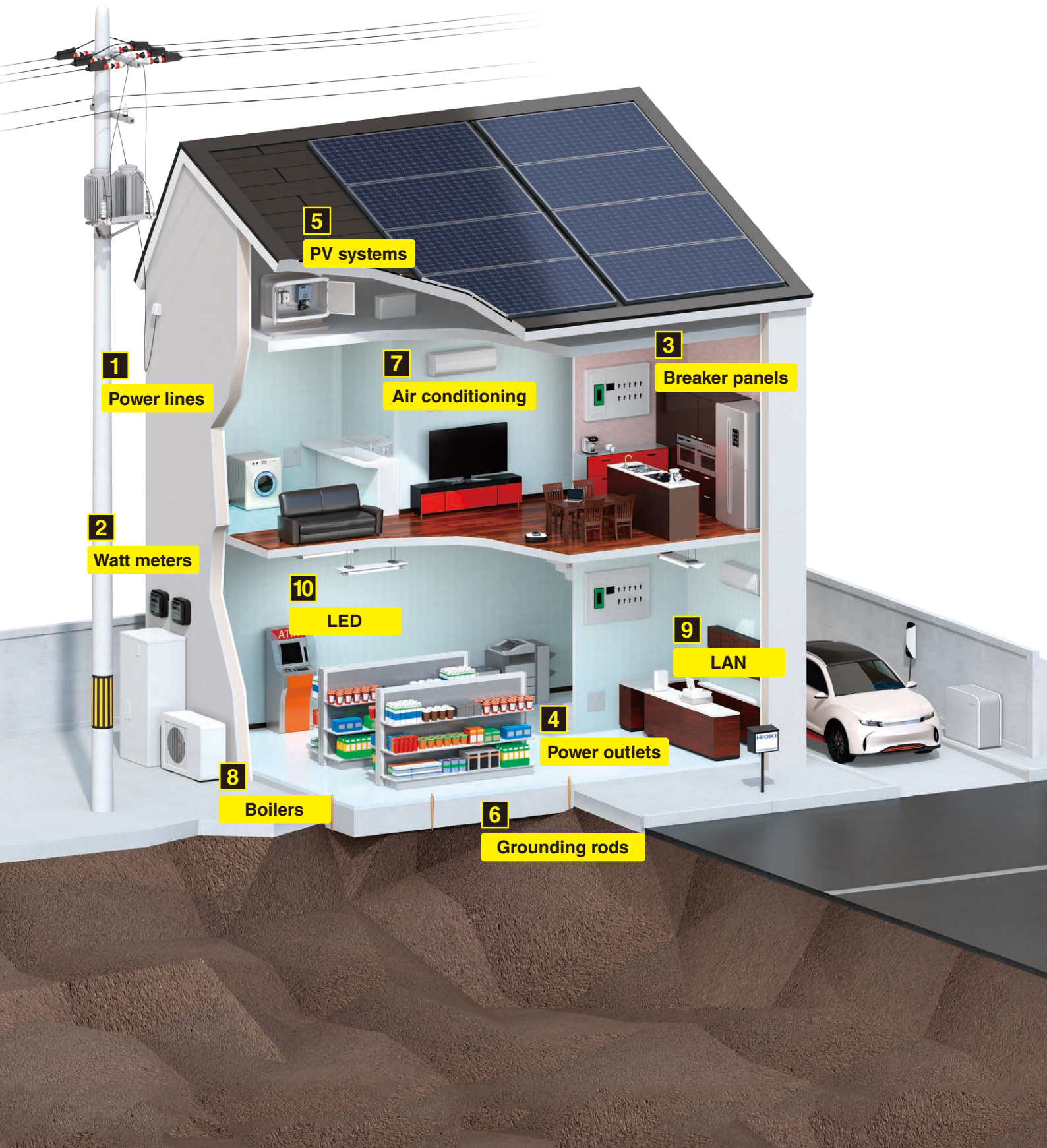

Applications

Residences & Commercial Buildings





1 2 3

Power Lines, Watt Meters, Breaker Panels

Test insulation	Test supply voltage	Verify load current	Detect leakage current	Record and analyze electrical consumption
				
p.22	p.28	p.12	p.12	p.46





4

Power Outlets

Verify absence of voltage	Test supply voltage	Verify load current
		
p.36	p.28	p.12

5

PV Systems

Test bypass diodes	Test PV insulation	Verify string voltage	Verify string voltage	Verify string current
				
p.52	p.22	p.28	p.12	p.12

6







Earth, Ground

Verify grounding

p.38





7

Air Conditioning

Check temperature and humidity	Check temperature	Test insulation	Test supply voltage	Test load current	Detect leakage current
					
p.54	p.58	p.22	p.28	p.12	p.12

8

Boilers

Test insulation	Test supply voltage	Test load current	Detect leakage current
			
p.22	p.28	p.12	p.12

9

LAN

Verify LAN wiring

p.57

10

LED

Measure illuminance

p.58

Manage Data on Mobile Devices and PC



for mobile devices
Gennect Cross



Gennect Cloud expands your potential.

Gennect Cross
Dedicated website



Checking and saving measured values

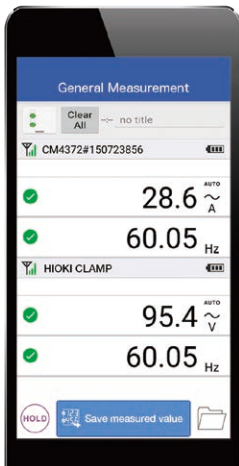

The measurement values displayed on the instrument can be displayed and saved on the tablet in real time.

Record fluctuations in measured values

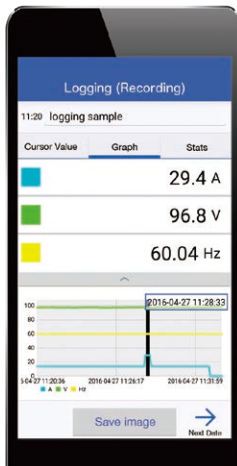

Measurement values can be saved at set recording intervals. You can also check the maximum, minimum, and average values.

Waveform observation, FFT analysis



Waveforms such as current and voltage, and FFT analysis waveforms can be displayed.

Record on photos and drawings



Measurements can be recorded on top of captured photos or imported drawing data.

Report writing

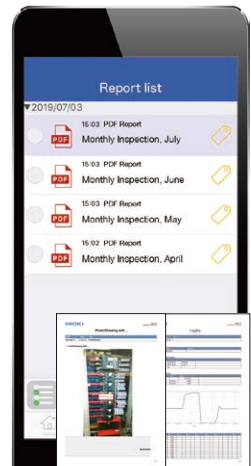

You can create reports from saved data, exporting them as PDF, JPG, or CSV.

Display judgment results in color and bar graph

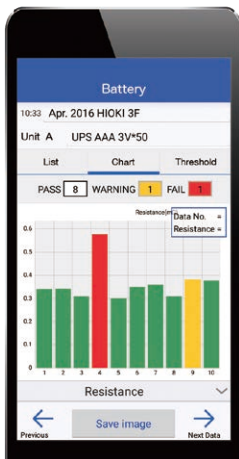

The measured value is compared with the judgment value, and the result is displayed in PASS/WARNING/FAIL.

Check power quality by analyzing harmonics up to the 30th order

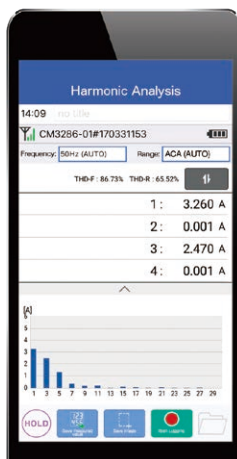

Calculate and display harmonic levels for individual orders, content percentages, and total harmonic distortion (THD-F and THDR).

Record the occurrence of intermittent leakage current

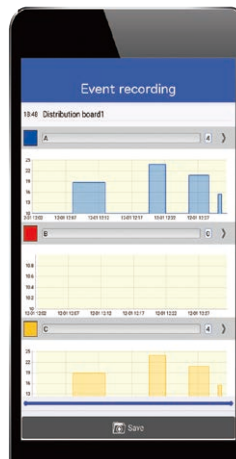

When a value greater than the threshold is measured, the time of occurrence, end time, and the maximum value for that period are recorded.

Display of disequilibrium rates and vector diagrams



Displays the disequilibrium rate and vector diagram.

Audio guidance about the battery measurement sequence

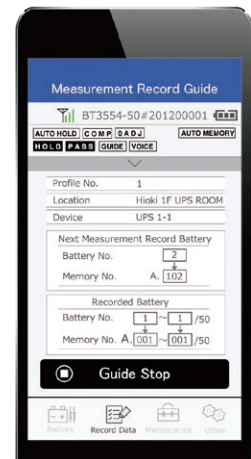

The app provides audio guidance about the battery measurement sequence. And, automatically saves the measurement results.

Supported instruments (available functions vary depending on the measurement device. For details, please visit the Gennect Cross special website.)

Wireless adapter Z3210 (optional) must be attached to use Gennect Cross.

WIRELESS ADAPTER Z3210	RM3548-50	IR4059	IR4057-50	IR5050, IR5051	DT4261	FT6041	FT6031-50	FT6380-50	PD3259-50	FT3425
	BT3554-50	CM4371-50	CM4373-50	CM4375-50	CM4141-50	CM3286-50	CM4001	CM4002	CM4003	FT4310

Downloading Gennect Cross

Data can be downloaded to tablets and smartphones using Hioki's dedicated apps available from the Google Play™ or App Store. Search for "HIOKI" and download the "Gennect Cross" app.



for PCs Gennect One



Gennect Cloud expands your potential.

Gennect One
dedicated website

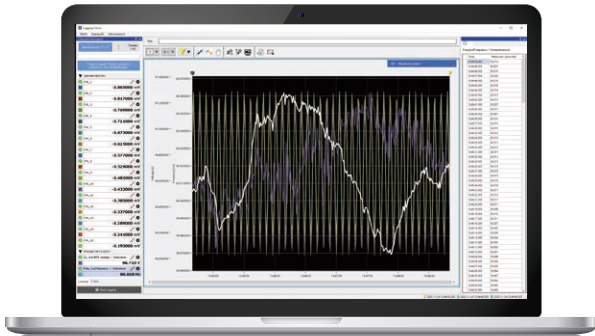

HUB

Connect each measuring instrument with LAN cable (BT3554-50 series is USB connection)

<p>Power Analysis</p>	<p>Monitoring Power Quality</p>	<p>Understanding Power Consumption</p>
<p>Voltage and temperature management</p>	<p>Waveform Analysis</p>	<p>UPS Inspection</p>



Connect To and Manage Instruments With a Computer

Collect and display measured values by instrument

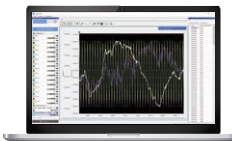

Collect values in graphs and lists

Logging: When logging is started, measurement data is acquired at regular intervals from multiple measuring instruments. The acquired data is displayed and stored on the PC in real time.



Combine images and other elements

Dashboard: Create a dashboard by laying out measurements, background images, and other parts on the screen. You can display the measured values on the dashboard in real time.

Change instrument settings from your office



Change instrument settings from a computer

Remote control: Available to change the settings of the instrument and start and stop the measurement from the PC.
Instrument clock synchronization: The clock of the measuring instrument can be synchronized with the PC clock.

Collect and organize measurement files from scattered locations

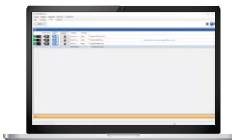

Transfer measurement files to a computer

Automatic file transfer: Measurement data stored in the instrument can be automatically transferred to the PC.
Data import: The measurement data stored in the instrument can be transferred to the PC manually.

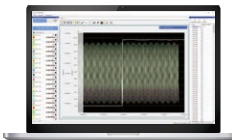

Review acquired files on a single time axis

Time-series viewer: After acquiring the measurement data stored in the main unit of the instrument, the data can be checked in a single time series.

Supported instruments (available functions vary depending on the measurement device. For details, please visit the Gennect One special website.)

PW8001 PW6001 PW4001 PW3390	PW3335 PW3336 PW3337	PQ3198 PQ3100	PW3365 PW3360	LR8101 LR8102	LR8450 LR8450-01	BT3554-50	LR5001 LR5011 LR5021 LR5031 LR5041 LR5042 LR5043 LR5051 LR5061
IM3523A	RM3545A	BT4560-50	BT6065 BT6075	BT5525	DM7275 DM7276	MR6000	

Downloading Gennect One

Gennect One is a free PC application. Please download from the HIOKI website by going to the "Gennect One" landing page.



CLAMP METERS

Remarkable Ease of Use, New "Slim Jaw" Design

Traditional design



Slim jaw



Easily clamp within crowded cables with new slim jaw design

Innovative slim jaw resolves worksite issues such as crowded wiring to deliver safe, accurate and high-performance testing.



CM4375-50

CM4141-50

CM3289

CM3281
CM3291

CM4001

Manage Measurement Data Using Z3210^{*1}

Bluetooth®

WIRELESS ADAPTER Z3210 (option)

Attach to enable Bluetooth® wireless technology

Transport to the Excel® file

Open an Excel® file and select a cell. The measured value being held on the instrument's display will be transferred to the computer and entered into the selected cell.

Learn more Z3210

Transport to Gennect Cross

Gennect Cross, a free app designed specifically for use with Hioki measuring instruments, lets you check and manage measurement results and create reports. The software provides a range of functionality that helps manage data in the field, including photographing measurement sites, placing measurement results on photographs, and saving hand written memos.

Learn more Gennect Cross

PDF reports
CSV measurement data
JPG image data

Verify current waveforms on your mobile device

*1: Supported models: CM4371-50, CM4373-50, CM4375-50, CM4141-50, CM4001, CM4002, CM4003, CM3286-50 (requires attaching WIRELESS ADAPTER Z3210)

Safe PV Measurement Using P2010^{*2}

Available to measure 2000 V DC
DC HIGH VOLTAGE PROBE P2010 (option)

CAT IV 1000 V
CAT III 2000 V



CM4371-50



CM4373-50

CM4375-50

CM4141-50

*2: Supported models: CM4371-50, CM4373-50, CM4375-50, CM4141-50 (requires using DC HIGH VOLTAGE PROBE P2010)

Lineup





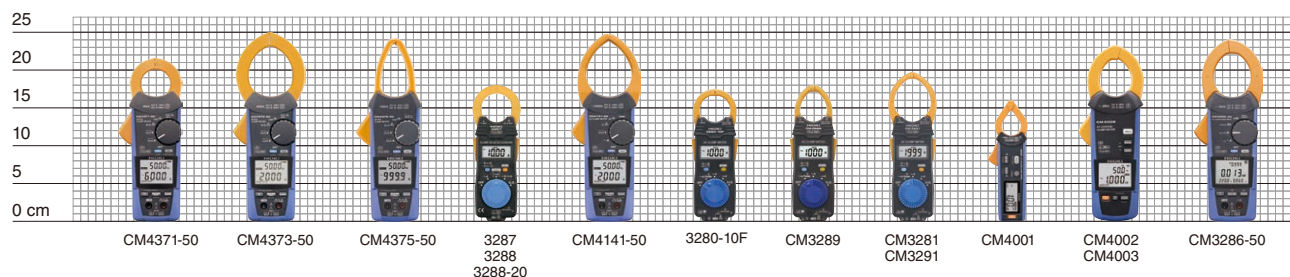



Measurement type	AC/DC current					
Model	CM4371-50	CM4373-50	CM4375-50	3287	3288 3288-20	
Appearance						
Core jaw diameter	Φ33 mm (1.30 in.)	Φ55 mm (2.17 in.)	Φ34 mm (1.34 in.)	Φ35 mm (1.38 in.)	Φ35 mm (1.38 in.)	
AC measurement system	True RMS	True RMS	True RMS	True RMS	Mean value (3288) True RMS (3288-20)	
Frequency characteristics	10 Hz to 1 kHz	10 Hz to 1 kHz	10 Hz to 1 kHz	10 Hz to 1 kHz	10 Hz to 500 Hz	
Measurement parameters	AC current (resolution) Guaranteed accuracy range	600 A (0.01) 1 A to 600 A	2000 A (0.1) 1 A to 2000 A	1000 A (0.1) 1 A to 999.9 A	100 A (0.01) Full display range ⁵	1000 A (0.1) Full display range ⁵
	DC current (resolution)	600 A (0.01)	2000 A (0.1)	999.9 A (0.1)	100 A (0.01)	1000 A (0.1)
	AC Voltage	1000 V	1000 V	1000 V	600 V	600 V
	DC Voltage	1000 V, 2000 V ¹	1000 V, 2000 V ¹	1000 V, 2000 V ¹	600 V	600 V
	Power	1200 kVA (DC) ¹	4000 kVA (DC) ¹	2000 kVA (DC) ¹	N/A	N/A
	Resistance	6 MΩ	6 MΩ	6 MΩ	42 MΩ	42 MΩ
	Temperature	-40°C to 400°C	-40°C to 400°C	-40°C to 400°C	N/A	N/A
	Electrostatic capacity	✓	✓	✓	N/A	N/A
	Frequency	999.9 Hz	999.9 Hz	999.9 Hz	N/A	N/A
	Rush current	✓	✓	✓	N/A	N/A
	Continuity check	✓	✓	✓	✓	✓
	Diode check	✓	✓	✓	N/A	N/A
	Non-Contact Voltage	✓	✓	N/A	N/A	N/A
Low-pass filter	✓	✓	✓	N/A	N/A	
Auto power off	✓	✓	✓	✓	✓	
Auto range	✓	✓	✓	✓	✓	
Data hold	AUTO/MANUAL	AUTO/MANUAL	AUTO/MANUAL	MANUAL	MANUAL	
Automatic AC/DC detection	✓	✓	✓	N/A	N/A	
MAX/MIN/AVG	✓	✓	✓	N/A	N/A	
Output	N/A	N/A	N/A	N/A	N/A	
Bluetooth® communication	✓ (with Z3210)	✓ (with Z3210)	✓ (with Z3210)	N/A	N/A	
Backlight	✓	✓	✓	N/A	N/A	
Display refresh rate	5 times/s	5 times/s	5 times/s	2.5 times/s	2.5 times/s	
Safety standard category	CAT IV 600 V CAT III 1000 V	CAT IV 600 V CAT III 1000 V	CAT IV 600 V CAT III 1000 V	V: CAT III 300 V A: CAT III 600 V	V: CAT III 300 V A: CAT III 600 V	
Safety standard category (with P2010)	CAT IV 1000 V CAT III 2000 V	CAT IV 1000 V CAT III 2000 V	CAT IV 1000 V CAT III 2000 V	N/A	N/A	
CE	✓	✓	✓	✓	✓	
Dustproof and waterproof	IP20 ² /IP54 ³	IP20 ² /IP54 ³	IP20 ² /IP54 ³	N/A	N/A	
Drop proof	N/A	N/A	N/A	N/A	N/A	
Power supply	LR03 x 2 Alkaline	LR03 x 2 Alkaline	LR03 x 2 Alkaline	CR2032 x 1 Coin type	CR2032 x 1 Coin type	
Dimensions (W x H x D)	65 x 215 x 35 mm 2.56 x 8.46 x 1.38 in.	65 x 250 x 35 mm 2.56 x 9.84 x 1.38 in.	65 x 242 x 35 mm 2.56 x 9.53 x 1.38 in.	57 x 180 x 16 mm 2.24 x 7.09 x 0.63 in.	57 x 180 x 16 mm 2.24 x 7.09 x 0.63 in.	
Weight	340 g, 12.0 oz.	530 g, 18.7 oz.	350 g, 12.3 oz.	170 g, 6.0 oz.	150 g, 5.3 oz.	

Size comparison



*1: Only when DC HIGH VOLTAGE PROBE P2010 is used *2: Voltage measurement in a completely dry condition. When jaw closes. *3: While in storage

*4: When measuring the current in an insulated conductor. Do not use it when wet. *5: Displayed 0 with below 0.06

Measurement type	AC current					Leakage current		AC power	
Model	CM4141-50	3280-10F	CM3289	CM3281	CM3291	CM4001	CM4002 CM4003	CM3286-50	
Appearance									
Core jaw diameter	Φ55 mm (2.17 in.)	Φ33 mm (1.30 in.)	Φ33 mm (1.30 in.)	Φ46 mm (1.81 in.)	Φ46 mm (1.81 in.)	Φ24 mm (0.94 in.)	Φ40 mm (1.57 in.)	Φ46 mm (1.81 in.)	
AC measurement system	True RMS	Mean value	True RMS	Mean value	True RMS	True RMS	True RMS	True RMS	
Frequency characteristics	45 Hz to 1 kHz	50/60 Hz	40 Hz to 1 kHz	50/60 Hz	40 Hz to 1 kHz	40 Hz to 1 kHz	15 Hz to 2 kHz	45 Hz to 1 kHz	
Measurement parameters	AC current (resolution) Guaranteed accuracy range	2000 A (0.01) 1 A to 2000 A	1000 A (0.01) 4 A to 1000 A	1000 A (0.01) 4 A to 1000 A	2000 A (0.01) 4 A to 1999 A	2000 A (0.01) 4 A to 1999 A	600 A (0.01mA) 0.6 mA to 600 A	200 A (0.001mA) 0.06 mA to 200 A	600 A (0.001) 0.06 A to 600 A
	DC current (resolution)	N/A	N/A	N/A	N/A	N/A	N/A	N/A	N/A
	AC Voltage	1000 V	600 V	600 V	600 V	600 V	N/A	N/A	600 V
	DC Voltage	1000 V, 2000 V ^{*1}	600 V	600 V	600 V	600 V	N/A	N/A	N/A
	Power	N/A	N/A	N/A	N/A	N/A	N/A	N/A	360 kW (AC)
	Resistance	6 MΩ	42 MΩ	42 MΩ	42 MΩ	42 MΩ	N/A	N/A	N/A
	Temperature	-40°C to 400°C	N/A	N/A	N/A	N/A	N/A	N/A	N/A
	Electrostatic capacity	✓	N/A	N/A	N/A	N/A	N/A	N/A	N/A
	Frequency	999.9 Hz	N/A	N/A	N/A	N/A	999.9 Hz	2000 Hz	999.9 Hz
	Rush current	✓	N/A	N/A	N/A	N/A	✓	✓	N/A
	Continuity check	✓	✓	✓	✓	✓	N/A	N/A	N/A
Diode check	✓	N/A	N/A	N/A	N/A	N/A	N/A	N/A	
Non-Contact Voltage	N/A	N/A	N/A	N/A	N/A	N/A	N/A	N/A	
Low-pass filter	✓	N/A	N/A	N/A	N/A	✓	✓	N/A	
Auto power off	✓	✓	✓	✓	✓	✓	✓	✓	
Auto range	✓	✓	✓	✓	✓	✓	✓	✓	
Data hold	AUTO/MANUAL	MANUAL	MANUAL	MANUAL	MANUAL	AUTO/MANUAL	AUTO/MANUAL	AUTO/MANUAL	
Automatic AC/DC detection	✓ (voltage only)	N/A	N/A	N/A	N/A	N/A	N/A	N/A	
MAX/MIN/AVG	✓	N/A	N/A	N/A	N/A	✓	✓	✓	
Output	N/A	N/A	N/A	N/A	N/A	N/A	✓ (CM4003 only)	N/A	
Bluetooth® communication	✓ (with Z3210)	N/A	N/A	N/A	N/A	✓ (with Z3210)	✓ (with Z3210)	✓ (with Z3210)	
Backlight	✓	N/A	N/A	N/A	N/A	✓	✓	✓	
Display refresh rate	5 times/s	2.5 times/s	2.5 times/s	2.5 times/s	2.5 times/s	5 times/s	5 times/s	2 times/s	
Safety standard category	CAT IV 600 V CAT III 1000 V	V: CAT III 300 V A: CAT IV 300 V	V: CAT III 300 V A: CAT IV 300 V	V: CAT III 300 V A: CAT IV 300 V	V: CAT III 300 V A: CAT IV 300 V	CAT III 300 V	CAT IV 300 V (CM4002) CAT III 600 V (CM4002) CAT III 300 V (CM4003)	CAT IV 600 V CAT III 1000 V	
Safety standard category (with P2010)	CAT IV 1000 V CAT III 2000 V	N/A	N/A	N/A	N/A	N/A	N/A	N/A	
CE	✓	✓	✓	✓	✓	✓	✓	✓	
Dustproof and waterproof	IP50 ^{*3,4}	IP40 ^{*3}	N/A	N/A	N/A	N/A	IP40	IP20 ^{*2} /IP50 ^{*3}	
Drop proof	N/A	✓	✓	✓	✓	N/A	N/A	N/A	
Power supply	LR03 × 2 Alkaline	CR2032 × 1 Coin type	CR2032 × 1 Coin type	CR2032 × 1 Coin type	CR2032 × 1 Coin type	LR03 × 1 Alkaline	LR6 × 2 Alkaline	LR03 × 2 Alkaline	
Dimensions (W × H × D)	65 × 247 × 35 mm 2.56 × 9.72 × 1.38 in.	57 × 175 × 16 mm 2.24 × 6.89 × 0.63 in.	57 × 181 × 16 mm 2.24 × 7.13 × 0.63 in.	57 × 198 × 16 mm 2.24 × 7.80 × 0.63 in.	57 × 198 × 16 mm 2.24 × 7.80 × 0.63 in.	37 × 160 × 27 mm 1.46 × 6.30 × 1.06 in.	64 × 233 × 36 mm 2.52 × 9.17 × 1.41 in.	65 × 241 × 35 mm 2.56 × 9.49 × 1.38 in.	
Weight	300 g, 10.6 oz.	100 g, 3.5 oz.	100 g, 3.5 oz.	103 g, 3.6 oz.	103 g, 3.6 oz.	115 g, 4.1 oz.	400 g, 14.1 oz.	450 g, 15.9 oz.	

Test leads with an integrated cap for greater convenience and safety



CAT IV 600V, CAT III 1000V

CAT II 1000V



The L9300 test lead with an integrated cap is included as a standard. The finger guard can be easily slid to switch between measurement categories without worrying about losing the cap.

AC/DC Current

AC/DC CLAMP METER CM4371-50, CM4373-50, CM4375-50



Product warranty for 3 years
Accuracy guaranteed for 1 year

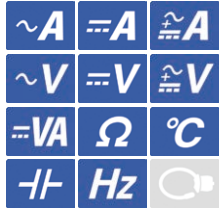

Included accessories



L9300 C0203

- LR03 Alkaline battery × 2
- Instruction manual



WIRELESS ADAPTER
Z3210 (option)
Attach to enable Bluetooth® wireless technology

Φ35 mm = 1.30 in.

CM4371-50
600 A AC/DC
True RMS
CAT IV 600 V
CAT III 1000 V
With P2010
CAT IV 1000 V DC
CAT III 2000 V DC
With Z3210
Bluetooth®
Please see www.hioki.com for list of supported regions.
Gennect Cross

Φ55 mm = 2.17 in.

CM4373-50
2000 A AC/DC
True RMS
CAT IV 600 V
CAT III 1000 V
With P2010
CAT IV 1000 V DC
CAT III 2000 V DC
With Z3210
Bluetooth®
Please see www.hioki.com for list of supported regions.
Gennect Cross

Φ34 mm = 1.34 in.

CM4375-50
1000 A AC/DC
True RMS
CAT IV 600 V
CAT III 1000 V
With P2010
CAT IV 1000 V DC
CAT III 2000 V DC
With Z3210
Bluetooth®
Please see www.hioki.com for list of supported regions.
Gennect Cross



DC HIGH VOLTAGE PROBE
P2010 (option)
Available to measure 2000 V DC

CLAMP ON AC/DC HiTESTER 3287, 3288, 3288-20



Product warranty for 3 years
Accuracy guaranteed for 1 year



Included accessories



L9208 9398

- Coin type lithium battery CR2032 × 1
- Instruction manual

Φ35 mm = 1.38 in.

3287
100 A AC/DC
True RMS
V: CAT III 300 V
A: CAT III 600 V

Φ35 mm = 1.38 in.

3288
1000 A AC/DC
Mean value
V: CAT III 300 V
A: CAT III 600 V

Φ35 mm = 1.38 in.

3288-20
1000 A AC/DC
True RMS
V: CAT III 300 V
A: CAT III 600 V



For more details



Model	CM4371-50	CM4373-50	CM4375-50		Basic accuracy
AC Current	✓	N/A	N/A	20.00 A, 600.0 A (guaranteed accuracy range: 1.00 A to 600.0 A)	±1.3% rdg. ±0.08 A
	N/A	✓	N/A	600.0 A, 2000 A (guaranteed accuracy range: 1.0 A to 2000 A)	±1.3% rdg. ±0.3 A
	N/A	N/A	✓	1000 A (guaranteed accuracy range: 1.0 A to 999.9 A)	±1.3% rdg. ±0.3 A
DC Current	✓	N/A	N/A	20.00 A, 600.0 A (guaranteed accuracy range: ±1.00A to ±600.0 A)	±1.3% rdg. ±0.08 A
	N/A	✓	N/A	600.0 A, 2000 A (guaranteed accuracy range: ±1.0A to ±2000 A)	±1.3% rdg. ±0.3 A
	N/A	N/A	✓	1000 A (guaranteed accuracy range: ±1.0 A to ±999.9 A)	±1.3% rdg. ±0.3 A
AC + DC Current	✓	N/A	N/A	20.00 A, 600.0 A (guaranteed accuracy range: 1.00 A to 600.0 A)	±1.3% rdg. ±0.13 A
	N/A	✓	N/A	600.0 A, 2000 A (guaranteed accuracy range: 1.0 A to 2000 A)	±1.3% rdg. ±1.3 A
	N/A	N/A	✓	1000 A (guaranteed accuracy range: 1.0 A to 999.9 A)	±1.3% rdg. ±1.3 A
AC Voltage	✓	✓	✓	6.000 V, 60.00 V, 600.0 V, 1000 V	±0.9% rdg. ±0.003 V
DC Voltage	✓	✓	✓	600.0 mV, 6.000 V, 60.00 V, 600.0 V, 1000 V, 2000 V ²	±0.5% rdg. ±0.5 mV
AC + DC Voltage	✓	✓	✓	6.000 V, 60.00 V, 600.0 V, 1000 V	±1.0% rdg. ±0.013 V
DC Power	✓	N/A	N/A	0.0 VA to ±1200 kVA ²	±2.0% rdg. ±20 dgt.
	N/A	✓	N/A	0.000 kVA to ±4000 kVA ²	±2.0% rdg. ±20 dgt.
	N/A	N/A	✓	0.000 kVA to ±2000 kVA ²	±2.0% rdg. ±0.020 kVA
Resistance	✓	✓	✓	600.0 Ω, 6.000 kΩ, 60.00 kΩ, 600.0 kΩ, 6.000 MΩ	±0.7% rdg. ±0.5 Ω
Temperature	✓	✓	✓	-40.0°C to 400.0°C	±0.5% rdg. ±3.0°C
Electrostatic capacity	✓	✓	✓	1.000 μF, 10.00 μF, 100.0 μF, 1000 μF	±1.9% rdg. ±0.005 μF
Frequency	✓	✓	✓	9.999 Hz, 99.99 Hz, 999.9 Hz	±0.1% rdg. ±0.003 Hz

Display refresh rate	5 times/s ³
Operating temperature	-25°C to 65°C, 90% RH or less (non-condensating)
Storage temperature	-30°C to 70°C, 90% RH or less (non-condensating)
Dustproof and waterproof	IP20 ⁴ /IP54 ⁵
Power supply	Alkaline battery LR03 × 2
Continuous operating time	40 hours ⁶
Dimensions (W × H × D)	CM4371-50: 65 × 215 × 35 mm (2.56 × 8.46 × 1.38 in.) CM4373-50: 65 × 250 × 35 mm (2.56 × 9.84 × 1.38 in.) CM4375-50: 65 × 242 × 35 mm (2.56 × 9.53 × 1.38 in.)
Weight	CM4371-50: 340 g (12 oz.) CM4373-50: 530 g (18.7 oz.) CM4375-50: 350 g (12.3 oz.)

Order code	CM4371-50	Includes Z3210
Order code	CM4373-50	Order code CM4371-90
Order code	CM4375-50	Order code CM4373-90
Order code	Z3210	Order code CM4375-90
Order code	P2010	Includes Z3210 and P2010
		Order code CM4373-93
		Order code CM4375-93

*1: Excludes CM4375-50
 *2: Only when DC HIGH VOLTAGE PROBE P2010 is used
 *3: Excludes electrostatic capacity, frequency, and temperature
 *4: Voltage measurement in a completely dry condition. When jaw closes.
 *5: While in storage
 *6: With backlight and Bluetooth® communications turned off



Model	3287	3288	3288-20		Basic accuracy
AC Current	✓	N/A	N/A	10.00 A, 100.0 A (display range: 0A to 10.00/100.0 A)	±1.5% rdg. ±5 dgt.
	N/A	✓	✓	100.0 A, 1000 A (display range: 0A to 100.0/1000 A)	±1.5% rdg. ±5 dgt.
DC Current	✓	N/A	N/A	10.00 A, 100.0 A	±1.5% rdg. ±5 dgt.
	N/A	✓	✓	100.0 A, 1000 A	±1.5% rdg. ±5 dgt.
AC Voltage	✓	✓	✓	4.200 V, 42.00 V, 420.0 V, 600 V	±2.3% rdg. ±8 dgt.
DC Voltage	✓	✓	✓	420.0 mV, 4.200 V, 42.00 V, 420.0 V, 600 V	±1.3% rdg. ±4 dgt.
Resistance	✓	✓	✓	420.0 Ω, 4.200 kΩ, 42.00 kΩ, 420.0 kΩ, 4.200 MΩ, 42.00 MΩ	±2.0% rdg. ±4 dgt.

Display refresh rate	2.5 times/s
Operating temperature	0°C to 40°C, 80% RH or less (non-condensating)
Storage temperature	-10°C to 50°C, 80% RH or less (non-condensating)
Dustproof and waterproof	N/A
Power supply	Coin type lithium battery CR2032 × 1
Continuous operating time	25 hours
Dimensions (W × H × D)	57 × 180 × 16 mm (2.24 × 7.09 × 0.63 in.)
Weight	3287: 170 g (6.0 oz.), 3288, 3288-20: 150 g (5.3 oz.)

Order code	3287
Order code	3288
Order code	3288-20

*1: Without 3288

Clamp
 Insulation
 DIMMS
 Detectors
 Earth
 Power quality
 Power loggers
 Battery
 PV
 Logger
 LAN
 Lux
 Temperature
 Resistance

AC Current

AC CLAMP METER CM4141-50



Product warranty for 3 years
Accuracy guaranteed for 1 year



WIRELESS ADAPTER Z3210 (option)
Attach to enable Bluetooth® wireless technology



DC HIGH VOLTAGE PROBE P2010 (option)
Available to measure 2000 V DC

Φ55 mm = 2.17 in.



CM4141-50

2000 A AC

True RMS

CAT IV 600 V
CAT III 1000 V

With P2010

CAT IV 1000 V DC
CAT III 2000 V DC

With Z3210

Bluetooth®

Please see www.hioki.com for list of supported regions.



Included accessories



L9300 C0203

- LR03 Alkaline battery × 2
- Instruction manual

AC CLAMP METER 3280-10F, CM3289, CM3281, CM3291



Product warranty for 3 years
Accuracy guaranteed for 1 year

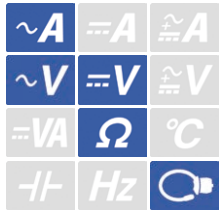

Φ33 mm = 1.30 in.

**3280-10F
3280-70F**

1000 A AC

Mean value

V: CAT III 300 V
A: CAT IV 300 V

9398 (3280-10F) C0205 (3280-70F)



Φ33 mm = 1.30 in.

CM3289

1000 A AC

True RMS

V: CAT III 300 V
A: CAT IV 300 V

9398



Φ46 mm = 1.81 in.

**CM3281
CM3291**

2000 A AC

CM3281: Mean value
CM3291: True RMS

V: CAT III 300 V
A: CAT IV 300 V



CARRYING CASE

Included accessories



L9208

- CARRYING CASE (models vary as shown on right)
- Coin type lithium battery CR2032 × 1
- Instruction manual

Leakage Current

AC LEAKAGE CLAMP METER CM4001, CM4002, CM4003



Product warranty for 3 years
Accuracy guaranteed for 1 year



Φ24 mm = 0.94 in.

CM4001

0.6 mA to 600 A AC

True RMS

CAT III 300 V

Included accessories



CARRYING CASE

- Strap
- LR03 Alkaline battery × 1
- Instruction manual

With Z3210

Bluetooth®

Please see www.hioki.com for list of supported regions.



Φ40 mm = 1.57 in.

CM4002

0.06 mA to 200 A AC

True RMS

CAT IV 300 V
CAT III 600 V

Included accessories



C0203

- LR6 Alkaline battery × 2
- Instruction manual

With Z3210

Bluetooth®

Please see www.hioki.com for list of supported regions.



Φ40 mm = 1.57 in.

CM4003

0.06 mA to 200 A AC

True RMS

CAT III 300 V

Included accessories



C0203 L9097

- LR6 Alkaline battery × 2
- Instruction manual
- USB cable

With Z3210

Bluetooth®

Please see www.hioki.com for list of supported regions.



Functions

- External output
- External power supply



For more details



Model	CM4141-50			Basic accuracy	
AC Current	✓			60.00A, 600.0 A, 2000 A (guaranteed accuracy range: 1.00A to 2000 A)	±1.5% rdg. ±0.08 A
AC Voltage	✓			6.000 V, 60.00 V, 600.0 V, 1000 V	±0.9% rdg. ±0.003 V
DC Voltage	✓			600.0 mV, 6.000 V, 60.00 V, 600.0 V, 1000 V, 2000 V ¹	±0.5% rdg. ±0.5 mV
AC + DC Voltage	✓			6.000 V, 60.00 V, 600.0 V, 1000 V	±1.0% rdg. ±0.013 V
Resistance	✓			600.0 Ω, 6.000 kΩ, 60.00 kΩ, 600.0 kΩ, 6.000 MΩ	±0.7% rdg. ±0.5 Ω
Temperature	✓			-40.0°C to 400.0°C	±0.5% rdg. ±3.0°C
Electrostatic capacity	✓			1.000 μF, 10.00 μF, 100.0 μF, 1000 μF	±1.9% rdg. ±0.005 μF
Frequency	✓			9.999 Hz, 99.99 Hz, 999.9 Hz	±0.1% rdg. ±0.003 Hz

Other	
Display refresh rate	5 times/s ²
Operating temperature	-25°C to 65°C, 90% RH or less (non-condensating)
Storage temperature	-30°C to 70°C, 90% RH or less (non-condensating)
Dustproof and waterproof	IP50 ^{3,4}
Power supply	Alkaline battery LR03 x 2
Continuous operating time	48 hours ⁵
Dimensions (W x H x D)	65 x 247 x 35 mm (2.56 x 9.72 x 1.38 in.)
Weight	300 g (10.6 oz.)

Order code **CM4141-50**

Order code **CM4141-90**

Order code **Z3210**

Model CM4141-90 includes Z3210 as a set

*1: Only when DC HIGH VOLTAGE PROBE P2010 is used *2: Excludes electrostatic capacity, frequency, and temperature
 *3: Voltage measurement in a completely dry condition. When jaw closes. *4: While in storage. *5 With backlight and Bluetooth® communications turned off



Model	3280-10F	CM3289	CM3281, CM3291	Basic accuracy	
AC Current	✓	✓	N/A	42.00 A, 420.0 A, 1000 A (guaranteed accuracy range: 4.00A to 1000 A)	±1.5% rdg. ±5 dgt.
AC Voltage	✓	✓	✓	42.00 A, 420.0 A, 2000 A (guaranteed accuracy range: 4.00A to 1999 A)	±1.5% rdg. ±5 dgt.
DC Voltage	✓	✓	✓	4.200 V, 42.00 V, 420.0 V, 600 V	±1.8% rdg. ±7 dgt.
Resistance	✓	✓	✓	420.0 mV, 4.200 V, 42.00 V, 420.0 V, 600 V	±1.0% rdg. ±3 dgt.
				420.0 Ω, 4.200 kΩ, 42.00 kΩ, 420.0 kΩ, 4.200 MΩ, 42.00 MΩ	±2.0% rdg. ±4 dgt.

Other	
Display refresh rate	2.5 times/s
Operating temperature	-25°C to 65°C, 80% RH or less (non-condensating)
Storage temperature	-25°C to 65°C, 80% RH or less (non-condensating)
Dustproof and waterproof	IP40 (EN60529) ^{2,3}
Power supply	Coin type lithium battery CR2032 x 1
Continuous operating time	3280-10F, CM3281: 120 hours CM3289: 70 hours CM3291: 70 hours
Dimensions (W x H x D)	3280-10F: 57 x 175 x 16 mm (2.24 x 6.89 x 0.63 in.) CM3289: 57 x 181 x 16mm (2.24 x 7.13 x 0.63 in.) CM3281, CM3291: 57 x 198 x 16 mm (2.24 x 7.80 x 0.63 in.)
Weight	3280-10F: 100 g (3.5 oz.) CM3289: 100 g (3.5 oz.) CM3281, CM3291: 103 g (3.6 oz.)



3280F, CM3289, CM3291 are compatible with the CT6280 AC Flexible Current Sensor

Φ130mm (5.1 in.), 4200 A AC

Model 3280-70F includes 3280-10F AC Clamp Meter and CT6280 AC Flexible Sensor as a set

Order code **3280-10F**

Order code **3280-70F**

Order code **CM3289**

Order code **CM3291**

Order code **CM3281**

*1: Excludes 3280-10F, 3280-70F
 *2: Excludes CM3289, CM3281, CM3291
 *3: While in storage



Model	CM4001	CM4002	CM4003	Basic accuracy	
AC Current	✓	N/A	N/A	60.00 mA, 600.0 mA, 6.000A, 60.00A, 600.0A (guaranteed accuracy range: 0.60 mA to 600.0A)	±1.5% rdg. ±0.05 mA
	N/A	✓	✓	6.000 mA, 60.00 mA, 600.0 mA, 6.000A, 60.00A, 200.0A (guaranteed accuracy range: 0.060 mA to 200.0A)	±1.0% rdg. ±0.005 mA
Frequency	✓	N/A	N/A	999.9 Hz	±1.5% rdg. ±0.1 Hz
	N/A	✓	✓	999.9 Hz, 2000 Hz	±0.1% rdg. ±0.1 Hz

Other	
Display refresh rate	5 times/s
Operating temperature	-10°C to 65°C (non-condensating)
Storage temperature	CM4001: -10°C to 65°C (non-condensating) CM4002, CM4003: -30°C to 70°C (non-condensating)
Dustproof and waterproof	CM4002, CM4003: IP40 (EN60529)
Power supply	CM4001: LR03 Alkaline battery x 1, 32 hours CM4002, CM4003: LR6 Alkaline battery x 2, 48 hours (LR6, without Z3210)
Continuous operating time	CM4003: AC ADAPTER Z1013 (option)
Dimensions (W x H x D)	CM4001: 37 x 160 x 27 mm (1.46 x 6.30 x 1.06 in.) CM4002, CM4003: 64 x 233 x 36 mm (2.52 x 9.17 x 1.41 in.)
Weight	CM4001: 115 g (4.1 oz.) CM4002, CM4003: 400 g (14.1 oz.)

Includes external output function (CM4003 Only)

Pair with a recorder to capture instantaneous or current waveforms

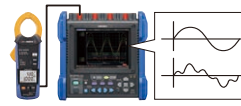

RMS value output (RMS mode)
 DC 600 mV/f.s.
Waveform output (WAVE mode)
 AC 600 mV/f.s.

*Using CONNECTION CABLE L9097 (included accessories)

Order code **CM4001**

Order code **CM4001-90**

Order code **CM4002**

Order code **CM4002-90**

Order code **CM4003**

Order code **CM4003-90**

Order code **Z3210**

Model CM4001-90, CM4002-90, CM4003-90 includes Z3210 as a set



For more details

 Product warranty for 3 years
 Accuracy guaranteed for 1 year

AC CLAMP POWER METER CM3286-50

 $\Phi 46 \text{ mm} = 1.81 \text{ in.}$

CM3286-50

AC 600 A

True RMS

 CAT IV 600 V
 CAT III 1000 V

With Z3210

 Please see www.hioki.com
 for list of supported regions.

**Gennect
Cross**

 WIRELESS ADAPTER
 Z3210 (option)

**Attach to enable Bluetooth®
wireless technology**

 Order code **CM3286-50**

 Order code **CM3286-90**

 Order code **Z3210**

 Model CM3286-90
 includes Z3210 as a set

Included accessories

L9257
C0203

- LR03 Alkaline battery x 2
- Instruction manual

*1: Harmonics can be displayed using dedicated application software (Gennect Cross)
 *2: Voltage measurement in a completely dry condition. When jaw closes.
 *3: While in storage.

Power (Active/reactive/apparent)	Single phase	3.600 kW, 36.00 kW, 360.0 kW Guaranteed accuracy range: 0.005 kW to 360.0 kW Basic accuracy: $\pm 2.0\%$ rdg. ± 7 dgt.
	Balanced three-phase 3-wire	7.200 kW, 72.00 kW, 720.0 kW guaranteed accuracy range: 0.020 kW to 623.5 kW Basic accuracy: $\pm 3.0\%$ rdg. ± 10 dgt.
	Balanced three-phase 4-wire	10.80 kW, 108.0 kW, 1080 kW guaranteed accuracy range: 0.040 kW to 1080 kW Basic accuracy: $\pm 2.0\%$ rdg. ± 3 dgt.
AC Current	6.000 A, 60.00 A, 600.0 A Basic accuracy: $\pm 1.0\%$ rdg. ± 3 dgt.	
AC Voltage	600.0 V Basic accuracy: $\pm 0.7\%$ rdg. ± 3 dgt.	
Power factor	Single-phase, Balanced three-phase 4-wire: [Regeneration] -1.000 to -0.001, [Consumption] 0.000 to 1.000 Balanced three-phase 3-wire: [Regeneration] -0.001, [Consumption] 0.000 to 1.000	
Phase angle	Single-phase, Balanced three-phase 4-wire: [lead] -180.0° to -0.1°, [lag] 0.0° to 179.9° Balanced three-phase 3-wire: [lead] -90.0° to -0.1°, [lag] 0.0° to 90.0°	
Frequency	45.0 Hz to 999.9 Hz	
Simple Active Energy Consumption (single-phase)	99.99 Wh, 999.9 Wh, 9.999 kWh, 99.99 kWh, 999.9 kWh, 9999 kWh	
Harmonic ^{*1} (with Z3210)	Voltage or current harmonic levels up to 30th order, content factor, total harmonic distortion ratio	
Display refresh rate	2 times/s	
Operating temperature	-25°C to 65°C, 80% RH or less (non-condensating)	
Storage temperature	-25°C to 65°C, 80% RH or less (non-condensating)	
Dustproof and waterproof	IP20 ² /IP50 ³	
Power supply	LR03 Alkaline battery x 2	
Continuous operating time	25 hours	
Dimensions (W x H x D)	65 x 241 x 35 mm (2.56 x 9.49 x 1.38 inch)	
Weight	450 g (15.9 oz.)	

Clamp

Insulation

DIMMS

Detectors

Earth

Power quality

Power loggers

Battery

PV

Logger

LAN

Lux

Temperature

Resistance

Options



CM4371-50
CM4373-50
CM4375-50
CM4141-50
CM3286-50

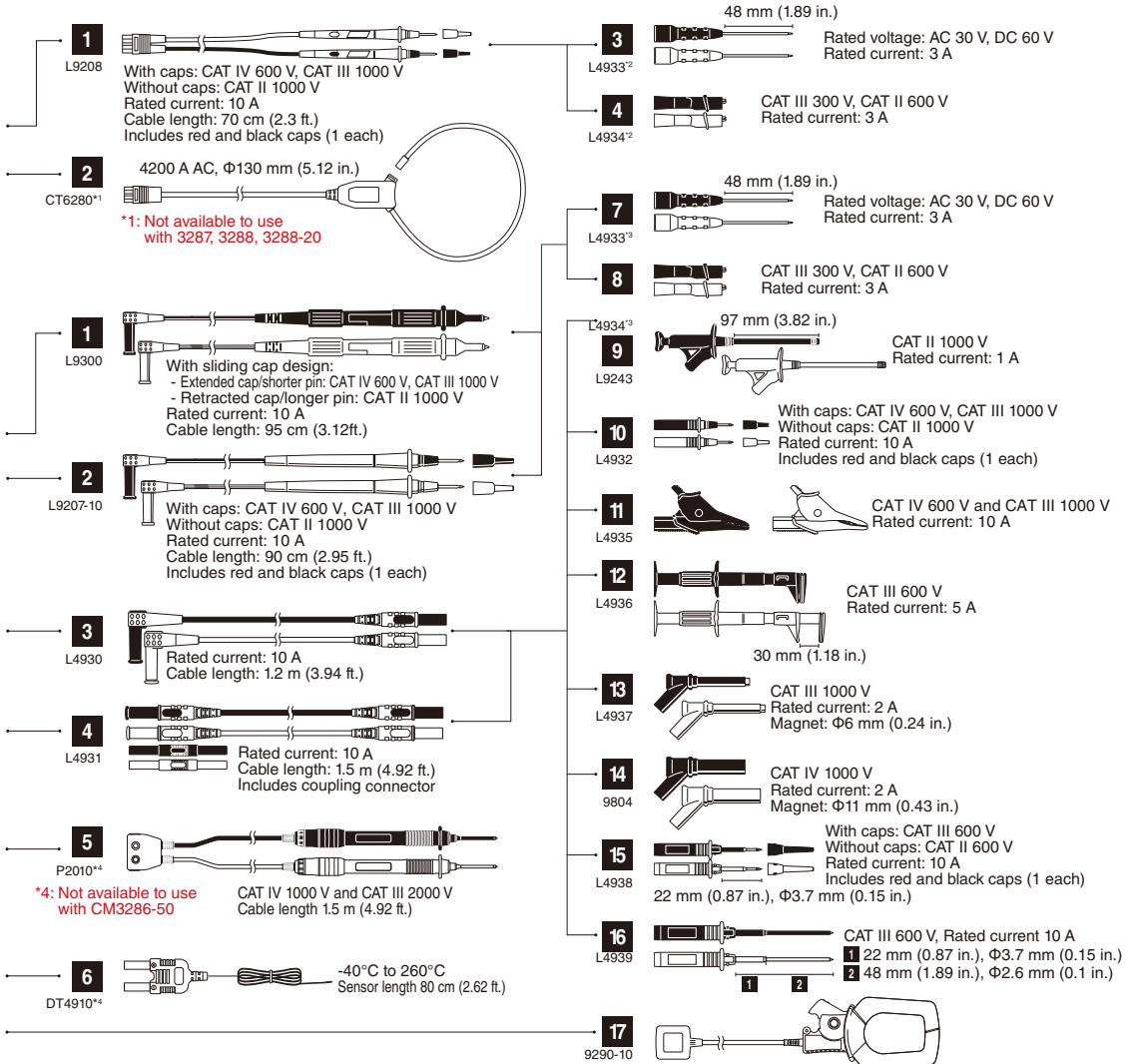

3280-10F, CM3289, CM3291, 3287, 3288, 3288-20

1	TEST LEAD L9208	With caps: CAT IV 600 V, CAT III 1000 V Without caps: CAT II 1000 V Rated current: 10 A
2	AC FLEXIBLE CURRENT SENSOR CT6280	For 3280-10F, CM3289, CM3281, CM3291 AC 4200 A, Φ 130 mm (5.12 in.)
3	CONTACT PIN SET L4933	AC 30 V, DC 60 V, 3 A
4	SMALL ALLIGATOR CLIP SET L4934	CAT III 300 V, CAT II 600 V, 3 A
5	CARRYING CASE 9398	For 3280-10F, CM3289, 3287, 3288, 3288-20
6	CARRYING CASE C0205	Bundled accessory for CT6280
7	TEST LEADS HOLDER 9209	For 3280-10F, CM3289, 3287, 3288, 3288-20



CM4371-50, CM4373-50, CM4375-50, CM4141-50, CM3286-50

1	TEST LEAD L9300	CAT IV 600 V, CAT III 1000 V CAT II 1000 V Rated current: 10 A
2	TEST LEAD L9207-10	With caps: CAT IV 600 V, CAT III 1000 V Without caps: CAT II 1000 V 10 A
3	CONNECTION CABLE SET L4930	10 A
4	EXTENSION CABLE SET L4931	10 A
5	DC HIGH VOLTAGE PROBE P2010	Excluding CM3286-20 CAT IV 1000 V, CAT III 2000 V
6	THERMOCOUPLES (K) DT4910	Excluding CM3286-20
7	CONTACT PIN SET L4933	AC 30 V, DC 60 V, 3 A
8	SMALL ALLIGATOR CLIP SET L4934	CAT III 300 V, CAT II 600 V, 3 A
9	GRABBER CLIP L9243	CAT II 1000 V, 1 A
10	TEST PIN SET L4932	With caps: CAT IV 600 V, CAT III 1000 V Without caps: CAT II 1000 V 10 A
11	ALLIGATOR CLIP SET L4935	CAT IV 600 V, CAT III 1000 V, 10 A
12	BUS BAR CLIP SET L4936	CAT III 600 V, 5 A
13	MAGNETIC ADAPTER SET L4937	CAT III 1000 V, 2 A
14	MAGNETIC ADAPTER SET 9804	CAT IV 1000 V, 2 A
15	TEST PIN SET L4938	With caps: CAT III 600 V Without caps: CAT II 600 V 10 A
16	BREAKER PIN SET L4939	CAT III 600 V, 10 A
17	CLAMP ON ADAPTER 9290-10	For CM3286-50 AC 1000 A, Φ 55 mm, CT ratio 10 : 1
18	CONNECTION CORD L9257	Combination of L4930 and L4935
19	CARRYING CASE C0203	



CM4002, CM4003

1	CONNECTION CABLE L9097	For CM4003
2	CONVERSION ADAPTER 9704	For CM4003
3	AC ADAPTER Z1013	For CM4003
4	CARRYING CASE C0203	

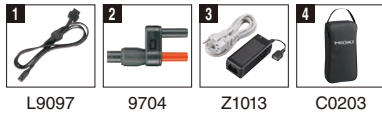

- Clamp
- Insulation
- DIMMS
- Detectors
- Earth
- Power quality
- Power loggers
- Battery
- PV
- Logger
- LAN
- Lux
- Temperature
- Resistance



INSULATION TESTERS

Drop proof

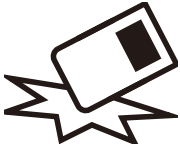

Built tough to withstand a 1-meter drop onto a concrete floor



5 ranges

Rated output voltage (DC)
Effective maximum indicated value

- 50 V , 100 MΩ
- 125 V , 250 MΩ
- 250 V , 500 MΩ
- 500 V , 2000 MΩ
- 1000 V , 4000 MΩ

Manage Measurement Data Using Bluetooth® Communication



WIRELESS ADAPTER Z3210 (option)
Attach to enable Bluetooth® wireless technology



Learn More

Transport to the Excel® file

Location	Circuit no.	Ref. value	Measurement place	Value(MΩ)
Circuit Breaker A	L-A	0.1MD	R-E	101 M Ohm
			S-E	101 M Ohm
			T-E	101 M Ohm
			R-S	66.4 M Ohm
			S-T	99.9 M Ohm
			T-R	99.9 M Ohm
			R-T	99.9 M Ohm
			T-S	99.9 M Ohm

Open an Excel® file and select a cell. The measured value being held on the instrument's display will be transferred to the computer and entered into the selected cell.

Transport to Gennect Cross

Learn More

PDF Reports
CSV Measurement data
JPG Image data

Gennect Cross, a free app designed specifically for use with Hioki measuring instruments, lets you check and manage measurement results and create reports. The software provides a range of functionality that helps manage data in the field, including photographing measurement sites, placing measurement results on photographs, and saving handwritten memos.

Recording measured values on the photograph
Record it at tap point
Display the measurement number for prevent wrong record

Significantly Improve Testing Speed using Test Lead with Remote Switch

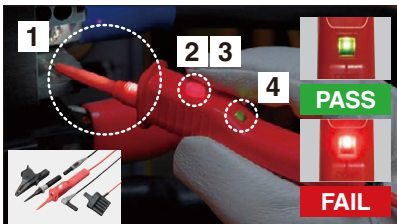

- 1 LED light shines a spotlight on the target
- 2 Red light warns of live voltage detection
- 3 Measurement start switch
- 4 Identify pass/fail decisions with red or green light

TEST LEAD SET WITH REMOTE SWITCH L9788-11 (option)
*Standard with the IR4059 and IR4056-21

Identify PASS/FAIL using Light and Sound



Compare measured values to pre-set reference values to generate a pass or fail decision with the Comparator function.

Convenient for Inspections

- Low resistance measurement^{*1}**
Perform EV and HEV continuity checks as well as resistance measurement of protective conductors in facility electrical equipment as defined by IEC 60364.
- AC/DC voltage measurement**
Automatically detect AC or DC for testing. Use as a tester thanks to DC voltage measurement functionality.
- PV Ω dedicated function^{*2}**
Measurement is not affected even when the PV system is online.
^{*1} Excludes IR4053 ^{*2} IR4053 Only

One-touch Start and Stop

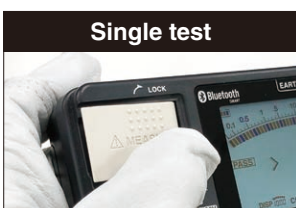

Measurement voltage is applied while MEASURE key is pressed



Lift and lock the MEASURE key to apply a continuous stream of voltage







Prevent Accidental High Voltage Generation



Under [500V], [1000V], or [PVΩ] settings, the RELEASE button will blink. Press to unlock the release of high voltages as an extra safety measure.



Lineup - Digital

Measurement type	Low voltage (less than 1000 V)				High voltage (less than 5000 V)	
	Standard	High-speed	EV	PV		Standard
Model	IR4056-20 IR4056-21	IR4057-50	IR4059	IR4053-10	IR5051	IR5050
Appearance						
Number of ranges	5				5	
Applied voltage (DC) and effective maximum indicated value	50 V, 100 MΩ 125 V, 250 MΩ 250 V, 500 MΩ 500 V, 2000 MΩ 1000 V, 4000 MΩ				250 V, 500 GΩ 500 V, 1.00 TΩ 1000 V, 2.00 TΩ 2500 V, 5.00 TΩ 5000 V, 10.00 TΩ	
PV Ω measurement	N/A		500 V, 2000 MΩ 1000 V, 4000 MΩ		500 V, 100 GΩ 1000 V, 100 GΩ 1500 V, 100 GΩ	N/A
Leakage current measurement	N/A				0.00 nA to 2.00 mA	
DC voltage measurement	600 V		1000 V		2000 V	
AC voltage measurement	600 V				1000 V	
Low resistance measurement	✓		N/A		N/A	
Displaying 1-min. values	N/A	✓	N/A		N/A	
Comparator decision response time	0.8 second ✓	0.3 second ✓	0.8 second ✓ (PV: 4 second)		N/A	
AUTO power save	✓				✓	
Bluetooth® communication	N/A	✓ (with Z3210)		N/A	✓ (with Z3210)	
Resistance gauge	N/A	✓		N/A	✓	
Backlight	✓				✓	
Safety standard category	CAT III 600 V				CAT IV 1000 V CAT III 2000 V	
CE	✓ ¹				✓	
Dustproof and waterproof	IP40 ²				IP40 ^{2,3} , IP65 ⁴	
Drop proof	✓				N/A	
Power supply	LR03 (AAA) alkaline battery × 4 HR6 (AA) NiMH rechargeable battery × 4				LR6 (AA) alkaline battery × 8 HR6 (AA) NiMH rechargeable battery × 8	
Dimensions (W × H × D)	159 × 177 × 53 mm 6.26 × 6.97 × 2.09 in.		160 × 98 × 46 mm 6.30 × 3.86 × 1.81 in.	159 × 177 × 53 mm 6.26 × 6.97 × 2.09 in.	195 × 254 × 89 mm 7.68 × 10 × 3.50 in.	
Weight	600 g (21.2 oz.)	640 g (22.6 oz.)	536 g (18.9 oz.)	600 g (21.2 oz.)	1.7 kg (59.97 oz.)	

¹ IR4056-21 excluded ² Terminals are excluded ³ When the protector is attached ⁴ When stored in attached CARRYING CASE C0212

Lineup - Analog Meters



Product warranty for 3 years
Accuracy guaranteed for 1 year

Measurement parameters	3 3490 Ranges		Applied voltage (DC)	250 V	500 V	1000 V	
			Effective maximum indicated value	100 MΩ		4000 MΩ	
			1st effective measuring range	0.05 MΩ to 50 MΩ		2 MΩ to 1000 MΩ	
			2nd effective measuring range	0.01 MΩ to 0.05 MΩ or less 50 MΩ to 100 MΩ		0.5 MΩ to 2 MΩ 1000 MΩ to 4000 MΩ	
	1 IR4016 -20 Range		Applied voltage (DC)	500 V			
			Effective maximum indicated value	100 MΩ			
			1st effective measuring range	0.1 MΩ to 50 MΩ			
			2nd effective measuring range	0.01 MΩ to 0.1 MΩ or less 50 MΩ or more to 100 MΩ			
	1 IR4017 -20 Range		Applied voltage (DC)	500 V			
			Effective maximum indicated value	1000 MΩ			
			1st effective measuring range	1 MΩ to 500 MΩ			
			2nd effective measuring range	0.5 MΩ to 1 MΩ or less 500 MΩ or more to 1000 MΩ			
1 IR4018 -20 Range		Applied voltage (DC)	1000 V				
		Effective maximum indicated value	2000 MΩ				
		1st effective measuring range	2 MΩ to 1000 MΩ				
		2nd effective measuring range	1 MΩ to 2 MΩ or less 1000 MΩ or more to 2000 MΩ				
Accuracy (insulation)			±2% of scale length (1st effective measuring range) ±2% of scale length (2nd effective measuring range)				
AC Voltage			0 to 600 V				

Other	Operating temperature	0°C to 40°C, 90% RH or less (non-condensating)
	Storage temperature	-10°C to 50°C, 90% RH or less (non-condensating)
	Dustproof and waterproof	IP40 (terminal excluded)
	Drop proof	YES
	Backlight	YES
	Safety standard category	CAT III 600 V
	Standards	EN61010 (Safety), EN61326 (EMC)
	Power supply	LR6 alkaline battery × 4
	Continuous operating time	20 hours
	Dimensions (W × H × D)	3490: 162 × 167 × 52 mm (6.38 × 6.57 × 2.05 in.) IR4016, IR4017, IR4018: 162 × 182 × 57 mm (6.38 × 7.17 × 2.24 in.)
Weight	3490: 840 g (29.6 oz.), IR4016, IR4017, IR4018: 820 g (28.9 oz.)	

Included accessories



L9787

- TEST LEAD L9787 (1.2 m)
- Neck strap
- LR6 alkaline battery × 4
- Instruction manual

Order code	3490
Order code	IR4016-20
Order code	IR4017-20
Order code	IR4018-20

- Clamp
- Insulation
- DIMMS
- Detectors
- Earth
- Power quality
- Power loggers
- Battery
- PV
- Logger
- LAN
- Lux
- Temperature
- Resistance

INSULATION TESTER IR4056-20, IR4056-21



* IR4056-20 only

Product warranty for 3 years
Accuracy guaranteed for 1 year



- Included accessories
- TEST LEAD L9787
- Neck strap
- LR6 alkaline battery x 4
- Instruction manual

IR4056-20



- Included accessories
- TEST LEAD SET WITH REMOTE SWITCH L9788-11
- Neck strap
- LR6 alkaline battery x 4
- Instruction manual

IR4056-21

Not CE marked



Comparator decision response time : 0.8 s

5 ranges

CAT III 600 V



* IR4057-50 only

Product warranty for 3 years
Accuracy guaranteed for 1 year

INSULATION TESTER IR4057-50, IR4059



IR4057-50



IR4059



L4930



L4938



L4935



WIRELESS ADAPTER Z3210 (option)

Attach to enable Bluetooth® wireless technology

With Z3210



Please see www.hioki.com for list of supported regions.



Comparator decision response time : 0.3 s

Digital bar graph

5 ranges

CAT III 600 V

Included accessories

- CONNECTION CABLE L4930
- ALLIGATOR CLIP SET L4935
- TEST PIN SET L4938
- TEST LEAD SET WITH REMOTE SWITCH (RED) L9788-10 (IR4059 only)
- PROTECTOR Z5042 (IR4059 only)
- Neck strap
- LR6 alkaline battery x 4
- Instruction manual



INSULATION TESTER (for Photovoltaic Generation Systems) IR4053-10

Product warranty for 3 years
Accuracy guaranteed for 1 year



- Included accessories
- TEST LEAD L9787
- Neck strap
- LR6 alkaline battery x 4
- Instruction manual

IR4053-10



Comparator decision response time : 0.8 s

Comparator decision response time (PV) : 4 s

5 ranges

CAT III 600 V

Model	IR4056-20	IR4056-21	IR4057-50	IR4059	IR4053	Basic accuracy						
						Applied voltage (DC)	50 V	125 V	250 V	500 V	1000 V	-
Measurement parameters	Insulation resistance	✓	✓	✓	-	Applied voltage (DC)	50 V	125 V	250 V	500 V	1000 V	-
						Effective maximum indicated value (MΩ)	100	250	500	2000	4000	-
						1st effective measuring range (MΩ)	0.200 to 10.00	0.200 to 25.0	0.200 to 50.0	0.200 to 500	0.200 to 1000	±2% rdg. ±2 dgt.
						2nd effective measuring range (MΩ)	10.1 to 100.0	25.1 to 250	50.1 to 500	501 to 2000	1010 to 4000	±5% rdg.
Measurement parameters	PV Ω measurement	N/A	-	✓	-	Applied voltage (DC)	500 V	1000 V	-	-	-	-
						Effective maximum indicated value (MΩ)	2000	4000	-	-	-	
						1st effective measuring range (MΩ)	0.200 to 500	0.200 to 1000	-	-	±4% rdg.	
						2nd effective measuring range (MΩ)	501 to 2000	1010 to 4000	-	-	±8% rdg.	
Measurement parameters	DC Voltage	N/A	✓	N/A	-	4.200 V, 42.00 V, 420.0 V, 1000 V	-	-	-	-	-	±1.3% rdg. ±4 dgt. ¹
						4.200 V, 42.00 V, 420.0 V, 600 V	-	-	-	-	±1.3% rdg. ±4 dgt. ¹	
						420.0 V ² , 600 V	-	-	-	-	±2.3% rdg. ±8 dgt. ¹	
Measurement parameters	AC Voltage	✓	✓	✓	-	420.0 V ² , 600 V	-	-	-	-	-	±2.3% rdg. ±8 dgt. ¹
						Low resistance measurement	✓	N/A	10.00 Ω, 100.0 Ω, 1000 Ω	-	-	-

Operating temperature	IR4056-20, IR4056-21, IR4057-50, IR4059: -25°C to 65°C, 90% RH or less (non-condensating)
	IR4053: 0°C to 50°C, 90% RH or less (non-condensating)
Storage temperature	IR4056-20, IR4056-21, IR4057-50, IR4059: -25°C to 65°C, 90% RH or less (non-condensating)
	IR4053: -10 °C to 50°C, 90% RH or less (non-condensating)
Dustproof and waterproof	IP40 (terminal excluded)
Standards	EN61326 (EMC), EN61557-1/2/4 ³ /10
Power supply	LR6 alkaline battery x 4
Continuous operating time	20 hours
Dimensions (W x H x D)	IR4056-20, IR4056-21, IR4057-50, IR4053-10: 159 x 177 x 53 mm (6.26 x 6.97 x 2.09 in.)
	IR4059: 160 x 98 x 46 mm (6.30 x 3.86 x 1.81 in.)
Weight	IR4056-20, IR4056-21, IR4053: 600 g (21.2 oz.)
	IR4059: 536 (18.9 oz.)
	IR4057-50: 640 g (22.6 oz.)

¹ Ranges in excess of 600 V, 1000 V are outside the accuracy guarantee
² Minimum indicated value: 30.0 V
³ Subclause 4.3 of Part 4 (interchanging of test leads) is not applicable when L9788-10 is used

Order code **IR4056-20**

Order code **IR4056-21**

Order code **IR4057-50**

Order code **IR4057-90**

Order code **IR4059**

Order code **IR4053-10**

Order code **Z3210**

Model IR4057-90 includes Z3210 as a set



HIGH VOLTAGE INSULATION TESTER IR5050, IR5051

Product warranty for 3 years
Accuracy guaranteed for 1 year



IR5050

IR5051
IR5051-90 (include Z3210 as a set)

Standard **For PV systems**

5 ranges

CAT IV 1000 V, CAT III 2000 V

Order code **IR5050**

Order code **IR5051**

Order code **IR5051-90**

Included accessories

- TEST LEAD L9850-01 (red), -02 (black), -03 (blue), 3 m (9.84 ft.)
- ALLIGATOR CLIP L9851-01 (red), -02 (black) , -03 (blue)
- CARRYING CASE C0212
- LR6 alkaline battery x 8
- Instruction manual
- TEST PIN SET L9852 (IR5051 and IR5051-90 only)
- WIRELESS ADAPTER Z3210 (IR5051-90 only)

L9850, L9851

Options

IR4016-20, IR4017-20, IR4018-20, IR4056-20,
IR4056-21, IR4057-50, IR4057-90, IR4053-10,
IR4059, 3490

- 1 TEST LEAD SET WITH REMOTE SWITCH L9788-11
- 2 TEST LEAD WITH REMOTE SWITCH (RED) L9788-10
- 3 TIP PIN L9788-90
- 4 BREAKER PIN L9788-92
- 5 MAGNETIC ADAPTER 9804-01
- 6 MAGNETIC ADAPTER 9804-02
- 7 TEST LEAD L9787
- 8 CONNECTION CABLE SET L4930
- 9 ALLIGATOR CLIP SET L4935
- 10 TEST PIN SET L4938
- 11 BREAKER PIN L9787-91
- 12 WIRELESS ADAPTER Z3210 (for IR4057-50, IR4059)
- 13 PROTECTOR Z5042 (for IR4059)
- 14 CARRYING CASE C0213 (EV MAINTENANCE MANUAL INCLUDED)
- 15 FUSE SET Z5052 (for IR4056, IR4057, and IR4059)



IR5050, IR5051

- 1 TEST LEAD L9850-01 Red, 3 m (9.84 ft.)
- 2 TEST LEAD L9850-02 Black, 3 m (9.84 ft.)
- 3 TEST LEAD L9850-03 Blue, 3 m (9.84 ft.)
- 4 TEST LEAD L9850-11 Red, 10 m (32.81 ft.)
- 5 TEST LEAD L9850-12 Black, 10 m (32.81 ft.)
- 6 TEST LEAD L9850-13 Blue, 10 m (32.81 ft.)
- 7 ALLIGATOR CLIP L9851-01 Red
- 8 ALLIGATOR CLIP L9851-02 Black
- 9 ALLIGATOR CLIP L9851-03 Blue
- 10 TEST PIN SET L9852 Red and black
- 11 CARRYING CASE C0212
- 12 WIRELESS ADAPTER Z3210
- 13 COMMUNICATION PACKAGE DT4900-01 USB

Measurement parameters	Applied voltage (DC) and measurement range	
	Insulation resistance	250 V
Leakage current	500 V	0.00 MΩ to 1.00 TΩ
	1000 V	0.00 MΩ to 2.00 TΩ
	2500 V	0.00 MΩ to 5.00 TΩ
	5000 V	0.00 MΩ to 10.00 TΩ
DC voltage	Rated current	1 mA to 1.2 mA
	Short-circuit current	2 mA or less
AC voltage	Accuracy	±5% rdg. ±5 dgt., ±20% rdg.
	Induced noise removal	3 mA max.
Capacitance	Leakage current	10 nA, 100 nA, 1000 nA, 10 μA, 100 μA, 1 mA
	Guaranteed accuracy range: 1.00 nA to 3.00 mA	Accuracy: ±3% rdg. ±3 dgt.
PV insulation resistance (IR5051 only)	DC voltage	±10 V to ±2000 V
	Accuracy: ±3% rdg. ±3 dgt.	
Other	AC voltage	30 V to 1000 V
	Accuracy: ±3% rdg. ±3 dgt.	
Standards	Capacitance	100 nF, 1000 nF, 10 μF
	Guaranteed accuracy range: 10.0 nF to 25.0 μF	Accuracy: ±10% rdg. ±5 nF
Power supply	PV insulation resistance (IR5051 only)	500 V
	0.00 MΩ to 100 GΩ	
Dimensions (W x H x D)	1000 V	0.00 MΩ to 100 GΩ
	1500 V	0.00 MΩ to 100 GΩ
Weight	Operating temperature and humidity range	-20°C to 40°C, less than 80% RH (no condensation)* ¹
	40°C to 45°C, less than 60% RH (no condensation)* ¹	45°C to 50°C, less than 50% RH (no condensation)* ¹
Storage temperature and humidity range	-25°C to 65°C, less than 80% RH (no condensation)* ¹	
	Dustproof/waterproof	IP40* ¹ , IP65 (CARRYING CASE C0212)
Standards	EN IEC61010 (safety), EN61326 (EMC), IEC61557-1, -2 (insulation resistance tester)	
	Power supply	• LR6 (AA) alkaline battery x 8: • Approx. 5 hours without Z3210 installed • Approx. 4 hours with Z3210 installed and using wireless communication
Continuous operating time	• HR6 (AA) nickel-metal hydride (NiMH) rechargeable battery x 8	
	Dimensions (W x H x D)	195mm (7.68 in.) x 254 mm (10 in.) x 89 mm (3.50 in.)
Weight	1.7 kg (59.97 oz.)	

*1: With protector attached, excluding terminals

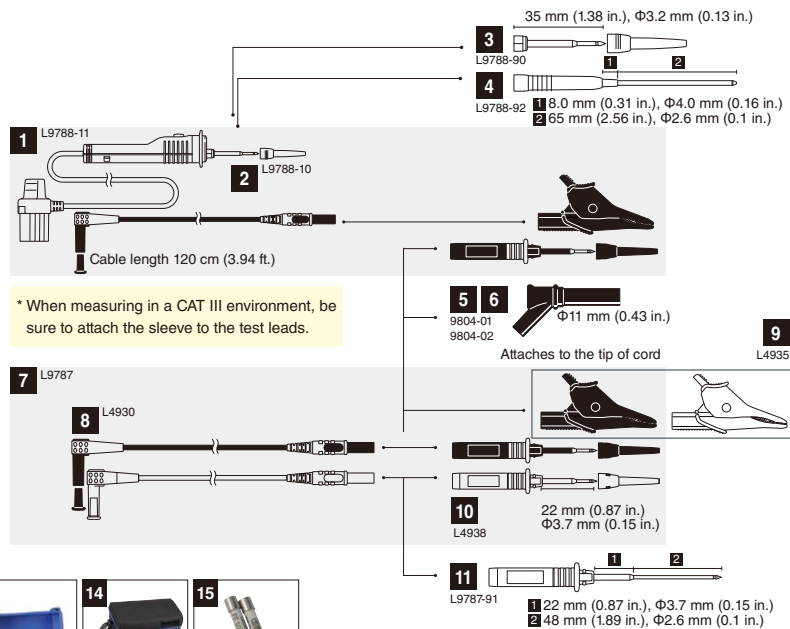



DMM TESTERS

Safely Inspects and Easily Manages Measurement Data for High-Voltage Solar Power Generation

High voltage measurement up to CAT III 2000 V by connecting "P2010"

Supports wireless communication to increase work efficiency



CAT IV 1000 V
CAT III 2000 V



Cooperation with Gennect Cross



DC HIGH VOLTAGE PROBE P2010 (options)



WIRELESS ADAPTER Z3210 (options)



DT4261

Designed and Manufactured in Japan

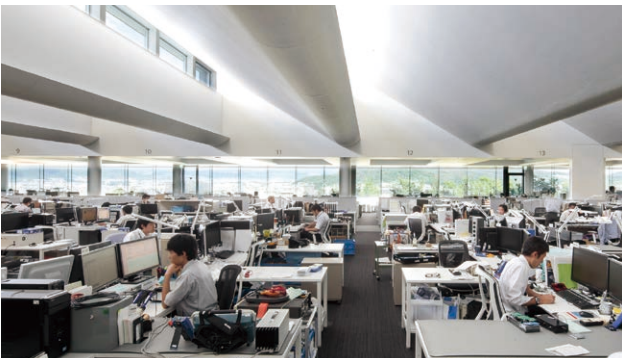

Development, design, and manufacturing processes for almost all Hioki digital multimeters are carried out at our headquarters in Nagano Prefecture.

Withstand a 1-meter Drop onto a Concrete Floor



Products are dropped repeatedly until they are damaged in order to validate their impact performance. Test results are used to make design improvements and enhance durability.

Accurately Measure the Voltage of the Secondary Side of Inverters



Non-distorted current waveforms

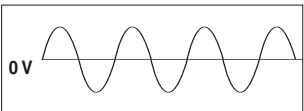

Voltage waveforms with harmonic components



The secondary side of inverters include harmonic components. Waveforms containing harmonics are distorted and difficult to measure with accuracy. By using a low-pass filter to remove harmonic components, accurate measurement values can be obtained.

True RMS Measurement Correctly Captures Distorted Current Waveforms



Non-distorted current waveforms

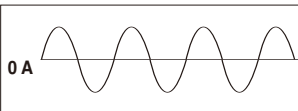



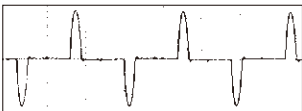



Distorted waveforms due to switching power supplies









A measuring instrument uses one of two rectification methods, "True RMS" or "Mean". Using mean rectification assumes that the signal is based on a sine wave without distortions in order to calculate the value. Distorted waveforms cannot be measured accurately using this method.

- Clamp
- Insulation
- DMMS
- Detectors
- Earth
- Power quality
- Power loggers
- Battery
- PV
- Logger
- LAN
- Lux
- Temperature
- Resistance

Lineup

Measurement type	Electrical work	General use	Solar power, General use	General use	Air conditioning, instrumentation	Electrical work	
Model	High-end models		New standard model	Standard models			
	DT4281	DT4282	DT4261	DT4252	DT4253	DT4255	
Appearance							
AC measurement system	True RMS	True RMS	True RMS	True RMS	True RMS	True RMS	
Display counts	60000	60000	6000	6000	6000	6000	
DCV typical accuracy	±0.025% rdg. ±2 dgt.	±0.025% rdg. ±2 dgt.	±0.15% rdg. ±2 dgt.	±0.2% rdg. ±5 dgt.	±0.3% rdg. ±5 dgt.	±0.3% rdg. ±3 dgt.	
Frequency characteristics	20 Hz to 100 kHz	20 Hz to 100 kHz	40 Hz to 1 kHz	40 Hz to 1 kHz	40 Hz to 1 kHz	40 Hz to 1 kHz	
Measurement parameters	DC voltage (resolution)	1000 V (0.001 mV)	1000 V (0.001 mV)	1000 V, 2000 V ¹ (0.1 mV)	1000 V (0.1 mV)	1000 V (0.1 mV)	1000 V (0.1 mV)
	AC voltage (resolution)	1000 V (0.001 mV)	1000 V (0.001 mV)	1000 V (0.001 V)	1000 V (0.001 V)	1000 V (0.001 V)	1000 V (0.001 V)
	DCV + ACV	1000 V	1000 V	1000 V	N/A	N/A	N/A
	DC current (resolution)	600 mA (0.01 μA)	10 A (0.01 μA)	10 A (0.1 mA)	10 A (0.001 A)	60 mA (0.01 μA)	N/A
	AC current (resolution)	600 mA (0.01 μA)	10 A (0.01 μA)	10 A (0.1 mA)	10 A (0.001 A)	N/A	N/A
	AC current (clamp)	1000 A	N/A	1000 A	N/A	1000 A	1000 A
	Resistance	600 MΩ	600 MΩ	60 MΩ	60 MΩ	60 MΩ	60 MΩ
	Temperature	-40°C to 800°C	-40°C to 800°C	N/A	N/A	-40°C to 400°C	N/A
	Capacitance	100 mF	100 mF	10 mF	10 mF	10 mF	10 mF
	Frequency	500 kHz	500 kHz	99 kHz	99 kHz	99 kHz	99 kHz
	Continuity check	✓	✓	✓	✓	✓	✓
	Diode check	✓	✓	✓	✓	✓	✓
	Conductance	N/A	✓	N/A	N/A	N/A	N/A
	Voltage detection	N/A	N/A	N/A	N/A	N/A	✓
Additional functions	AUTO AC/DCV	N/A	N/A	✓	✓	✓	
	MAX/MIN/AVG	MAX/MIN	MAX/MIN	✓	✓	✓	
	PEAK display	✓	✓	✓	N/A	N/A	
	Relative display	✓	✓	N/A	✓	✓	
	Decibel conversion	✓	✓	N/A	N/A	N/A	
	Percentage conversion display (4-20 mA)	✓	✓	N/A	N/A	✓	
Display	AUTO range	✓	✓	✓	✓	✓	
	Hold display value	AUTO /MANUAL	AUTO /MANUAL	AUTO /MANUAL	AUTO /MANUAL	AUTO /MANUAL	
	Dual display	✓	✓	✓	✓	✓	
	Bar graph display	N/A	N/A	✓	✓	✓	
	Backlight	✓	✓	✓	✓	✓	
Internal memory	✓	✓	N/A	N/A	N/A	N/A	
USB communication ²	✓	✓	✓	✓	✓	✓	
Bluetooth [®] communication	N/A	N/A	✓ (with Z3210)	N/A	N/A	N/A	
Safety	Mis-insertion prevention shutters	✓	✓	✓	N/A	N/A	
	Circuit breaker false trip prevention	N/A	N/A	N/A	N/A	N/A	
	Safety standard category	CAT IV 600 V CAT III 1000 V	CAT IV 600 V CAT III 1000 V	CAT IV 600 V CAT III 1000 V	CAT IV 600 V CAT III 1000 V	CAT IV 600 V CAT III 1000 V	CAT IV 600 V CAT III 1000 V
	CE	✓	✓	✓	✓	✓	✓
	Dustproof and waterproof	IP40	IP40	IP54 ^{*3}	IP40 (when operating) IP42 (while in storage) ^{*3 *4}	IP40 (when operating) IP42 (while in storage) ^{*3 *4}	IP40 (when operating) IP42 (while in storage) ^{*3 *4}
	Drop proof	✓	✓	✓	✓	✓	✓
Auto power off	✓	✓	✓	✓	✓	✓	
Power supply	LR6 ×4 alkaline battery	LR6 ×4 alkaline battery	LR6 ×3 alkaline battery	LR03 ×4 alkaline battery	LR03 ×4 alkaline battery	LR03 ×4 alkaline battery	
Dimensions (W × H × D)	93 × 197 × 53 mm 3.66 × 7.76 × 2.09 in.	93 × 197 × 53 mm 3.66 × 7.76 × 2.09 in.	87 × 185 × 47 mm 3.43 × 7.28 × 1.85 in.	84 × 174 × 52 mm 3.31 × 6.85 × 2.05 in.	84 × 174 × 52 mm 3.31 × 6.85 × 2.05 in.	84 × 174 × 52 mm 3.31 × 6.85 × 2.05 in.	
Weight	650 g, 22.9 oz.	650 g, 22.9 oz.	480 g, 16.9 oz.	390 g, 13.8 oz.	390 g, 13.8 oz.	390 g, 13.8 oz.	

*1: 2000 V is supported only when using the optional DC HIGH VOLTAGE PROBE P2010 *2: Requires optional COMMUNICATION PACKAGE (USB) DT4900-01 *3: Do not use in wet conditions.
*4: Excludes measuring terminals

Measurement type	General use	Electrical work	General use	Electrical work	Electrical work	Electrical work	
Model	Standard models	Pocket models		3030-10	3244-60	3246-60	
	DT4256	DT4223	DT4224				
Appearance							
AC measurement system	True RMS	True RMS	True RMS	N/A	MEAN Value	MEAN Value	
Display count	6000	6000	6000	N/A	4199	4199	
DCV typical accuracy	±0.3% rdg. ±3 dgt.	±0.5% rdg. ±5 dgt.	±0.5% rdg. ±5 dgt.	f.s. reading ±2.5%	±0.7% rdg. ±4 dgt.	±1.3% rdg. ±4 dgt.	
Frequency characteristics	40 Hz to 1 kHz	40 Hz to 1 kHz	40 Hz to 1 kHz	N/A	50 Hz to 500 Hz	50 Hz to 500 Hz	
Measurement parameters	DC voltage (resolution)	1000 V (0.1 mV)	600 V (0.1 mV)	600 V (0.1 mV)	600 V	500 V (0.1 mV)	600 V
	AC voltage (resolution)	1000 V (0.001 V)	600 V (0.001 V)	600 V (0.001 V)	600 V	500 V (0.001 V)	600 V
	DCV + ACV	N/A	N/A	N/A	N/A	N/A	N/A
	DC current (resolution)	10 A (0.01 mA)	N/A	N/A	300 mA	N/A	N/A
	AC current (resolution)	10 A (0.1 mA)	N/A	N/A	N/A	N/A	N/A
	AC current (clamp)	1000 A	N/A	N/A	N/A	N/A	N/A
	Resistance	60 MΩ	60 MΩ	60 MΩ	3 kΩ	42 MΩ	42 MΩ
	Temperature	N/A	N/A	N/A	150°C	N/A	N/A
	Capacitance	10 mF	N/A	10 mF	N/A	N/A	N/A
	Frequency	99 kHz	9.9 kHz	9.9 kHz	N/A	N/A	N/A
	Continuity check	✓	✓	✓	N/A	✓	✓
	Diode check	✓	N/A	✓	N/A	N/A	✓
	Conductance	N/A	N/A	N/A	N/A	N/A	N/A
Voltage detection	✓	✓	N/A	N/A	N/A	N/A	
Additional functions	AUTO AC/DCV	✓	✓	N/A	N/A	N/A	
	MAX/MIN/AVG	✓	N/A	N/A	N/A	N/A	
	PEAK display	N/A	N/A	N/A	N/A	N/A	
	Relative display	✓	✓	✓	N/A	N/A	
	Decibel conversion	N/A	N/A	N/A	N/A	N/A	
	Percentage conversion display (4-20 mA)	N/A	N/A	N/A	N/A	N/A	
Display	AUTO range	✓	✓	✓	N/A	✓	
	Hold display value	AUTO /MANUAL	AUTO /MANUAL	AUTO /MANUAL	N/A	N/A	
	Dual display	✓	N/A	N/A	N/A	N/A	
	Bar graph display	✓	✓	✓	N/A	N/A	
	Backlight	✓	✓	✓	N/A	N/A	
Internal memory	N/A	N/A	N/A	N/A	N/A	N/A	
USB communication ²	✓	N/A	N/A	N/A	N/A	N/A	
Bluetooth [®] communication	N/A	N/A	N/A	N/A	N/A	N/A	
Safety	Mis-insertion prevention shutters	N/A	N/A	N/A	N/A	N/A	
	Circuit breaker false trip prevention	N/A	✓	✓	N/A	N/A	
	Safety standard category	CAT IV 600 V CAT III 1000 V	CAT IV 300 V CAT III 600 V	CAT IV 300 V CAT III 600 V	CAT III 600 V	CAT III 300 V	CAT IV 300 V CAT III 600 V
	CE	✓	✓	✓	N/A	N/A	N/A
	Dustproof and waterproof	IP40 (when operating) IP42 (while in storage) *3 *4	IP40 (when operating) IP42 (while in storage) *3 *4	IP40 (when operating) IP42 (while in storage) *3 *4	N/A	N/A	N/A
	Drop proof	✓	✓	✓	✓	N/A	N/A
Auto power off	✓	✓	✓	N/A	✓	✓	
Power supply	LR03 × 4 alkaline battery	LR03 × 1 alkaline battery	LR03 × 1 alkaline battery	R6P × 2 manganese battery	CR2032 × 1 coin type battery	CR2032 × 1 coin type battery	
Dimensions (W × H × D)	84 × 174 × 52 mm 3.31 × 6.85 × 2.05 in.	72 × 149 × 38 mm 2.83 × 5.87 × 1.50 in.	72 × 149 × 38 mm 2.83 × 5.87 × 1.50 in.	95 × 141 × 39 mm 3.74 × 5.55 × 1.54 in.	55 × 109 × 9.5 mm 2.17 × 4.29 × 0.37 in.	30 × 182 × 26.5 mm 1.18 × 7.17 × 1.04 in.	
Weight	390 g, 13.8 oz.	190 g, 6.7 oz.	190 g, 6.7 oz.	280 g, 9.9 oz.	60 g, 2.1 oz.	80 g, 2.8 oz.	

Clamp

Insulation

DIMMS

Detectors

Earth

Power quality

Power loggers

Battery

PV

Logger

LAN

Lux

Temperature

Resistance

Product warranty for 3 years
Accuracy guaranteed for 1 year



DIGITAL MULTIMETER DT4281, DT4282



DT4281

DT4282

Electrical work



General use



High-end models

60000 Counts

DCV typical accuracy: $\pm 0.025\%$ rdg. ± 2 dgt.

CAT IV 600 V, CAT III 1000 V

Premium DMMs Deliver
High Precision and
Full Array of Features

Extensive additional functionality

It is equipped with additional functions for more advanced measurements. It has a PEAK value display, useful for measuring ripple voltage in DC power supply systems, and a 4-20 mA and 0-20 mA conversion display, useful for measuring instrumentation signals.

- Display of maximum/minimum values
- Display of PEAK value
- Relative display
- Percent conversion 4-20 mA

Product warranty for 3 years
Accuracy guaranteed for 1 year



DIGITAL MULTIMETER DT4261



DT4261

General use



New standard model

6000 Counts

DCV typical accuracy: $\pm 0.15\%$ rdg. ± 2 dgt.

CAT IV 600 V, CAT III 1000 V

With P210 CAT IV 1000 V, CAT III 2000 V

Safely inspects for high-voltage
solar power generation

Safety and convenience



measurable up to
CAT III 2000 V.

DC HIGH VOLTAGE PROBE P210 (options)



Bluetooth[®]
communication is
available

WIRELESS ADAPTER Z3210 (options)



DIGITAL MULTIMETER DT4252, DT4253, DT4255, DT4256

Product warranty for 3 years
Accuracy guaranteed for 1 year



DT4252

DT4253

DT4255

DT4256

General use



Air conditioning, instrumentation



Electrical work



General use



Standard models

6000 Counts

DCV typical accuracy: $\pm 0.3\%$ rdg. ± 5 dgt.

CAT IV 600 V, CAT III 1000 V

Choose from 4 Models to Fit Your Application

Equipped with specialized functions
catering to your needs

Air conditioning, instrumentation

- Measure low currents with 60 μ A range
- Test temperature
- 4 to 20 mA % display

Electrical work

- Prevent short-circuit accidents with a fast-blow fuse and current-limiting resistor



DIGITAL MULTIMETER DT4223, DT4224

Product warranty for 3 years
Accuracy guaranteed for 1 year



DT4223

DT4224

Electrical work



General use



Pocket models

6000 Counts

DCV typical accuracy: $\pm 0.5\%$ rdg. ± 5 dgt.

CAT IV 300 V, CAT III 600 V

Compact and Convenient

Circuit breaker false trip prevention



Eliminate accidents such as tripped earth leakage breakers or flash arcs even when mistakenly inputting voltage while in resistance measurement mode



Model	DT4281	DT4282	Basic accuracy	Basic accuracy
DC voltage	✓	✓	60.000 mV, 600.00 mV, 6.0000 V, 60.000 V, 600.00 V, 1000.0 V	±0.025% rdg. ±2 dgt.
AC voltage	✓	✓	60.000 mV, 600.00 mV, 6.0000 V, 60.000 V, 600.00 V, 1000.0 V	±0.2% rdg. ±25 dgt.
DCV + ACV	✓	✓	6.0000 V, 60.000 V, 600.00 V, 1000.0 V	±0.3% rdg. ±30 dgt.
DC current	✓	N/A	600.00 µA, 6000.0 µA, 60.000 mA, 600.00 mA	±0.05% rdg. ±5 dgt.
AC current	N/A	✓	600.00 µA, 6000.0 µA, 60.000 mA, 600.00 mA, 6.0000 A, 10.000 A	±0.05% rdg. ±5 dgt.
	✓	N/A	600.00 µA, 6000.0 µA, 60.000 mA, 600.00 mA	±0.6% rdg. ±5 dgt.
AC current (clamp)	N/A	✓	600.00 µA, 6000.0 µA, 60.000 mA, 600.00 mA, 6.0000 A, 10.000 A	±0.6% rdg. ±3 dgt.
AC current (clamp)	✓	N/A	10.00 A, 20.00 A, 50.00 A, 100.0 A, 200.0 A, 500.0 A, 1000 A	±0.6% rdg. ±2 dgt.
Resistance	✓	✓	60.000 Ω, 600.00 Ω, 6.0000 kΩ, 60.000 kΩ, 600.00 kΩ, 6.0000 MΩ, 60.00 MΩ, 600.0 MΩ	±0.03% rdg. ±2 dgt.
Temperature	✓	✓	-40.0°C to 800.0°C	±0.5% rdg. ±3°C
Capacitance	✓	✓	1.000 nF, 10.00 nF, 100.0 nF, 1.000 µF, 10.00 µF, 100.0 µF, 1.000 mF, 10.00 mF, 100.0 mF	±1% rdg. ±5 dgt.
Frequency	✓	✓	99.999 Hz, 999.99 Hz, 9.9999 kHz, 99.999 kHz, 500.00 kHz	±0.005% rdg. ±3 dgt.
Continuity check	✓	✓	(Short detection) 20/50/100/500 Ω or less, (open detection) 220/250/300/600 Ω or more	-
Diode check	✓	✓	0.15/0.5/1.0/1.5/2.0/2.5/3.0 V (continuous buzzer sound, flashing red light)	-
Conductance	N/A	✓	600.00 nS	-

Other	
Operating temperature	-15°C to 55°C (non-condensating)
Storage temperature	-30°C to 60°C (non-condensating)
Dustproof and waterproof	IP40
Standards	EN61010 (Safety), EN61326 (EMC)
Power supply	LR6 alkaline battery x4
Continuous operating time	100 hours (backlight OFF)
Dimensions (W x H x D)	93 x 197 x 53 mm (3.66 x 7.76 x 2.09 in.)
Weight	650 g (22.9 oz.)

Included accessories



L9300

- L9300
- LR6 alkaline battery x 4
- Instruction manual

Order code **DT4281**

Order code **DT4282**



Model	DT4252	DT4253	DT4255	DT4256	DT4261	Basic accuracy	
DC voltage	N/A	✓	✓	✓	N/A	600.0 mV, 6.000 V, 60.00 V, 600.0 V, 1000 V	±0.3% rdg. ±5 dgt.
	✓	N/A	N/A	N/A	N/A	600.0 mV, 6.000 V, 60.00 V, 600.0 V, 600.0V, 1000 V	±0.2% rdg. ±5 dgt.
AC voltage	✓	✓	✓	✓	✓	6.000 V, 60.00 V, 600.0 V, 1000 V	±0.15% rdg. ±2 dgt.
DCV + ACV	N/A	N/A	N/A	N/A	✓	6.000 V, 60.00 V, 600.0 V, 1000 V	±0.9% rdg. ±3 dgt.
DC current	N/A	✓	N/A	N/A	N/A	60.00 µA, 600.0 µA, 6.000 mA, 60.00 mA	±1.0% rdg. ±13 dgt.
	N/A	N/A	N/A	✓	N/A	60.00 mA, 600.0 mA, 6.000 A, 10.00 A	±0.8% rdg. ±5 dgt.
	✓	N/A	N/A	N/A	N/A	60.00 mA, 6.000 A, 10.00 A	±0.9% rdg. ±3 dgt.
AC current	N/A	N/A	N/A	✓	✓	6.000 A, 10.00 A	±0.9% rdg. ±5 dgt.
	✓	N/A	N/A	N/A	N/A	600.0 mA, 6.000 A, 10.00 A	±1.4% rdg. ±3 dgt.
AC current (clamp)	N/A	✓	✓	✓	✓	10.00 A, 20.00 A, 50.00 A, 100.0 A, 200.0 A, 500.0 A, 1000 A	±1.4% rdg. ±3 dgt.
Resistance	✓	✓	✓	✓	✓	600.0 Ω, 6.000 kΩ, 60.00 kΩ, 600.0 kΩ, 6.000 MΩ, 60.00 MΩ	±0.9% rdg. ±3 dgt.
Temperature	N/A	✓	N/A	N/A	N/A	-40.0°C to 400.0°C	±0.7% rdg. ±5 dgt.
Capacitance	✓	✓	✓	✓	✓	1.000 µF, 10.00 µF, 100.0 µF, 1.000 mF, 10.00 mF	±0.5% rdg. ±2°C
Frequency	✓	✓	✓	✓	✓	99.99 Hz, 999.9 Hz, 9.999 kHz, 99.99 kHz	±1.9% rdg. ±5 dgt.
Continuity check	✓	✓	✓	✓	✓	(Short detection) 25 Ω or less, (open detection) 245 Ω or more	±0.1% rdg. ±1 dgt.
Diode check	✓	✓	✓	✓	✓	0.15 V to 1.5 V (continuous buzzer sound, flashing red light)	-
Voltage detection	N/A	N/A	✓	✓	N/A	(Detection voltage range) 40 V AC to 600 V AC, (Detection frequency range) 50/60 Hz	-

Other	
Operating temperature	DT4255, DT4256, DT4261: -25°C to 65°C (non-condensating) DT4252, DT4253: -10°C to 50°C (non-condensating)
Storage temperature	DT4255, DT4256, DT4261: -30°C to 70°C (non-condensating) DT4252, 53: -30°C to 60°C (non-condensating)
Dustproof and waterproof	DT4252, DT4253, DT4255, DT4256: IP40 (when operating) DT4261: IP54 ³ DT4251: IP54 ³
Standards	EN61010 (Safety), EN61326 (EMC)
Power supply	DT4252, DT4253, DT4255, DT4256: LR03 alkaline battery x 4
Continuous operating time	DT4261: LR6 alkaline battery x 3 130 hours (backlight OFF)
Dimensions (W x H x D)	DT4252, DT4253, DT4255, DT4256: 84 x 174 x 52 mm (3.31 x 6.85 x 2.05 in.) DT4261: 87 x 185 x 47 mm (3.43 x 7.28 x 1.85 in.)
Weight	DT4252, DT4253, DT4255, DT4256: 390 g (13.8 oz.) DT4261: 480 g (16.9 oz.)

Included accessories



L9300

- Included with DT4252, DT4253, DT4255, DT4256**
- L9300
 - alkaline battery (LR03) x 4
 - Instruction manual

Order code **DT4252**

Order code **DT4253**

Order code **DT4255**

Order code **DT4256**

Order code **DT4261**

Order code **DT4261-90**

Order code **Z3210**

Model DT4261-90 includes Z3210 as a set

*1: DT4261 Only *2: Only when using the optional DC HIGH VOLTAGE PROBE P2010
*3: Do not use in wet conditions *4: Excludes measuring terminals



Model	DT4223	DT4224	Basic accuracy
DC voltage	✓	✓	600.0 mV, 6.000 V, 60.00 V, 600.0 V
AC voltage	✓	✓	6.000 V, 60.00 V, 600.0 V
Resistance	✓	✓	600.0 Ω, 6.000 kΩ, 60.00 kΩ, 600.0 kΩ, 6.000 MΩ, 60.00 MΩ
Capacitance	N/A	✓	1.000 µF, 10.00 µF, 100.0 µF, 1.000 mF, 10.00 mF
Frequency	✓	✓	99.99 Hz, 999.9 Hz, 9.999 kHz
Continuity check	✓	✓	(Short detection) 25 Ω or less, (open detection) 245 Ω or more
Diode check	N/A	✓	0.15 V to 1.5 V (continuous buzzer sound, flashing red light)
Voltage detection	✓	N/A	(Detection voltage range) 80 V AC to 600 V AC, (Detection frequency range) 50/60 Hz

Other	
Operating temperature	-10°C to 65°C (non-condensating)
Storage temperature	-30°C to 70°C (non-condensating)
Dustproof and waterproof	IP40 (when operating), IP42 (while in storage) *1 *2
Standards	EN61010 (Safety), EN61326 (EMC)
Power supply	LR03 alkaline battery x 1
Continuous operating time	40 hours (backlight OFF)
Dimensions (W x H x D)	72 x 149 x 38 mm (2.83 x 5.87 x 1.50 in.)
Weight	190 g (6.7 oz.)

Included accessories



DT4911

- DT4911
- LR03 alkaline battery x 1
- Instruction manual

Order code **DT4223**

Order code **DT4224**

*1: Do not use in wet conditions *2: Excludes measuring terminals

Clamp
Insulation
DMMs
Detectors
Earth
Power quality
Power loggers
Battery
PV
Logger
LAN
Lux
Temperature
Resistance

HITESTER 3030-10

Product warranty for 3 years
Accuracy guaranteed for 1 year



CAT III 600 V

CARRYING CASE 9390



Order code **3030-10**

Included accessories



- TEST LEAD L9207-30
- CARRYING CASE 9390
- R6P manganese battery x2
- Spare fuse
- Instruction manual

L9207-30

Options

- CONTACT PIN SET L4933
- SMALL ALLIGATOR CLIP SET L4934
- HIGH VOLTAGE PROBE 9017
- FUSE SET Z5051

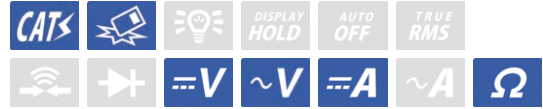

Measurement parameters	DC Voltage	0.3 V, 3 V, 12 V, 30 V, 120 V, 300 V, 600 V Accuracy: $\pm 2.5\%$ of f.s. reading
AC Voltage	12 V, 30 V, 120 V, 300 V, 600 V Accuracy: $\pm 2.5\%$ of f.s. reading, (12V: $\pm 4\%$)	
DC Current	60 μ A, 30 mA, 300 mA Accuracy: $\pm 3\%$ of f.s. reading	
Resistance	0 to 3k Ω : R \times 1, R \times 10, R \times 100, R \times 1k Accuracy: $\pm 3\%$ of scale length	
Battery check	0.9 to 1.8 V Accuracy: $\pm 6\%$ of f.s. reading	
Operating temperature	0°C to 40°C (non-condensating)	
Storage temperature	-10°C to 50°C (non-condensating)	
Power supply	R6P manganese battery x2	
Dimensions (W x H x D)	95 x 141 x 39 mm (3.74 x 5.55 x 1.54 in.)	
Weight	280 g (9.9 oz.)	

CARD HITESTER 3244-60

Product warranty for 3 years
Accuracy guaranteed for 1 year



Cord length
46cm (1.51 ft.)

CAT III 300V, CAT II 600V

CARRYING CASE
C0204



Order code **3244-60**

Included accessories

- CARRYING CASE C0204
- Sleeves (red, black @ 1 each)
- CR2032 coin type battery x1
- Instruction manual



Measurement parameters	DC Voltage	420.0 mV, 4.200 V, 42.00 V, 420.0 V, 500 V Accuracy: $\pm 0.7\%$ rdg. ± 4 dgt.
AC Voltage	4.200 V, 42.00 V, 420.0 V, 500 V Accuracy: $\pm 2.3\%$ rdg. ± 8 dgt.	
Resistance	420.0 Ω , 4.200 k Ω , 42.00 k Ω , 420.0 k Ω , 4.200 M Ω , 42.00 M Ω Accuracy: $\pm 2.0\%$ rdg. ± 4 dgt.	
Continuity check	Detection level: 50 Ω ± 40 Ω or less	
Operating temperature	0°C to 40°C (non-condensating)	
Storage temperature	-20°C to 60°C (non-condensating)	
Power supply	CR2032 coin type battery x1	
Dimensions (W x H x D)	55 x 109 x 9.5 mm (2.17 x 4.29 x 0.37 in.)	
Weight	60 g (2.1 oz.)	

PENCIL HITESTER 3246-60

Product warranty for 3 years
Accuracy guaranteed for 1 year



Cord length
80 cm (2.62 ft.)

CAT IV 300 V, CAT III 600 V

Test lead fits neatly
into back of instrument

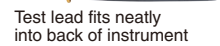

Included accessories

- Sleeves (red, black @ 1 each)
- CR2032 coin type battery x1
- Instruction manual

Order code **3246-60**



Measurement parameters	DC Voltage	420.0 mV, 4.200 V, 42.00 V, 420.0 V, 600 V Accuracy: $\pm 1.3\%$ rdg. ± 4 dgt.
AC Voltage	4.200 V, 42.00 V, 420.0 V, 600 V Accuracy: $\pm 2.3\%$ rdg. ± 8 dgt.	
Resistance	420.0 Ω , 4.200 k Ω , 42.00 k Ω , 420.0 k Ω , 4.200 M Ω , 42.00 M Ω Accuracy: $\pm 2.0\%$ rdg. ± 4 dgt.	
Continuity check	Detection level: 50 Ω ± 40 Ω or less	
Diode check	Judges the right direction only, Open terminal voltage 3.4 V or less	
Operating temperature	0°C to 40°C (non-condensating)	
Storage temperature	-20°C to 60°C (non-condensating)	
Power supply	CR2032 coin type battery x1	
Dimensions (W x H x D)	30 x 182 x 26.5 mm (1.18 x 7.17 x 1.04 in.)	
Weight	80 g (2.8 oz.)	

Options

DT4223, DT4224, DT4252, DT4253, DT4255, DT4256, DT4261, DT4281, DT4282	
1	TEST LEAD DT4911 With caps: CAT IV 600 V, CAT III 1000 V Without caps: CAT II 1000 V Rated current: 10 A
2	TEST LEAD L9300 CAT IV 600 V, CAT III 1000 V CAT II 1000 V 10 A
3	TEST LEAD L9207-10 With caps: CAT IV 600 V, CAT III 1000 V Without caps: CAT II 1000 V 10 A
4	DC HIGH VOLTAGE PROBE P2010 For DT4261 CAT IV 1000 V, CAT III 2000 V
5	CONNECTION CABLE L4930 10 A
6	EXTENSION CABLE SET L4931 10 A
7	THERMOCOUPLES (K) DT4910
8	CONVERSION ADAPTER 9704
9	AC CLAMP ON PROBE 9010-50 ² 500 A AC, Φ 46mm, Frequency characteristics: 40 Hz to 1 kHz
10	AC CLAMP ON PROBE 9018-50 ² 500 A AC, Φ 46mm, Frequency characteristics: 40 Hz to 3 kHz
11	AC CLAMP ON PROBE 9132-50 ² 1000 A AC, Φ 55mm, Frequency characteristics: 40 Hz to 1 kHz
12	CONTACT PIN SET L4933 AC 30 V, DC 60 V, 3 A
13	SMALL ALLIGATOR CLIP SET L4934 CAT III 300 V, CAT II 600 V, 3 A
14	ALLIGATOR CLIP SET L4935 CAT IV 600 V, CAT III 1000 V, 10 A
15	GRABBER CLIP L9243 CAT II 1000 V, 1 A
16	BUS BAR CLIP SET L4936 CAT III 600 V, 5 A
17	MAGNETIC ADAPTER SET L4937 CAT III 1000 V, 2 A
18	TEST PIN SET L4932 With caps: CAT IV 600 V, CAT III 1000 V Without caps: CAT II 1000 V 10 A
19	TEST PIN SET L4938 With caps: CAT III 600 V Without caps: CAT II 600 V 10 A
20	BREAKER PIN L4939 CAT III 600 V, 10 A
21	COMMUNICATION PACKAGE (USB) DT4900-01 For DT4252, DT4253, DT4255, DT4256, DT4261, DT4281, DT4282 Windows 11/10
22	MAGNETIC STRAP Z5004 For DT4223, DT4224, DT4252, DT4253, DT4255, DT4256, DT4261
23	MAGNETIC STRAP Z5020 Extra strength
24	CARRYING CASE C0200 For DT4223, DT4224
25	CARRYING CASE C0201 For DT4252, DT4253, DT4255, DT4256

26	CARRYING CASE C0202 For DT4252, DT4253, DT4255, DT4256, DT4261, DT4281, DT4282
27	CARRYING CASE C0207
28	FUSE SET Z5053 DT4252, DT4256, DT4261, DT4282
29	FUSE SET Z5054 DT4281, DT4282, DT4255
30	FUSE SET Z5055 DT4253

² Adapter Model 9704 is required to connect AC CLAMP ON PROBES 9010-50, 9018-50 and 9132-50 to the DT4281, DT4253, DT4255, DT4256 or DT4261

- Clamp
- Insulation
- DMMS
- Detectors
- Earth
- Power quality
- Power loggers
- Battery
- PV
- Logger
- LAN
- Lux
- Temperature
- Resistance

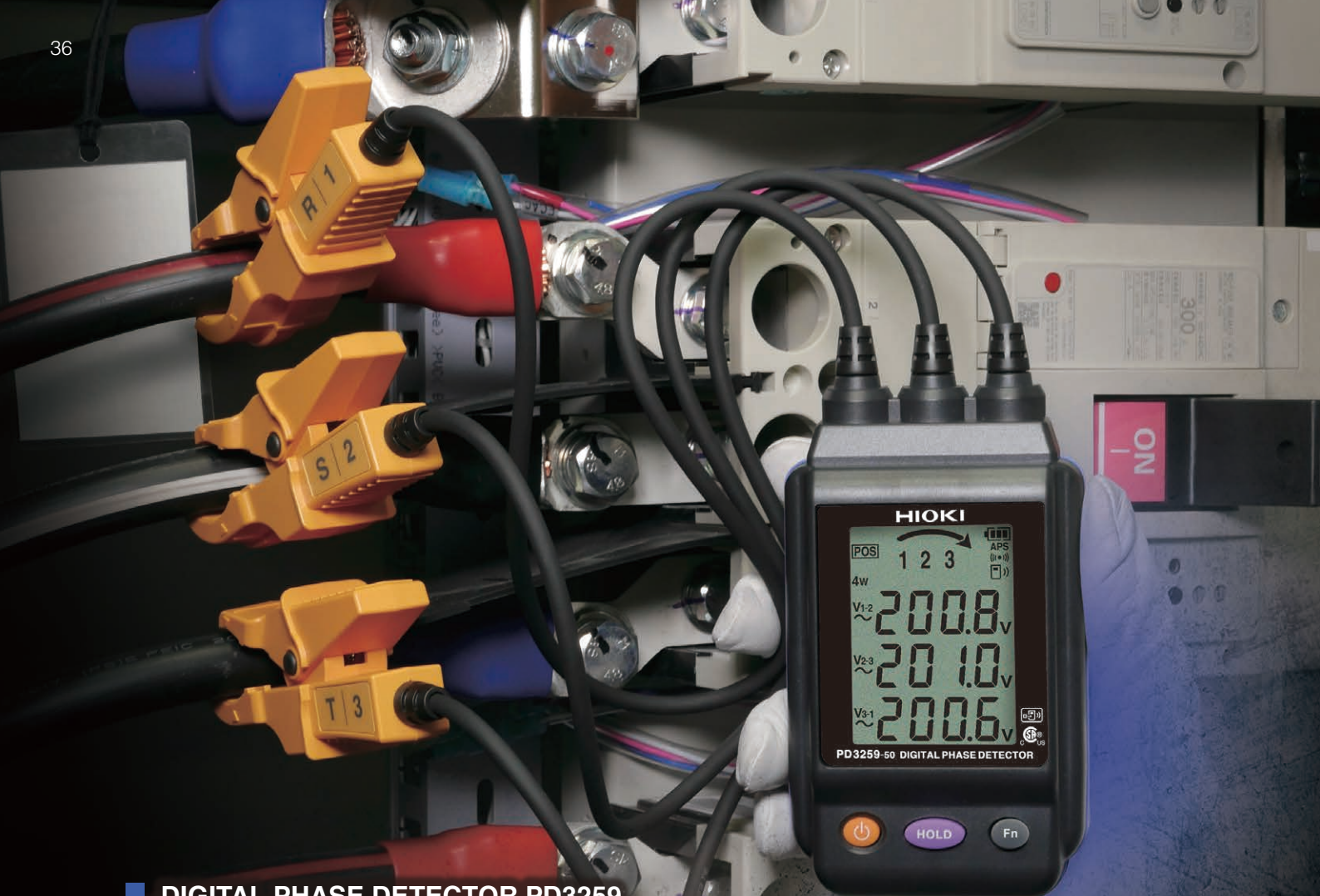

DIGITAL PHASE DETECTOR PD3259

**Just Clip the Probes onto Covered Cables,
and Your 3-phase Power Line Inspection is Complete**

phase
sequence

3-phase
voltage

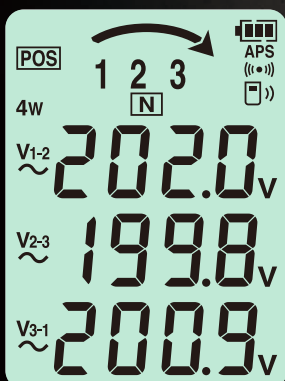

Positive phase sequence display

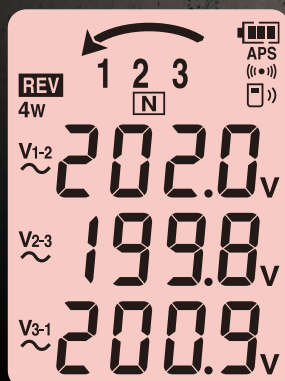

Negative phase sequence display



Display phase sequence, 3-phase voltage
Use as-is in work certification photos

PHASE DETECTORS VOLTAGE DETECTORS

DIGITAL PHASE DETECTOR PD3259-50



Product warranty for 3 years
Accuracy guaranteed for 1 year

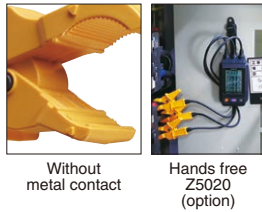

With Z3210
Attach to enable Bluetooth® wireless technology

WIRELESS ADAPTER Z3210 (option)

Bluetooth
Please see www.hioki.com for list of supported regions.

Gennect Cross



CAT IV 600 V

Soil, residue, or moisture on the insulated wires may result in lower voltage and power values than their true values. Use a dry cloth to remove before measuring.

Measurement parameters	Detection functions	Phase detection, open phase, prediction of ground phase (three-phase line)
	Three-phase AC voltage (line-to-line voltage and voltage to ground)	90.0 V to 520.0 V AC (three-phase line) accuracy: ±2.0% rdg. ±8 dgt.
	Frequency	45 Hz to 66 Hz Accuracy: ±0.5% rdg. ±1 dgt.
	Measurement targets	Covered cables, metal portions*1 Finished outer diameter 6 to 30 mm (0.24 to 1.18 in.)
Other	Operating temperature	-25°C to 65°C, 80% RH or less (non-condensating)
	Storage temperature	-25°C to 65°C, 80% RH or less (non-condensating)
	Dustproof and waterproof	IP54 (device body only)
	Standards	EN61010 (Safety), EN61326 Class A (EMC)
	Power supply	LR6 alkaline battery ×4
	Continuous operating time	5 hours (without Z3210)
	Dimensions (W × H × D)	84 × 146 × 46 mm (3.31 × 5.75 × 1.81 in.) Cable length 50 cm (1.64 ft.)
	Weight	590 g (20.8 oz.)

*1 Shielded cables not supported

Included accessories

- CARRYING CASE C0203
- Dimensions: W135 mm (5.31 in.) × H265 mm (10.43 in.) × D65 mm (2.56 in.)
- AA alkaline batteries (LR6) ×4
- Color clips (white ×2, red ×2, blue ×2, yellow ×2)
- Spiral tubes (black ×1)
- Instruction manual
- Options
- MAGNETIC STRAP Z5020

Model PD3259-90 includes Z3210 as a set

Order code **PD3259-50**

Order code **PD3259-90**

Order code **Z3210**

C0203 Color clip Z5020

PHASE DETECTOR PD3129, PD3129-10



Product warranty for 3 years



PD3129: Thin Conductors
φ2.4 mm (0.09 in.) to φ17 mm (0.67 in.)

PD3129-10: Thick Conductors
φ7 mm (0.28 in.) to φ40 mm (1.57 in.)



PD3129 **CAT IV 600 V**

PD3129-10 **CAT IV 600 V, CAT III 1000 V**

Measurement parameters	Detection functions	Phase detection (positive and negative)
	Voltage range	PD3129: 70 to 600 V AC (continuous sine wave) PD3129-10: 70 to 1000 V AC (continuous sine wave)
	Frequency range	45 Hz to 66 Hz
	Measurement targets	PD3129: 2.4 mm (0.09 in.) to 17 mm (0.67 in.) of insulated wiring PD3129-10: 7 mm (0.28 in.) to 40 mm (1.57 in.) of insulated wiring
Phase-detection indication	Positive	4 LEDs lit in clockwise order and the buzzer sounds intermittently, green arrow lights up
	Negative	4 LEDs lit in counterclockwise order and the buzzer sounds continuously
Other	Functions	Live line check, Battery check function
	Operating temperature	0°C to 40°C, 80% RH or less (non-condensating)
	Storage temperature	-20°C to 60°C, 80% RH or less (non-condensating)
	Standards	EN61010 (Safety), EN61326 (EMC)
	Power supply	AA alkaline battery (LR6) × 2
	Continuous operating time	200 hr
	Dimensions (W × H × D)	70 × 75 × 30 mm (2.76 × 2.95 × 1.18 in.) Cable length 70 cm (2.30 ft.)
	Weight	PD3129: 200 g (7.1 oz.), PD3129-10: 240 g (8.5 oz.)

Included accessories

- Carrying case
- Strap
- AA alkaline battery (LR6) ×2
- Spiral tube
- Instruction manual

Order code **PD3129**

Order code **PD3129-10**

VOLTAGE DETECTOR 3481-20



Product warranty for 3 years
Accuracy guaranteed for 1 year



with LED light

Red for voltage detection



CAT IV 600 V

Measurement parameters	Operating voltage range	40 to 600 V AC (50/60Hz)
	Maximum sensitivity variable range	40 to 80 V AC (50/60Hz)
	Pilot light	Red LED lights up and the buzzer sounds when the wire is live
Other	Operating temperature	0°C to 40°C, 80% RH or less (non-condensating)
	Storage temperature	-20°C to 60°C, 80% RH or less (non-condensating)
	Standards	EN61010 (Safety), EN61326 (EMC)
	Power supply	LR44 button alkaline battery × 3
	Continuous operating time	5 hours
	Dimensions (W × H × D)	20 × 126 × 15 mm (0.79 × 4.96 × 0.59 in.)
	Weight	30 g (1.1 oz.)

Included accessories

- LR44 button alkaline battery ×3
- Instruction manual

Order code **3481-20**

Clamp
Insulation
DIMMS
Detectors
Earth
Power quality
Power loggers
Battery
PV
Logger
LAN
Lux
Temperature
Resistance



EARTH TESTER FT6041 Field-capable, Fast-working



**Shorter
work times**

6 sec. measurements

Fast measurement!
Cord rewinding that doesn't tangle or twist



Allowable resistance
100 kΩ

Insert just once thanks to 100 kΩ max.
allowable resistance



Make measurements, even on concrete.
Newly designed Earth Nets Module L9846



IP67

Dirt, sand, and rain resistance
IP67 dust and water protection

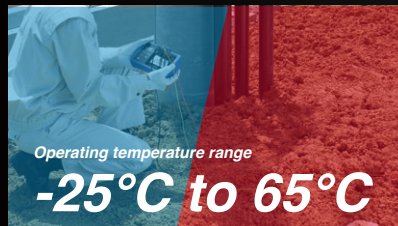

Operating temperature range
-25°C to 65°C

Extreme cold, extreme heat. The FT6041
won't fail, even during extended operation.







With protector attached
Drop-proof design

1 m

Withstands being dropped onto concrete
from a height of 1 m

EARTH TESTERS

Lineup

Model		FT6041	FT6031-50	FT3151	FT6380-50
Appearance					
Ground resistance	Two-pole method	✓	✓	✓	-
	Three-pole method	✓	✓	✓	-
	MEC function	✓	-	-	-
	2-clamp method	✓	-	-	✓
Soil resistivity	Four-pole method	✓	-	-	-
Ground potential		0 to 30.0 V RMS	0 to 30.0 V RMS	0 to 30.0 V RMS	-
Measurement range (ground resistance)		3 Ω to 300 kΩ	20 Ω to 2000 Ω	10 Ω to 1000 Ω	0.20 Ω to 1600 Ω
Measuring frequency		94, 105, 111, 128, 55 Hz	128 Hz	575, 600 Hz	2375 Hz
Allowable ground potential		30 V RMS (DC or sine wave)	25.0 V RMS (DC or sine wave)	10 V	3 V RMS (DC or sine wave)
Allowable resistance of auxiliary grounding electrode		Max. 100 kΩ	Max. 50 kΩ	Max. 5 kΩ	-
Cord winders		✓	✓	✓	-
Operating temperature		-25°C to 65°C (-13°F to 149°F)	-25°C to 65°C (-13°F to 149°F)	0°C to 40°C (32°F to 104°F)	-10°C to 50°C (14°F to 122°F)
Dustproof and waterproof		IP67	IP67	IP40	IP40 with jaws closed
Drop-proof		1 m above concrete (with protector attached)	1 m above concrete (with protector attached)	-	-
Support for Gennect Cross (storage of measured values)		✓	✓	-	✓
Clamp measurement method (maximum measurable conductor diameter)		✓ (with optional sensor) Φ 52 mm (2.05 in.) 78 mm (3.07 in.) × 20 mm (0.79 in.) busbar	-	-	✓ Φ 32 mm (1.26 in.)

Clamp

Insulation

DIMMS

Detectors

Earth

Power quality

Power loggers

Battery

PV

Logger

LAN

Lux

Temperature

Resistance



EARTH TESTER FT6041 Extensive Measurement Functionality

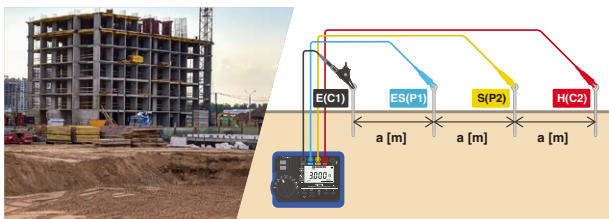

4-pole method

Measure soil resistivity when surveying a grounding design

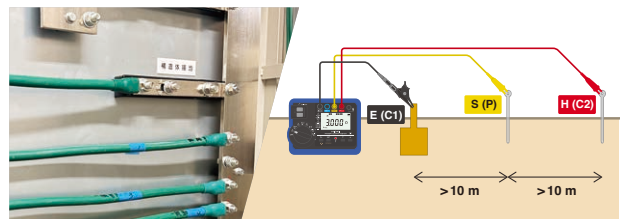

3-pole method

Precisely measure ground resistance

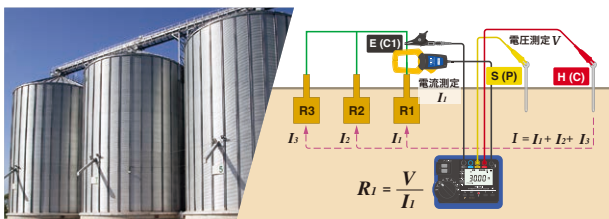

MEC function

MEC stands for "measuring earth with a clamp."

Measure ground resistance without disconnecting ground electrodes

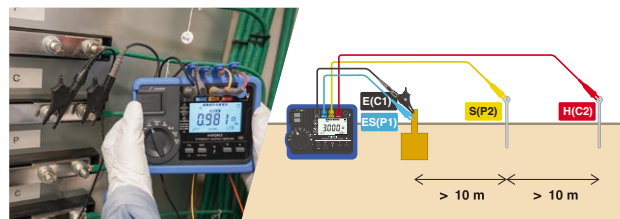

3-pole method using 4-terminal measurement

Measure ground resistance four values of several ohms or less

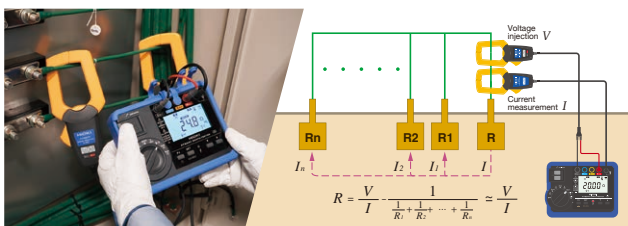

2-clamp method

Measure grounding resistance at multiple grounds



Low-resistance measurement

Continuity test after ground resistance measurement

Clips up to 28 mm (1.10 in.)
Small enough to affix to a busbar

EARTH TESTER FT6041

Product warranty for 3 years
Accuracy guaranteed for 1 year



Extensive measurement functionality

Dustproof and waterproof: **IP67**

4-pole method
Wenner's 4-pole method

3-pole method

2-pole method

Low-resistance measurement

2-clamp method
for multi-grounded systems

MEC function

CAT IV 100 V
CAT III 150 V
CAT II 300 V

With Z3210

Bluetooth

Please see www.hioki.com for list of supported regions.



Gennect Cross



Z3210

Order code **FT6041**

Order code **FT6041-91**

Order code **Z3210**

FT6041-91: FT6041 and included accessories, also includes clamps FT9847 and CT9848

Basic specifications

Measurement parameters	<ul style="list-style-type: none"> Ground resistance measurement: 4-pole method, 3-pole method, 2-pole method, MEC function, clamp-on measurement (two clamps) Soil resistivity measurement: 4-pole method Low-resistance measurement: 4-terminal method, 2-terminal method Ground potential measurement
Ground potential	0 to 30.0 V RMS, accuracy: $\pm 2.3\%$ rdg. ± 8 dgt. (50/60 Hz), $\pm 1.3\%$ rdg. ± 4 dgt. (DC)
Functions	Live wire warning, auto power save, soil resistivity display (4-pole method only), zero-adjustment, auto-hold, continuous measurement mode, wireless communication (only when Z3210 is connected), buzzer sound, comparator, switching the display, ground potential overload display (when measuring ground resistance)
Operating temperature and humidity	-25°C to 65°C^1 (non-condensing)
Storage temperature and humidity	-25°C to 65°C : 80% RH or less (non-condensing)
Dustproof and waterproof	IP65/IP67 (EN60529)
Applicable standards	EN 61010 (safety), EN 61326 (EMC), EN61557-1/EN61557-10/EN61557-14 (low-resistance measurement, earth testers), EN61557-5 (earth testers)
Power supply	HR6 nickel-metal hydride battery x 4 or LR03 alkaline battery x 4
Number of measurements per battery charge ²	500 times (3-pole method, without Z3210 installed) 400 times (3-pole method, with Z3210 installed and using wireless communication)
Dimensions and mass	189 mm (7.44 in.) W x 148 mm (5.83 in.) H x 48 mm (1.89 in.) D, approx. 765 g (27.98 oz.) (including battery, protector)

Ground resistance measurement: 4-pole method, 3-pole method, 2-pole method						
Measurement principle	Apply voltage and measure voltage and current (measures effective resistance by synchronous detection)					
Ground resistance range	3 Ω (0 to 3.000 Ω)	30 Ω (0 to 30.00 Ω)	300 Ω (30.0 Ω to 300.0 Ω)	3000 Ω (300 Ω to 3000 Ω)	30.00 k Ω (3.00 k Ω to 30.00 k Ω)	300.0 k Ω (30.0 k Ω to 300.0 k Ω)
Accuracy	-	$\pm 1.5\%$ rdg. ± 6 dgt.			$\pm 1.5\%$ rdg. ± 4 dgt.	
Allowable resistance of auxiliary grounding electrode	5 k Ω		50 k Ω	100 k Ω		
Allowable ground potential	30 V RMS or 42.4 V peak					
MEC function: 4-pole method with clamp sensor, 3-pole method with clamp sensor						
Measurement principle	Apply voltage and measure voltage and current (measures effective resistance by synchronous detection)					
Ground resistance range	30 Ω (0.00 to 30.00 Ω)	300 Ω (30.0 Ω to 300.0 Ω)	3000 Ω (300 Ω to 3000 Ω)	30.00 k Ω (3 k Ω to 30.00 k Ω)		
Accuracy	$\pm 5\%$ rdg. ± 6 dgt.			$\pm 5\%$ rdg. ± 3 dgt.		
Ground resistance measurement: 2-clamp method						
Measurement principle	Apply voltage and measure voltage and current (measures effective resistance by synchronous detection)					
Ground resistance range	20 Ω (0.02 Ω to 20.00 Ω)	200 Ω (20.0 Ω to 200.0 Ω)	500 Ω (200 Ω to 500 Ω)			
Accuracy	$\pm 7\%$ rdg. ± 3 dgt.			$\pm 35\%$ rdg.		
Low-resistance measurement						
Open-circuit voltage	4.0 V to 6.9 V					
Measuring current	200 mA or more					
Measurement range	30 Ω (0.00 to 30.00 Ω)	300 Ω (30.0 Ω to 300.0 Ω)	3000 Ω (300 Ω to 3000 Ω)			
Accuracy	± 3 dgt. (0.00 to 0.19 Ω) $\pm 2\%$ rdg. ± 2 dgt. (0.20 Ω to 10.00 Ω)		$\pm 2\%$ rdg. ± 2 dgt.			

¹ -25°C to 40°C , -13°F to 104°F (80% RH or less), 40°C to 45°C , 104°F to 113°F (60% RH or less), 45°C to 50°C , 113°F to 122°F (50% RH or less), 50°C to 55°C , 122°F to 131°F (40% RH or less), 55°C to 60°C , 131°F to 140°F (30% RH or less), 60°C to 65°C , 140°F to 149°F (25% RH or less)

² NiMH battery x 4 (reference value at 23°C)



Cord winders make cleanup a snap



Sturdy, thin rods drive easier into the ground



Make measurements, even on concrete.

Included accessories

1	AUXILIARY EARTHING ROD L9840	2 piece set, 270 mm (10.63 in.), Stainless steel
2	MEASUREMENT CABLE L9845-31	Yellow, 25 m (82.02 ft.), equipped with winder
3	MEASUREMENT CABLE L9845-33	Blue, 25 m (82.02 ft.), equipped with winder
4	MEASUREMENT CABLE L9845-52	Red, 50 m (164.04 ft.), equipped with winder
5	MEASUREMENT CABLE L9841	Black 4 m (13.12 ft.) length
6	TEST LEAD L9787	Bundled with line/ground lead, alligator clip, 1.2 m (3.94 ft.) long
7	EARTH NETS MODULE L9846	2 pcs, use with measuring cord set, built-in grounding/earth nets
8	CARRYING CASE C0208	For storing FT6041 and clamp sensors, hard type
9	CARRYING CASE C0209	For storing measurement cables, soft type
10	Protector	Attaches to and protect FT6041
11	LR6 alkaline battery	4 pcs
12	Instruction manual, Operating precautions	

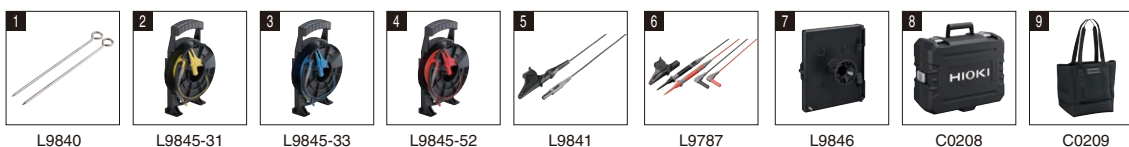

L9840

L9845-31

L9845-33

L9845-52

L9841

L9787

L9846

C0208

C0209



Protector
(attaches to FT6041)

Options

1	SIGNAL INDUCTION CLAMP FT9847	For signal induction, Including resistance check loop
2	CLAMP ON SENSOR CT9848	For detection
3	WIRELESS ADAPTER Z3210	Bluetooth® communication will be possible by attaching to the FT6041
4	MEASUREMENT CABLE L9842-11	Yellow 10 m (32.81 ft.) long, equipped with winder
5	MEASUREMENT CABLE L9842-22	Red 20 m (65.62 ft.) long, equipped with winder
6	MEASUREMENT CABLE L9843-51	Yellow 50 m (164.04 ft.) long, equipped with flat cable winder
7	MEASUREMENT CABLE L9843-52	Red 50 m (164.04 ft.) long, equipped with flat cable winder
8	MEASUREMENT CABLE L9844	For grounding terminal board, red/yellow/black, each 1.2 m (3.94 ft.) long
9	PIN TYPE LEAD 9772	For low-resistance measurement by 4-terminal method
10	LARGE CLIP TYPE LEAD 9467	For low-resistance measurement by 4-terminal method
11	EARTH NETS 9050	2 sheets in set
12	FUSE SET Z5052	



FT9847

CT9848

Z3210

L9842-11

L9842-22

L9843-51

L9843-52

L9844

9772

9467

9050

Z5052

EARTH TESTER FT6031-50

Product warranty for 3 years
Accuracy guaranteed for 1 year 

Dustproof and waterproof: IP67

2-pole
method
Class D3-pole
method
Class A to Class D

CAT IV 100 V

CAT III 150 V

CAT II 300 V

With Z3210

Please see www.hioki.com
for list of supported regions.

Z3210

Order code **FT6031-50**Order code **FT6031-90**Order code **Z3210**

Basic specifications

Measurement system	Two-pole method or three-pole method	
Measurement range	20 Ω (0 to 20.00 Ω)	200 Ω (0 to 200.0 Ω)
Accuracy	±1.5% rdg. ±8 dgt.	±1.5% rdg. ±4 dgt.
Ground potential	0 to 30.0 V RMS Accuracy: ±2.3% rdg. ±8 dgt. (50/60 Hz), ±1.3% rdg. ±4 dgt. (DC)	
Allowable ground potential	25.0 V RMS (DC or sine wave)	
Operating temperature and humidity	-25°C to 65°C ¹ (non-condensing)	
Storage temperature and humidity	-25°C to 65°C (-13°F to 149°F): 80% RH or less (non-condensing)	
Dustproof and waterproof	IP65/IP67 (EN60529)	
Applicable standards	Safety: EN 61010 (main unit), EN 61010 (measuring circuit); EMC: EN 61326; earth testers: EN 61557	
Power supply	LR6 alkaline battery ×4, possible number of measurements for one set of batteries: 500 times (measurement conditions: three-pole method, measuring 10 Ω at 10-second intervals without Z3210 installed)	
Dimensions and mass	185 mm (7.28 in.) W × 111 mm (4.37 in.) H × 44 mm (1.73 in.) D, 570 g (20.1 oz.) (including batteries and protector, excluding terminal covers and other accessories)	

¹ -25°C to 40°C, -13°F to 104°F (80% RH or less), 40°C to 45°C, 104°F to 113°F (60% RH or less), 45°C to 50°C, 113°F to 122°F (50% RH or less), 50°C to 55°C, 122°F to 131°F (40% RH or less), 55°C to 60°C, 131°F to 140°F (30% RH or less), 60°C to 65°C, 140°F to 149°F (25% RH or less)



Cord winders make cleanup a snap



Sturdy, thin rods drive easier into the ground

Included accessories

1	AUXILIARY EARTHING ROD L9840	2 piece set, 270 mm (10.63 in.), Stainless steel
2	MEASUREMENT CABLE L9842-11	Yellow 10 m (32.81 ft.) length, equipped with winder
3	MEASUREMENT CABLE L9842-22	Red 20 m (65.62 ft.) length, equipped with winder
4	MEASUREMENT CABLE L9841	Black 4 m (13.12 ft.) length
5	CARRYING CASE C0106	Soft type, includes compartment for options
6	LR6 alkaline battery	6 pcs
7	Instruction manual	



Options

1	MEASUREMENT CABLE L9843-51	50 m (164.04 ft.)
2	MEASUREMENT CABLE L9843-52	50 m (164.04 ft.)
3	MEASUREMENT CABLE L9844	For earthing terminal board red/yellow/black 1.2 m (3.94 ft.) each
4	TEST LEAD L9787	For simplified measurement method
5	WIRELESS ADAPTER Z3210	Bluetooth® communication will be possible by attaching to the FT6031-50
6	EARTH NETS 9050	2 sheets in set



9050

Ground types

Type	Criterion	Locations used
Class A	10 Ω or less	Special high voltage, high voltage
Class B	As per calculations	Transformer neutral point
Class C	10 Ω or less* 500 Ω or less*	Low voltages in excess of 300 V
Class D	10 Ω or less* 500 Ω or less*	Low voltages of 300 V or less

3

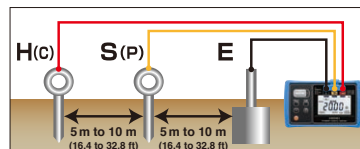
electrode
method
(classes A to D)

Measurement is performed after inserting an auxiliary grounding rod into the soil. For accurate measurement, position E-S(P)-H(C) in a straight line at an interval of about 5 to 10 m.

2

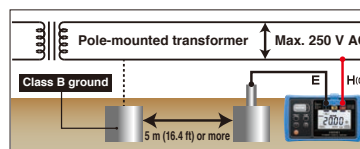
electrode
method
(classes D)

Class D ground installations can be measured by using the Class B ground of a pole-mounted transformer. The measured value will include the resistance value of the Class B ground. The distribution panel's main ground terminal is typically connected to the power supply's ground line.

*With ground-fault interrupter that trips within 0.5 sec.

EARTH TESTER FT3151

Product warranty for 3 years
Accuracy guaranteed for 1 year



Rewind with ease

2-pole method
Class D

3-pole method
Class A to Class D

CAT II 300 V

Order code **FT3151**

Basic specifications

Measurement parameters	Measurement system	Two-electrode method (Class D) Three-electrode method (Class A to D)
	Range configuration	10 Ω (0 to 11.5 Ω): ±0.25 Ω 100 Ω (0 to 115 Ω): ±2.5 Ω 1000 Ω (0 to 1150 Ω): ±25 Ω
	Accuracy	Earth potential: Accuracy 0 to 30 V: ±3.0% f.s.
	Operating temperature	0°C to 40°C, 80% RH or less (non-condensating)
Other	Storage temperature	-10°C to 50°C, 80% RH or less (non-condensating)
	Dustproof and waterproof	IP40 (EN60529)
	Standards	EN61010 (Safety, measuring circuit, probe), EN61326 (EMC), EN61557-1/-5 (Earth tester)
	Power supply	LR6 alkaline battery x 6
	Number of uses	1100 times ¹
	Dimensions (W x H x D)	164 x 119 x 88 mm (6.46 x 4.69 x 3.46 in.)
Weight	760 g (26.8 oz.)	

¹30 sec. measurement and 30 sec. rest, 3-electrode method, 575 Hz, auxiliary grounding electrode resistance of 100 Ω, measuring 10 Ω in the instrument's x 1 Ω range

Included accessories		
1	AUXILIARY EARTHING ROD L9840	2 piece set, 270 mm (10.63 in.), Stainless steel
2	MEASUREMENT CABLE L9842-11	Yellow 10 m (32.81 ft.) length, equipped with winder
3	MEASUREMENT CABLE L9842-22	Red 20 m (65.62 ft.) length, equipped with winder
4	MEASUREMENT CABLE L9841	Black 4 m (13.12 ft.) length
5	CARRYING CASE C0106	Soft type, includes compartment for options
6	LR6 alkaline battery	6 pieces
7	Instruction manual	



Options	
1	MEASUREMENT CABLE L9843-51 50 m (164.04 ft.)
2	MEASUREMENT CABLE L9843-52 50 m (164.04 ft.)
3	MEASUREMENT CABLE L9844 For earthing terminal board red/yellow/black 1.2 m (3.94 ft.) each
4	TEST LEAD L9787 For simplified measurement method
5	SHOULDER STRAP Z5022
6	EARTH NETS 9050 2 sheets in set



Cord winders make cleanup a snap



Sturdy, thin rods drive easier into the ground

CLAMP ON EARTH TESTER FT6380-50

Product warranty for 3 years
Accuracy guaranteed for 1 year



For multi-grounded systems only

Clamp-on method

Current measurement
True RMS

CAT IV 600 V

WIRELESS ADAPTER Z3210 (option): Attach to enable Bluetooth® wireless technology

Model FT6380-90 includes Z3210 as a set

Order code **FT6380-50**

Order code **FT6380-90**

Order code **Z3210**

With Z3210

Bluetooth®
Please see www.hioki.com for list of supported regions.

Z3210

Gennect Cross

Included accessories



Carrying case Resistance check loop

- Carrying case
- Resistance check loop (1 Ω, 25 Ω)
- Strap
- LR06 alkaline battery x2
- Instruction manual

Measurements for Multi-Grounded Systems



Hazardous Storage Tanks

Transmission Towers

Measurement parameters	Measurement system	Instrument has two cores for voltage injection and current measurement. Total circuit loop resistance is calculated from defined voltage and measured current. ¹
	Earthing resistance range	0.20 Ω, 2.00 Ω, 20.00 Ω, 50.0 Ω, 100.0 Ω, 200.0 Ω, 400 Ω, 600 Ω, 1200 Ω, 1600 Ω Guaranteed accuracy range: 0.02 Ω to 1600 Ω Accuracy: ±1.5% rdg. ±0.02 Ω
	AC Current range	20.00 mA, 200.0 mA, 2.000 A, 20.00 A, 60.0 A Guaranteed accuracy range: 1.00 mA to 60.0 A Accuracy: ±2.0% rdg. ±0.05 mA
Other	Operating temperature	-10°C to 50°C, 80% RH or less (non-condensating)
	Storage temperature	-20°C to 60°C, 80% RH or less (non-condensating)
	Dustproof and waterproof	IP40 (EN60529) ²
	Standards	EN61010 (Safety), EN61326 (EMC)
Other	Power supply	LR6 alkaline battery x 2
	Continuous operating time	35 hours (backlight OFF)
	Dimensions (W x H x D)	73 x 218 x 43 mm (2.87 x 8.58 x 1.69 in.)
Weight	620 g (21.9 oz.)	

¹For multi-grounded systems only. In a multi-grounded system, the larger the number of grounding poles, the more accurate the measured value.

²When jaw closes

Clamp

Insulation

DIMMS

Detectors

Earth

Power quality

Power loggers

Battery

PV

Logger

LAN

Lux

Temperature

Resistance



**POWER QUALITY ANALYZER PQ3198, PQ3100
Monitor Power Quality and Analyze
the Cause of Equipment Issues**

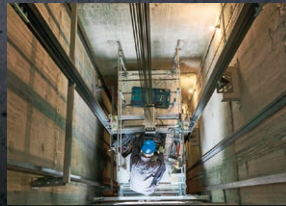

Power anomalies are a major cause of equipment malfunction and damage. The PQ3198 and PQ3100 detect power supply abnormalities without fail to help diagnose the cause of problems.

Capture all of these power anomalies simultaneously

- Transient voltages
- Voltage swells
- Voltage dips
- Interruptions
- Frequency fluctuations
- Inrush current
- Harmonics
- High-order harmonics (Supraharmonics)

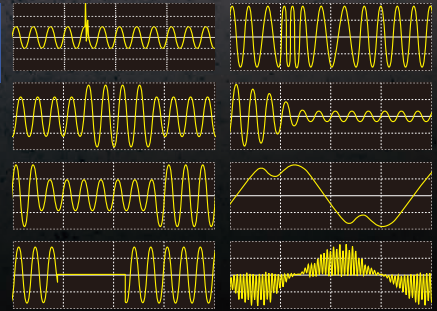

POWER QUALITY ANALYZERS



POWER QUALITY ANALYZER PQ3198, PQ3100

Product warranty for 3 years
Accuracy guaranteed for 1 year

Shared features: Side

Left side

Right side

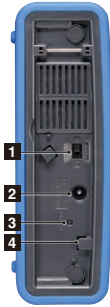

- 1 Power switch
- 2 AC adapter terminal
- 3 Charging indicator
- 4 Cable hook

- 5 Strap attachment point
- 6 SD card terminal
- 7 USB terminal
- 8 LAN terminal
- 9 RS-232C terminal
- 10 External I/O terminal



PQ3198 (High-end model)
CAT IV 600 V



Voltage input terminals (4 channels: channels 1/2/3 and channel 4 are isolated from each other)
Current input terminals (4 channels)



PQ3100 (Standard model)
CAT IV 600 V, CAT III 1000 V



Voltage input terminals (4 channels)
Current input terminals (4 channels)

Model	PQ3198 (High-end model)	PQ3100 (Standard model)
Measurement lines	1-phase/2-wire, 1-phase/3-wire, 3-phase/3-wire, 3-phase/4-wire + CH 4	
Fundamental frequency	DC, 50 Hz, 60 Hz, 400 Hz	DC, 50 Hz, 60 Hz
Voltage ranges Accuracy	Voltage measurement: 600.00 V rms Transient measurement: 6.0000 kV peak ±0.1% of nominal voltage	Voltage measurement: 1000.0 V rms or DC Transient measurement: 2.200 kV peak ±0.2% of nominal voltage
Current ranges Accuracy	500.00 mA to 5.0000 kA AC (Depends on current sensor in use) ±0.1% rdg. ±0.1% f.s. + current sensor accuracy	(AC) 50.000 mA to 5.0000 kA (Depends on current sensor in use) (DC) 10.000 A to 2.0000 kA (Depends on current sensor in use) ±0.1% rdg. ±0.1% f.s. + current sensor accuracy
Power ranges Accuracy	300.00 W to 3.0000 MW (AC) ±0.2% rdg. ±0.1% f.s. + current sensor accuracy (DC) ±0.5% rdg. ±0.5% f.s. + current sensor accuracy (CH4 Only)	50.000 W to 6.0000 MW (AC) ±0.2% rdg. ±0.1% f.s. + current sensor accuracy (DC) ±0.5% rdg. ±0.5% f.s. + current sensor accuracy
Measurement parameters	<ol style="list-style-type: none"> Transient voltage: 2MHz sampling Frequency cycle: calculated as one cycle Voltage (1/2) RMS: one cycle calculation refreshed every half cycle Current (1/2) RMS: half-cycle calculation Voltage swell, voltage dips, voltage interruption Inrush current Voltage waveform comparison Instantaneous flicker value: As per IEC61000-4-15 200 ms frequency: calculated as 10 or 12 cycles, 40 to 70 Hz 10 sec frequency: calculated as the whole-cycle time during the specified 10 s period, 40 to 70 Hz Voltage waveform peak, Current waveform peak Voltage, current, active power, apparent power, reactive power, active energy, reactive energy, power factor, displacement power factor, voltage unbalance factor, current unbalance factor, and efficiency High-order harmonic (Supraharmonic) component (voltage/current): 2 kHz to 80 kHz Harmonic value and Harmonic phase angle (voltage/current), harmonic power: 0th to 50th orders Harmonic voltage-current phase angle: 1st to 50th orders Total harmonic distortion factor (voltage/current) Inter harmonic (voltage/current): 0.5th to 49.5th order K Factor (multiplication factor) IEC Flicker, Δ V10 Flicker 	<ol style="list-style-type: none"> Transient voltage: 200 kHz sampling Frequency cycle: calculated as one cycle Voltage (1/2) RMS and Current (1/2) RMS: one cycle calculation refreshed every half cycle Voltage swell, voltage dips, voltage interruption, RVC: Voltage (1/2) RMS calculation Inrush current Frequency 200 ms: calculated as 10 or 12 cycles 10-sec frequency: calculated as the whole-cycle time during the specified 10 s period Voltage waveform peak, current waveform peak Voltage, current, active power, apparent power, reactive power, active energy, apparent energy, reactive energy, energy cost, power factor, displacement power factor, voltage unbalance factor, current unbalance factor Voltage crest factor, current crest factor Harmonic/Harmonic phase angle (voltage/current), harmonic power: 0th to 50th orders Harmonic voltage-current phase angle: 1st to 50th orders Total harmonic distortion factor (voltage/current) Inter harmonic (voltage/current): 0.5th to 49.5th orders K Factor (multiplication factor) IEC Flicker, Δ V10 Flicker
Record	Repeated ON: 1 year, maximum recording event: 9999 × 366 days (up to 9999 events per day) Repeated off: 35 days, maximum recording event: 9999 events	Maximum recording interval: 1 year, maximum number of recordable events: 9999 × 365 days
Setup assistance	Simplified setup function	QUICK SET (navigation-style assistance from connecting the instrument to the start of recording)
Interfaces	SD/SDHC memory card (Use only SD cards sold by HIOKI. Compatibility and performance are not guaranteed for SD cards made by other manufacturers.), RS-232C, USB2.0, LAN	
Operating temperature	0°C to 30°C (95% RH or less), 30°C to 50°C (80% RH or less) (non-condensating)	-20°C to 50°C (80% RH or less) (non-condensating)
Storage temperature	10°C greater than operating temperature and humidity range	
Standards	EN61010 (Safety), EN61326 Class A (EMC)	
IEC 61000-4-30	Class A	Class S
Power supply	AC ADAPTER Z1002, BATTERY PACK Z1003	
Battery operating time	3 hours	8 hours
Dimensions (W × H × D)	300 × 211 × 68 mm (11.81 × 8.31 × 2.68 in.)	
Weight	2.6 kg (91.7 oz.) (including BATTERY PACK)	2.5 kg (88.2 oz.) (including BATTERY PACK)



PQ3198 Included accessories

- VOLTAGE CORD L1000
- AC ADAPTER Z1002
- BATTERY PACK Z1003
- SD MEMORY CARD Z4001
- USB cable
- Color clips
- Spiral tubes
- Strap
- Measurement guide
- User manual

PQ3100 Included accessories

- VOLTAGE CORD L1000-05
- AC ADAPTER Z1002
- BATTERY PACK Z1003
- USB cable
- Color clips
- Spiral tubes
- Strap
- Measurement guide
- User manual

Order code **PQ3198**

Order code **PQ3198-92** Value Kits: PQ3198, CT7136 (600A) × 4, L1021-02×3, CARRYING CASE C1009

Order code **PQ3198-94** Value Kits: PQ3198, CT7045 (6000A) × 4, L1021-02×3, CARRYING CASE C1009

Order code **PQ3100**

Order code **PQ3100-91** Value Kits: PQ3100, CT7136 (600A) × 2, SD MEMORY CARD 2GB Z4001, CARRYING CASE C1009

Order code **PQ3100-92** Value Kits: PQ3100, CT7136 (600A) × 4, SD MEMORY CARD 2GB Z4001, CARRYING CASE C1009

Order code **PQ3100-94** Value Kits: PQ3100, CT7045 (6000A) × 4, SD MEMORY CARD 2GB Z4001, CARRYING CASE C1009

*For more detailed information on CT7136, CT7045, and options, please refer to p.48.



CLAMP ON POWER LOGGER PW3365, PW3360
Accurately Measure Power Consumption, also Available with Non-contact Voltage Sensor for Added Safety

SAFETY VOLTAGE SENSOR PW9020
 (for PW3365 only)

- Clamp on top of cable insulation
- Quick setup
- Safely avoid contact/with live parts



Compared with standard alligator clips that are hard to use and require metal-to-metal contact



Toggle displays to easily verify data



List display



Waveform

Demand Graph



Trend Graph

QUICK SET navigation

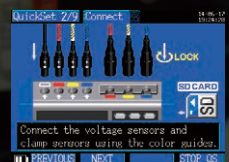

Highly Intuitive

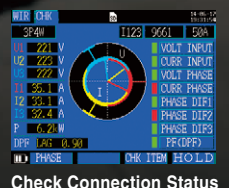

Check Connection Status

POWER LOGGERS



CLAMP ON POWER LOGGER PW3365, PW3360

Product warranty for 3 years
Accuracy guaranteed for 1 year



SAFETY VOLTAGE SENSOR PW9020
Compatible with PW3365 only
Finished outer diameter
Φ6 mm (0.24 in.) to Φ30 mm (1.18 in.)



PW3365



CAT IV 300 V, CAT III 600 V



PW3360



CAT IV 300 V, CAT III 600 V

Model	PW3365 + PW9020	PW3360
Measurement line	1-phase/2-wire (1/2/3 circuits), 1-phase/3-wire (1 circuit), 3-phase/3-wire (1 circuit), 3-phase/4-wire (1 circuit), Current only: 1 to 3 channels	
Frequency	50 Hz/60 Hz	
Voltage ranges	400 V AC (Effective measurement range: 90.0 V to 520.0 V)	600 V AC (Effective measurement range: 90.0 V to 780.0 V)
Accuracy	±1.5% rdg. ±0.2% f.s. (combined accuracy with PW9020)	±0.3% rdg. ±0.1% f.s.
Current ranges	500.00 mA AC to 5.0000 kA ¹ (Leak clamp on sensor only: 50.0000 mA AC to 5.0000 A)	
Accuracy	±0.3% rdg. ±0.1% f.s. + current sensor accuracy	
Power ranges	200.00 W to 6.0000 MW	300.00 W to 9.0000 MW
Accuracy	±2.0% rdg. ±0.3% f.s. + current sensor accuracy	±0.3% rdg. ±0.1% f.s. + current sensor accuracy
Measurement parameters	Voltage	RMS value, fundamental wave value, waveform peak (absolute value), fundamental wave phase angle, frequency (U1)
	Current	RMS value, fundamental wave value, waveform peak (absolute value), fundamental wave phase angle
	Power	Active power, reactive power, apparent power, power factor, (with lag, lead display) or displacement power factor (with lag, lead display), active energy (consumption, regeneration), reactive energy (lag, lead), Energy cost display (per-kWh price × power consumption)
	Demand	Active power demand value (consumption, regeneration), reactive power demand value (lag, lead), Active power demand quantity (consumption, regeneration), reactive power demand quantity (lag, lead), power factor demand value
	Harmonics	PW3360-21 Only: Harmonic voltage, current, power level, content, phase angle, total harmonic distortion factor (THD-F or THD-R), up to the 40th order
	Pulse input	N / A
Data save interval	1 sec to 30 sec, 1 minute to 60 minutes, 14 selections	
Interfaces	SD/ SDHC memory card ² , LAN, USB2.0, FTP	
Operating temperature	0°C to 50°C, 80% RH or less (non-condensating)	-10°C to 50°C, 80% RH or less (non-condensating)
Storage temperature	-10°C to 60°C, 80% RH or less (non-condensating)	-20°C to 60°C, 80% RH or less (non-condensating)
Standards	EN61010 (Safety), EN61326 (EMC)	
Power supply	AC ADAPTER Z1008, BATTERY PACK 9459	AC ADAPTER Z1006, BATTERY PACK 9459
Battery operating time	3 hours	5 hours
Dimensions (W × H × D)	180 × 100 × 68 mm (7.09 × 3.94 × 2.68 in.) (with PW9002)	180 × 100 × 67.2 mm (7.09 × 3.94 × 2.65 in.) (with PW9002)
Weight	820 g (28.9 oz.) (with PW9002)	830 g (29.3 oz.) (with PW9002)

SAFETY VOLTAGE SENSOR PW9020 Specifications

Compatible conductor types	Insulated wires ³ (indoor PVC) or metal parts
Compatible conductor diameters	Finished outer diameter Φ6 mm to Φ30 mm (Φ0.24 in. to Φ1.18 in.)
Effective measurement range	90 V to 520 V
Safety standard category	CAT IV 300 V/CAT III 600 V
Operating temperature	0°C to 50°C, 80% RH or less (non-condensating)
Storage temperature	-10°C to 60°C, 80% RH or less (non-condensating)
Standards	EN61010 (Safety), EN61326 (EMC)
Cord length	3 m (9.84 ft.)
Weight	220 g (7.8 oz.)

¹ Depends on current sensor in use. For more detailed information on sensors, please refer to p.49.

² Use only SD Cards sold by HIOKI. Compatibility and performance are not guaranteed for PC cards made by other manufacturers.

³ Shielded wires cannot be measured. The product may not be able to accurately measure multicore cables or cables that have thick insulation.



PW3360 Included accessories

- VOLTAGE CORD L9438-53 (black, red, yellow, blue @ 1 each)
- AC ADAPTER Z1006
- USB cable 0.9 m (2.95 ft.)
- Instruction manual, Measurement guide
- Color clips (red, blue, yellow, white @ 2 each)
- Spiral tubes × 5

PW3365 Included accessories

- SAFETY VOLTAGE SENSOR PW9020 × 4
- AC ADAPTER Z1008
- USB cable 0.9 m (2.95 ft.)
- Instruction manual, Measurement guide
- Color clips (red, blue, yellow, white @ 4 each)
- Spiral tubes × 10

Order code **PW3365-20**

Order code **PW3360-20**

Order code **PW3360-21** with harmonic analysis function

Clamp

Insulation

DIMMS

Detectors

Earth

Power quality

Power loggers

Battery

PV

Logger

LAN

Lux

Temperature

Resistance

Options

For PQ3198, PQ3100		
Voltage	1	VOLTAGE CORD L1000 Red/Yellow/Blue/Gray @ 1 each, Black x 4, 3 m (9.84 ft.), Alligator clip x 8
	2	VOLTAGE CORD L1000-05 Red/Yellow/Blue/Gray/Black @ 1 each 1, 3 m (9.84 ft.), Alligator clip x 5
	3	MAGNETIC ADAPTER 9804-01 Red, Alternative tip for the L1000, L1000-05
	4	MAGNETIC ADAPTER 9804-02 Black, Alternative tip for the L1000, L1000-05
	5	GRABBER CLIP L9243 Alternative tip for the L1000, L1000-05
	6	PATCH CORD L1021-01* 0.5 m (1.64 ft.), Red, Banana branch-banana
Record	7	PATCH CORD L1021-02* 0.5 m (1.64 ft.), Black, Banana branch-banana
	8	SD MEMORY CARD 2GB Z4001 Use only SD Cards sold by HIOKI. Compatibility and performance are not guaranteed for PC cards made by other manufacturers.
Communication	9	SD MEMORY CARD 8GB Z4003
	10	RS-232C CABLE 9637 For PQ3100, pin - 9 pin, cross, 1.8 m (5.91 ft.)
Power supply	11	LAN CABLE 9642 5 m (16.4 ft.), Straight, Cross conversion adapter
	12	AC ADAPTER Z1002 100 V AC to 240 V AC
Connection	13	BATTERY PACK Z1003 7.2 V, Ni-MH
	14	WIRING ADAPTER PW9000 For PQ3198, for 3-phase/3-wire connection
Other	15	WIRING ADAPTER PW9001 For PQ3198, for 3-phase/4-wire connection
	16	GPS BOX PW9005 For PQ3198
Other	17	CARRYING CASE C1009 Bag type
	18	CARRYING CASE C1002 Hard trunk type
	19	MAGNETIC STRAP Z5004
	20	MAGNETIC STRAP Z5020 Extra strength



* Only for PQ3198



Product warranty for 3 years
Accuracy guaranteed for 1 year

CURRENT SENSOR for PQ3198, PQ3100

Features	Make measurements over extended period of time without zero-adjustment, even in locations with temperature variations			AC/DC current sensors for observing instantaneous waveforms		
Model name	AC/DC AUTO-ZERO CURRENT SENSOR			AC/DC CURRENT SENSOR		
Model	CT7731	CT7736	CT7742	CT7631	CT7636	CT7642
Appearance						
Rated measurement current	100 A AC/DC	600 A AC/DC	2000 A AC/DC	100 A AC/DC	600 A AC/DC	2000 A AC/DC
Max. allowable peak input	150 A peak	900 A peak	2840 A peak	150 A peak	900 A peak	2840 A peak
Bandwidth	DC to 5 kHz (-3dB)	DC to 5 kHz (-3dB)	DC to 5 kHz (-3dB)	DC to 10 kHz (-3dB)	DC to 10 kHz (-3dB)	DC to 10 kHz (-3dB)
Amplitude accuracy (DC, 45 to 66 Hz)	±1.0% rdg. ±0.5% f.s.	±2.0% rdg. ±0.5% f.s.	±1.5% rdg. ±0.5% f.s.	±1.0% rdg. ±0.5% f.s.	±2.0% rdg. ±0.5% f.s.	±1.5% rdg. ±0.5% f.s.
Output rate	1 mV/A	1 mV/A	0.1 mV/A	1 mV/A	1 mV/A	0.1 mV/A
Max. rated voltage to earth	(AC/DC) CAT IV 600 V	(AC/DC) CAT IV 600 V, CAT III 1000 V	(AC/DC) CAT IV 600 V, CAT III 1000 V	(AC/DC) CAT IV 600 V	(AC/DC) CAT IV 600 V, CAT III 1000 V	(AC/DC) CAT IV 600 V, CAT III 1000 V
Operating temperature	-25°C to 65°C	-25°C to 65°C	-25°C to 65°C	-25°C to 65°C	-25°C to 65°C	-25°C to 65°C
Core jaw diameter	Φ33 mm or less	Φ33 mm or less	Φ55 mm or less	Φ33 mm or less	Φ33 mm or less	Φ55 mm or less

Features	Attaches easily to thick cables, even in confined spaces			For accurately measuring load current			For measuring leakage current
Model name	AC FLEXIBLE CURRENT SENSOR			AC CURRENT SENSOR			AC LEAKAGE CURRENT SENSOR
Model	CT7044	CT7045	CT7046	CT7126	CT7131	CT7136	CT7116
Appearance							
Rated measurement current	6000 A AC	6000 A AC	6000 A AC	60 A AC	100 A AC	600 A AC	6 A AC
Max. allowable peak input	15000 A peak	15000 A peak	15000 A peak	100 A peak	200 A peak	900 A peak	30 A peak
Bandwidth	10 to 50 kHz (within ±3 dB)	10 to 50 kHz (within ±3 dB)	10 to 50 kHz (within ±3 dB)	40 to 20 kHz	40 to 20 kHz	40 to 20 kHz	40 to 5 kHz
Amplitude accuracy (45 to 66 Hz)	±1.5% rdg. ±0.25% f.s.*	±1.5% rdg. ±0.25% f.s.*	±1.5% rdg. ±0.25% f.s.*	±0.3% rdg. ±0.01% f.s.	±0.3% rdg. ±0.02% f.s.	±0.3% rdg. ±0.01% f.s.	±1.0% rdg. ±0.05% f.s.
Output rate	1 mV/A (600 A) 0.1 mV/A (6000 A)	1 mV/A (600 A) 0.1 mV/A (6000 A)	1 mV/A (600 A) 0.1 mV/A (6000 A)	10 mV/A	1 mV/A	1 mV/A	100 mV/A
Max. rated voltage to earth	(AC) CAT IV 600 V, CAT III 1000 V	(AC) CAT IV 600 V, CAT III 1000 V	(AC) CAT IV 600 V, CAT III 1000 V	(AC) CAT III 300 V	(AC) CAT III 300 V	(AC) CAT IV 600 V, CAT III 1000 V	Insulated conductor
Operating temperature	-25°C to 65°C	-25°C to 65°C	-25°C to 65°C	-10°C to 50°C	-10°C to 50°C	-10°C to 50°C	-25°C to 65°C
Core jaw diameter	Φ100 mm or less	Φ180 mm or less	Φ254 mm or less	Φ15 mm or less		Φ46 mm or less	Φ40 mm or less

*At center of flexible loop

1	EXTENSION CABLE L0220-01	2 m (6.56 ft.), for PL14 connectors
2	EXTENSION CABLE L0220-02	5 m (16.4 ft.), for PL14 connectors
3	EXTENSION CABLE L0220-03	10 m (32.81 ft.), for PL14 connectors
4	EXTENSION CABLE L0220-04	20 m (65.62 ft.), for PL14 connectors
5	EXTENSION CABLE L0220-05	30 m (98.43 ft.), for PL14 connectors
6	EXTENSION CABLE L0220-06	50 m (164.04 ft.), for PL14 connectors
7	EXTENSION CABLE L0220-07	100 m (328.08 ft.), for PL14 connectors



L0220

Clamp
Insulation
DIMMS
Detectors
Earth
Power quality

Power loggers
Battery
PV
Logger
LAN
Lux
Temperature
Resistance

Options

For PW3365, PW3360		
Voltage	1	SAFETY VOLTAGE SENSOR PW9020 For PW3365, 3 m (9.84 ft.)
	2	VOLTAGE CORD L9438-53 For PW3360, Black/ Red/ Yellow/ Blue, 3 m (9.84 ft.) length, Alligator clip x 4
	3	MAGNETIC ADAPTER 9804-01 For PW3360, Red, Φ 11 mm (0.43 in.)
	4	MAGNETIC ADAPTER 9804-02 For PW3360, Black, Φ 11 mm (0.43 in.)
	5	PATCH CORD L1021-01 For PW3360, 0.5 m (1.64 ft.), Red, Banana branch-banana
	6	PATCH CORD L1021-02 For PW3360, 0.5 m (1.64 ft.), Black, Banana branch-banana
Record	7	SD MEMORY CARD 2GB Z4001 Use only SD Cards sold by HIOKI. Compatibility and performance are not guaranteed for PC cards made by other manufacturers.
	8	SD MEMORY CARD 8GB Z4003
Communication	9	LAN CABLE 9642 5 m (16.4 ft.), Straight, Cross conversion adapter
	10	POWER LOGGER VIEWER SF1001 Software to analyze measurement data
Power supply	11	AC ADAPTER Z1008 For PW3365, 100V AC to 240V
	12	AC ADAPTER Z1006 For PW3360, 100V AC to 240V
	13	BATTERY SET PW9002 Battery case and 9459 Set
	14	BATTERY PACK 9459
Other	15	CARRYING CASE C1005
	16	CARRYING CASE C1008 For PW3365
	17	MAGNETIC STRAP Z5004



Product warranty for 3 years
Accuracy guaranteed for 1 year

CURRENT SENSOR for PW3365, PW3360

Features	For load current levels: Voltage output					
Model name	CLAMP ON SENSOR					
Model	9694	9660	9661	9669	9695-02	9695-03
Appearance						
Rated measurement current	5 A AC	100 A AC	500 A AC	1000 A AC	50 A AC	100 A AC
Output rate	10 mV/A	1 mV/A	1 mV/A	0.5 mV/A	10 mV/A	1 mV/A
Amplitude accuracy (45 to 66 Hz)	$\pm 0.3\%$ rdg. $\pm 0.02\%$ f.s.	$\pm 0.3\%$ rdg. $\pm 0.02\%$ f.s.	$\pm 0.3\%$ rdg. $\pm 0.01\%$ f.s.	$\pm 1.0\%$ rdg. $\pm 0.01\%$ f.s.	$\pm 0.3\%$ rdg. $\pm 0.02\%$ f.s.	$\pm 0.3\%$ rdg. $\pm 0.02\%$ f.s.
Max. rated voltage to earth	(AC) CAT III 300 V	(AC) CAT III 300 V	(AC) CAT III 600 V	(AC) CAT III 600 V	(AC) CAT III 300 V	(AC) CAT III 300 V
Operating temperature	0°C to 50°C	0°C to 50°C	0°C to 50°C	0°C to 50°C	0°C to 50°C	0°C to 50°C
Core jaw diameter	Φ 15 mm or less	Φ 15 mm or less	Φ 46 mm or less	Φ 55 mm or less 80x20 mm busbar	Φ 15 mm or less	Φ 15 mm or less

Features	For load current levels: Voltage output			For leak current: Voltage output	
	AC FLEXIBLE CURRENT SENSOR			CLAMP ON LEAK SENSOR	
Model name					
Model	CT9667-01	CT9667-02	CT9667-03	9657-10	9675
Appearance					
Rated measurement current	5000 A AC/500 A AC	5000 A AC/500 A AC	5000 A AC/500 A AC	10 A AC	10 A AC
Output rate	0.1 mV/A (5000 A) 1 mV/A (500 A)	0.1 mV/A (5000 A) 1 mV/A (500 A)	0.1 mV/A (5000 A) 1 mV/A (500 A)	100 mV/A	100 mV/A
Amplitude accuracy (45 to 66 Hz)	$\pm 2\%$ rdg. $\pm 0.3\%$ f.s.*	$\pm 2\%$ rdg. $\pm 0.3\%$ f.s.*	$\pm 2\%$ rdg. $\pm 0.3\%$ f.s.*	$\pm 1.0\%$ rdg. $\pm 0.05\%$ f.s.	$\pm 1.0\%$ rdg. $\pm 0.005\%$ f.s.
Max. rated voltage to earth	(AC) CAT IV 600 V (AC) CAT III 1000 V	(AC) CAT IV 600 V (AC) CAT III 1000 V	(AC) CAT IV 600 V (AC) CAT III 1000 V	Insulated conductor	Insulated conductor
Operating temperature	-25°C to 65°C	-25°C to 65°C	-10°C to 50°C	0°C to 50°C	0°C to 50°C
Core jaw diameter	Φ 100 mm or less	Φ 180 mm or less	Φ 254 mm or less	Φ 40 mm or less	Φ 30 mm or less

*At center of flexible loop

1	EXTENSION CABLE L0220-01	2 m (6.56 ft.), for PL14 connectors
2	EXTENSION CABLE L0220-02	5 m (16.4 ft.), for PL14 connectors
3	EXTENSION CABLE L0220-03	10 m (32.81 ft.), for PL14 connectors
4	EXTENSION CABLE L0220-04	20 m (65.62 ft.), for PL14 connectors
5	EXTENSION CABLE L0220-05	30 m (98.43 ft.), for PL14 connectors
6	EXTENSION CABLE L0220-06	50 m (164.04 ft.), for PL14 connectors
7	EXTENSION CABLE L0220-07	100 m (328.08 ft.), for PL14 connectors
8	CONNECTION CABLE 9219	For 9695, 3 m (9.84 ft.)
9	AC ADAPTER 9445-02	For CT9667
10	CONVERSION CABLE L9910	To convert output connector: BNC to PL 14



Clamp
Insulation
DIMMS
Detectors
Earth
Power quality
Power loggers
Battery
PV
Logger
LAN
Lux
Temperature
Resistance



BATTERY TESTER BT3554-50, BT3554-51, BT3554-52

Properly Diagnose Deterioration of UPS Lead-acid Batteries even Under Noisy Environments

Tough against inverter noise during UPS startup

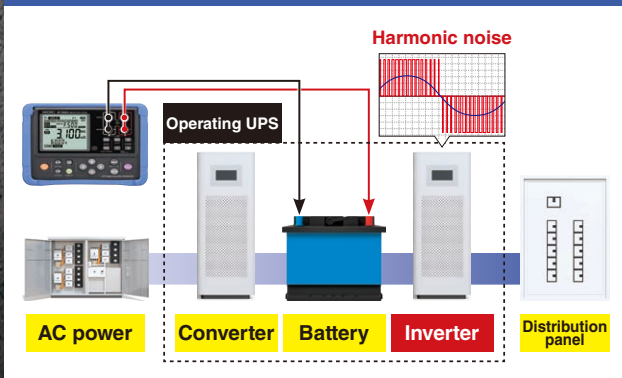

Completing an intensive inspection workload efficiently

The app provides audio guidance about the battery measurement sequence. And, automatically saves the measurement results.

1 2 3 4 5 ... 500

NEXT: Battery No.1
Receive measurement results
No.1 PASS

BATTERY TESTERS



BATTERY TESTER BT3554-50, BT3554-51, BT3554-52

Product warranty for 3 years
Accuracy guaranteed for 1 year



WIRELESS ADAPTER Z3210 (options): Attach to enable Bluetooth® wireless technology

BT3554-50: Instrument only

With Z3210



Please see www.hioki.com for list of supported regions.



Gennect Cross

BT3554-51: with 9465-10

With Z3210



Please see www.hioki.com for list of supported regions.



Gennect Cross

BT3554-52: with L2020

With Z3210



Please see www.hioki.com for list of supported regions.



Gennect Cross

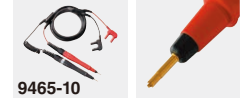

9465-10



L2020

Included accessories

- PIN TYPE LEAD 9465-10 (BT3554-51 only)
- PIN TYPE LEAD L2020 (BT3554-51 only)
- Carrying Case C1014
- Protector Z5041
- Fuse Set Z5050
- ZERO ADJUSTMENT BOARD
- Neck strap
- USB cable
- Power-on option sticker
- Alkaline battery LR6 × 8
- Instruction manual

Order code **BT3554-50** Instrument only

Order code **BT3554-51** With 9465-10

Order code **BT3554-52** With L2020

Order code **BT3554-91** With 9465-10, Z3210

Order code **BT3554-92** With L2020, Z3210

Order code **Z3210**

Options

1	PIN TYPE LEAD L2020	
2	PIN TYPE LEAD 9465-10	
3	PIN TYPE LEAD 9772	
4	CLIP TYPE LEAD WITH TEMPERATURE SENSOR 9460	
5	LARGE CLIP TYPE LEAD 9467	
6	TIP PIN 9465-90	For L2020, 9465-90
7	TIP PIN 9772-90	For 9772
8	REMOTE CONTROL SWITCH 9466	2 m (6.56 ft.)
9	TEMPERATURE PROBE 9451	
10	TEMPERATURE PROBE 9451-01	
11	0 ADJ BOARD Z5038	
12	FUSE SET Z5050	This contains 5 pieces
13	PROTECTOR Z5041	
14	CARRYING CASE C1014	

Measurement	Measurement parameters	Internal resistance measurement for batteries (AC four-terminal method) Terminal voltage measurement for batteries (DC voltage) Temperature measurement (when using the 9460)
	Resistance	3 mΩ (Max. display: 3.100 mΩ, Resolution: 1 μΩ) 30 mΩ (31.00 mΩ, 10 μΩ) 300 mΩ (310.0 mΩ, 100 μΩ) 3 Ω (3.100 Ω, 1 mΩ) Accuracy: ±0.8% rdg. ±6 dgt.
	Measurement Current	160 mA (3 mΩ, 30 mΩ range) 16 mA (300 mΩ range) 1.6 mA (3 Ω range)
	Measurement frequency	1 kHz ±30 Hz (with function for avoiding noise frequency enabled: 1 kHz ±80 Hz)
Other	Voltage	6.000 V, 60.00 V Accuracy: ±0.08% rdg. ±6 dgt.
	Temperature	-10.0°C to 60.0°C Accuracy: ±1.0°C
	Function	• Memory function (up to 6000 data) • Auto memory function • Auto-hold function • Measurement Navigator (When using Z3210, Gennect Cross: Voice guide output) • Tablet app (Gennect Cross) • PC app (Gennect One) • Comparator function (PASS/ WARNING/ FAIL) • Excel® Direct Input function (When using Z3210)
	Interfaces	USB2.0
	Operating temperature	0°C to 40°C, 80% RH or less (non-condensating)
	Storage temperature	-10°C to 50°C, 80% RH or less (non-condensating)
	Standards	EN61010 (Safety), EN61326 (EMC)
	Power supply	LR6 alkaline battery × 8
	Continuous operating time	8.5 hours
	Dimensions (W × H × D)	199 × 132 × 60.6 mm (7.83 × 5.20 × 2.39 in.)
Weight	960 g (33.8 oz.)	

The thresholds for determining the pass/fail condition of a battery depend on the specifications and standards of the battery manufacturer, battery type, capacity, etc. It is important and necessary to always conduct battery testing against the internal resistance and terminal voltage of a new or reference battery. In some cases, it may be difficult to determine the deterioration state of traditional open type (liquid) lead-acid or alkaline batteries, which demonstrate smaller changes in internal resistance than sealed lead acid batteries.

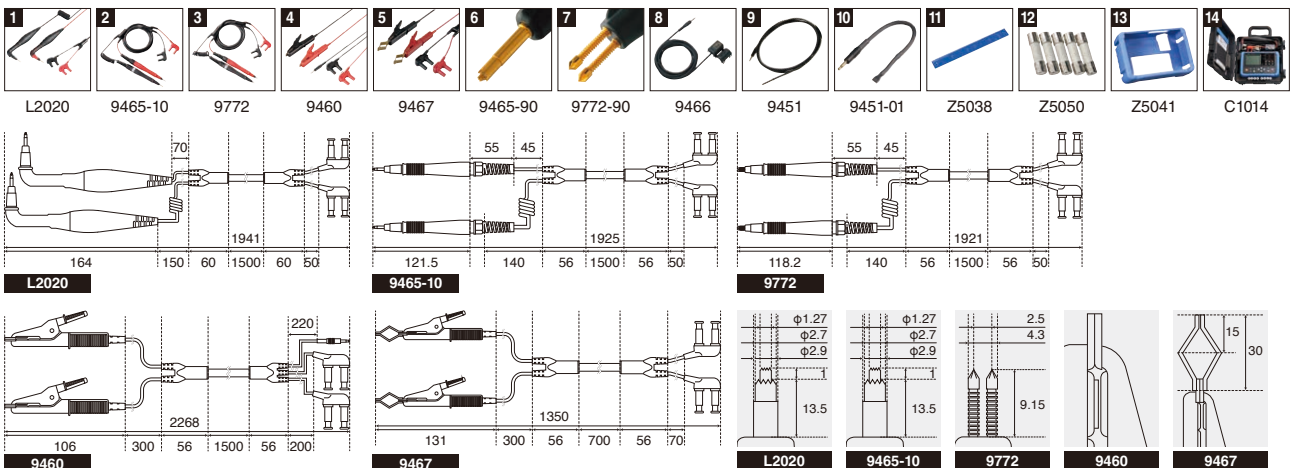

PV Maintenance

Inspect Solar Panel Bypass Diodes for Opens and Shorts

Improve testing efficiency by first inspecting the PV string, then testing individual modules for issues

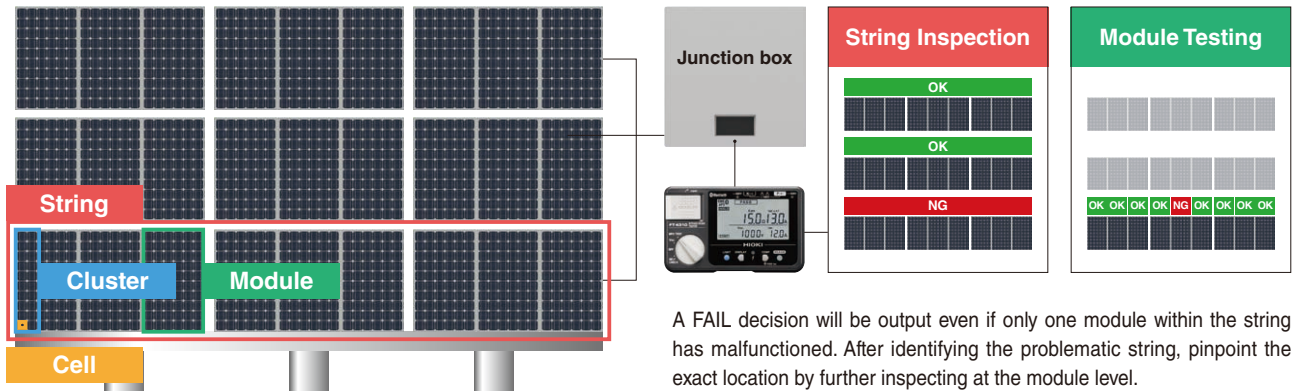

A FAIL decision will be output even if only one module within the string has malfunctioned. After identifying the problematic string, pinpoint the exact location by further inspecting at the module level.

- 1 RBPR: Bypass route resistance
- 2 Voc: Open-circuit voltage
- 3 Isc + α1: Measurement current
- 4 Isc: Short-circuit current

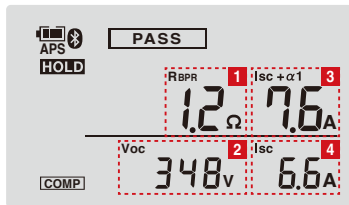

Normal reading

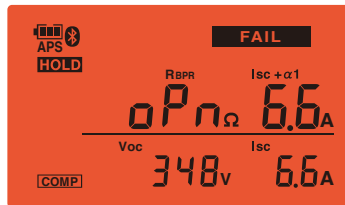

Open fault

Test open-circuit voltage, short-circuit current, and bypass route resistance at the same time

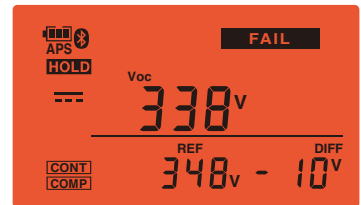

Short-circuit fault

Measure open-circuit voltage within 1 second and compare to reference value



Product warranty for 3 years
Accuracy guaranteed for 1 year

BYPASS DIODE TESTER FT4310

To be discontinued



Please see www.hioki.com for list of supported regions.



Gennect Cross

Order code **FT4310**

Included accessories



- TEST LEAD SET WITH REMOTE SWITCH L9788-11
- CARRYING CASE C0206
- Instruction manual
- Alkaline battery LR6 x6

L9788-11 C0206

Options	
1	TEST LEAD SET WITH REMOTE SWITCH L9788-11 1.2 m (3.94 ft.)
2	TEST LEAD WITH REMOTE SWITCH L9788-10 1.2 m (3.94 ft.)
3	TIP PIN L9788-90 For L9788, L9788-10
4	BREAKER PIN L9788-92 For checking breaker terminal
5	CARRYING CASE C0206

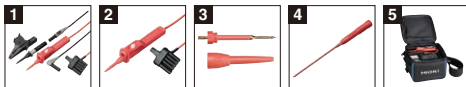

L9788-11 L9788-10 L9788-90 L9788-92 C0206

*For detailed information about L9788, please refer to p.27

BPD TEST mode (Bypass diode)	
Measurement items	Bypass diode comparator judgment Bypass route resistor Open-circuit voltage Short-circuit current Measurement (applied) current
Measurement object	Crystal system string Open-circuit voltage: 1000 V DC or less Rated current: 2 A to 12 A DC
Measurement method	Short-circuit and pulse voltage application
Duration of shorting between terminals	10 ms or less
Output pulse	Voltage: 100 V DC or less, Pulse width: 5 ms or less Limiting current: Measured short-circuit current + 1 A or less, Maximum: 13 A
Voc mode (open-circuit voltage)	
Measurement items	Open-circuit voltage
Measurement range	0 V to 1000 V DC (displayed up to 1200 V DC)
Response time	Within 1 sec.
Functions	Displays the number of bypass diode measurements Automatic polarity judgment function Comparison display Live circuit indicator Comparator Auto hold Backlight Auto power off Buzzer sounds Battery indicator
Operating temperature	-10°C to 65°C, 80% RH or less (non-condensating)
Storage temperature	-20°C to 65°C, 80% RH or less (non-condensating)
Dustproof and waterproof	IP40 (EN60529)
Standards	EN61010 (Safety), EN61326 ClassA (EMC)
Maximum input voltage	1000 V DC
Power supply	LR6 alkaline battery x 6
Continuous operating time	45 hours (Bluetooth® OFF)
Dimensions (W x H x D)	152 x 92 x 69 mm (5.98 x 3.62 x 2.72 in.), Cable length 0.5m (1.64 ft.)
Weight	650 g (22.9 oz.)

Clamp

Insulation

DiMMs

Detectors

Earth

Power quality

Power loggers

Battery

PV

Logger

LAN

Lux

Temperature

Resistance





COMPACT DATA LOGGERS

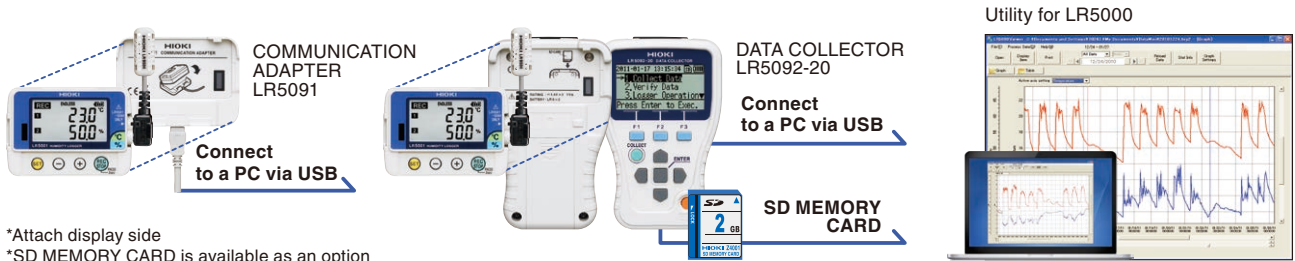

Collect Data with Portable Transfer Devices

Use the LR5091 or LR5092 to capture data and upload to the PC for analysis



*Attach display side
*SD MEMORY CARD is available as an option

Model	HUMIDITY LOGGER LR5001	TEMPERATURE LOGGER LR5011	INSTRUMENTATION LOGGER LR5031	CLAMP LOGGER LR5051
Log	Temperature, Humidity	Temperature	4-20 mA Instrumentation Signals	Load Current, Leak Current
Appearance				
Channels	1ch (temperature), 1ch (humidity)	1ch	1ch	2ch
Measurement range	-40.0°C to 85.0°C (temperature) 0% RH to 100% RH (humidity)	-40.0°C to 180.0°C ¹	-30.00 mA to 30.00 mA	0.00 A to 1000 A AC ¹
Accuracy	±0.5°C (temperature) ±5% RH (humidity)	±0.5°C	±0.5% rdg. ±5 dgt.	±0.5% rdg. ±5 dgt.
Bundled sensor	HUMIDITY SENSOR LR9504	Sensor sold separately	CONNECTION CABLE LR9801	Sensor sold separately

Model	VOLTAGE LOGGER LR5041	VOLTAGE LOGGER LR5042	VOLTAGE LOGGER LR5043
Log	Instrumentation signals, Analog outputs		
Appearance			
Channels	1ch	1ch	1ch
Measurement range	-50.00 mV to 50.00 mV	-5.000 V to 5.000 V	-50.00 V to 50.00 V
Accuracy	±0.5% rdg. ±5 dgt.	±0.5% rdg. ±5 dgt.	±0.5% rdg. ±5 dgt.
Bundled sensor	CONNECTION CABLE LR9802	CONNECTION CABLE LR9802	CONNECTION CABLE LR9802

LR5091 or LR5092-20 is necessary to transfer data from a LR5000 series logger to a PC



COMMUNICATION ADAPTER LR5091 (USB cable bundled)



DATA COLLECTOR LR5092-20 (USB cable bundled)

¹ Depends on current sensor in use

LR5000 Series Common Specifications

Measurement	Recording intervals	1/2/5/10/15/20/30 sec., 1/2/5/10/15/20/30/60 min.
	Recording modes	Instantaneous value, MAX/MIN/AVG
	Storage capacity	60,000 data sets per channel (instantaneous value)
Other	Operating temperature	LR5001, LR5011, LR5031, LR5041, LR5042, LR5043: -20°C to 70°C, 80% RH or less LR5051: 0°C to 50°C, 80% RH or less
	Power supply	LR6 alkaline battery x1 LR5051: LR6 alkaline battery x2
	Continuous operating time	LR5001: 3 months (1min. recording interval), 20 days (1sec.) LR5011: 2 years (1min. recording interval), 2 months (1sec.) LR5051: 1 years (1min. recording interval), 1 month (1sec.) LR5031, LR5041, LR5042, LR5043: 2 years (1min. recording interval), 2 months (1sec.)
	Dimensions (W x H x D)	79 x 57 x 28 mm (3.11 x 2.24 x 1.10 in.) LR5051: 79 x 70 x 37 mm (3.11 x 2.76 x 1.46 in.)
	Weight	105 g (3.7 oz.), LR5051: 165 g (5.8 oz.)

- Order code **LR5001** HUMIDITY SENSOR LR9504, Kickstand
- Order code **LR5011** Kickstand
- Order code **LR5031** CONNECTION CABLE LR9801, Kickstand
- Order code **LR5041** CONNECTION CABLE LR9802, Kickstand
- Order code **LR5042** CONNECTION CABLE LR9802, Kickstand
- Order code **LR5043** CONNECTION CABLE LR9802, Kickstand
- Order code **LR5051**

LR5000 Series Included accessories

- LR6 alkaline battery x 1 (LR5051: LR6 alkaline battery x 2)
- Instruction manual, Operation guide



Product warranty for 3 years
Accuracy guaranteed for 1 year

Make Logger Settings and Transfer Data via Bluetooth® Wireless Communication

Use your tablet or PC to download data and configure measurement conditions



Model	WIRELESS PULSE LOGGER LR8512	WIRELESS CLAMP LOGGER LR8513	WIRELESS HUMIDITY LOGGER LR8514	WIRELESS VOLTAGE/TEMP LOGGER LR8515
Log	Pulse	Load Current, Leak Current	Temperature, Humidity	DCV, Temperature
Appearance				
Channels	2ch	2ch	2ch (temperature), 2ch (humidity)	2ch
Measurement range	Pulse: 0 to 1000M pulse No. of revolutions: 0 to 5000/n ¹ [r/s]	500.0 mA to 5000 A AC ² 10.00 A to 2000 A DC ²	-40.0°C to 80.0°C (temperature) 0.0% rh to 100% RH (humidity)	Voltage: -50 V to 50 V Thermocouple (K): -200°C to 999.9°C Thermocouple (T): -200°C to 400°C
Accuracy	-	±0.5% rdg. ±5 dgt.	Temperature: ±0.5°C Humidity: ±3% RH ³	Voltage: ±0.05 mV Thermocouple: ±0.6°C
Bundled sensor	CONNECTION CABLE L1010	Sensor sold separately	Sensor sold separately	Sensor sold separately

¹n is the number of pulses, 1 to 1000, per revolution. ²Depends on current sensor in use ³Hysteresis: ±1% rh (added to the humidity measurement accuracy).

LR8512, LR8513, LR8514, LR8515 Common Specifications

Measurement	Other
Recording intervals	Recording modes
0.1 ¹ /0.2 ¹ /0.5/1/2/5/10/20/30 sec., 1/2/5/10/20/30/60 min.	Instantaneous value, MAX/MIN/AVG (LR8513 only)
Communication reaches	Storage capacity
30 m, line of sight	500,000 data sets per channel
Operating temperature	Power supply
-20°C to 60°C, 80% RH or less	LR6 alkaline battery × 2 AC ADAPTER Z2003 (option, DC12V)
Continuous operating time ²	Dimensions (W × H × D)
LR8512: 2 months (1min. recording interval), 2 months (1sec.) LR8513: 3 months (1min. recording interval), 1 month (1sec.) LR8514: 3.5 months (1min. recording interval), 3 months (1sec.) LR8515: 2.5 months (1min. recording interval), 10 days (1sec.)	LR8512, LR8514: 85 × 61 × 31 mm (3.35 × 2.40 × 1.22 in.) LR8513, LR8515: 85 × 75 × 38 mm (3.35 × 2.95 × 1.50 in.)
Weight	
LR8512, LR8514: 95 g (3.4 oz.), LR8513: 130 g (4.6 oz.), LR8515: 126 g (4.4 oz.)	

¹LR8512, LR8515 only ²With Bluetooth® communication OFF

- Order code **LR8512** CONNECTION CABLE L1010 × 2
- Order code **LR8513** -
- Order code **LR8514** -
- Order code **LR8515** -

- Included accessories for LR8512, LR8513, LR8514, LR8515**
- LR6 alkaline battery × 2
 - Measurement Guide, Caution for Using Radio Waves

Wireless Logger Collector (for collecting measurement data)	
Supported devices	Android tablet, Android smartphone Windows PC
OS	Android OS 4.0.3 or later Windows 11/10
Number of available registrations	Max. 100 units
Output format	Logger Utility format LR5000 format Smart Site compatible format CSV format Text format

How to obtain software
For Windows PC: download from the HIOKI website
For Android tablet: Google Play™

Use Logger Utility to view data acquired by the Wireless Logger Collector

Logger Utility

- Display waveform
- Analyze measurement data

Options



HUMIDITY LOGGER LR5001		
1	HUMIDITY SENSOR LR9501	1 m (3.28 ft.)
2	HUMIDITY SENSOR LR9502	5 m (16.4 ft.)
3	HUMIDITY SENSOR LR9503	10 m (32.81 ft.)
4	HUMIDITY SENSOR LR9504	4 cm (1.57 in.)
TEMPERATURE LOGGER LR5011		
5	TEMPERATURE SENSOR LR9601	Molded plastic type, 1 m (3.28 ft.)
6	TEMPERATURE SENSOR LR9602	Molded plastic type, 5 m (16.4 ft.)
7	TEMPERATURE SENSOR LR9603	Molded plastic type, 10 m (32.81 ft.)
8	TEMPERATURE SENSOR LR9604	Molded plastic type, 4.5 cm (1.77 in.)
9	TEMPERATURE SENSOR LR9611	Lug type, 1 m (3.28 ft.)
10	TEMPERATURE SENSOR LR9612	Lug type, 5 m (16.4 ft.)
11	TEMPERATURE SENSOR LR9613	Lug type, 10 m (32.81 ft.)
12	TEMPERATURE SENSOR LR9621	Sheathed type, 1 m (3.28 ft.)
13	TEMPERATURE SENSOR LR9631	Needle type, 1 m (3.28 ft.)
INSTRUMENTATION LOGGER LR5031		
14	CONNECTION CABLE LR9801	1 m (3.28 ft.), 2 wires
VOLTAGE LOGGER LR5041, LR5042, LR5043, PULSE LOGGER LR5061		
15	CONNECTION CABLE LR9802	1 m (3.28 ft.), 4 wires
LR5000 Series		
16	WALL-MOUNTED HOLDER LR9901	Cannot be used with LR5051
17	MAGNETIC STRAP Z5004	
DATA COLLECTOR LR5092		
18	SD MEMORY CARD 2GB Z4001	Use only SD Cards sold by HIOKI. Compatibility and performance are not guaranteed for PC cards made by other manufacturers.



WIRELESS PULSE LOGGER LR8512		
1	CONNECTION CABLE L1010	1.5 m (4.92 ft.)
WIRELESS HUMIDITY LOGGER LR8514		
2	HUMIDITY SENSOR Z2010	50 mm (1.97 in.)
3	HUMIDITY SENSOR Z2011	1.5 m (4.92 ft.)
WIRELESS LOGGER Series LR8512, LR8513, LR8514, LR8515		
4	AC ADAPTER Z2003	100 V to 240 V AC
5	MAGNETIC STRAP Z5004	
6	MAGNETIC STRAP Z5020	Extra strength



CURRENT SENSORS (For LR8513, LR5051)

Measurement application	For load current levels: Voltage output					
Model name	CLAMP ON SENSOR			AC FLEXIBLE CURRENT SENSOR		
Model	9669	9695-02	CT6500	CT9667-01	CT9667-02	CT9667-03
Appearance						
Rated measurement current	1000 A AC	50 A AC	500 A AC	5000/500 A AC	5000/500 A AC	5000/500 A AC
Output rate	0.5 mV/A	10 mV/A	1 mV/A AC	0.1 mV/A (5000 A) 1 mV/A (500 A)	0.1 mV/A (5000 A) 1 mV/A (500 A)	0.1 mV/A (5000 A) 1 mV/A (500 A)
Amplitude accuracy (DC, 45 to 66 Hz)	±1.0% rdg. ±0.01% f.s.	±0.3% rdg. ±0.02% f.s.	±1.5% rdg. ±0.03% f.s.	±2% rdg. ±0.3% f.s. ^{*1}	±2% rdg. ±0.3% f.s. ^{*1}	±2% rdg. ±0.3% f.s. ^{*1}
Max. rated voltage to earth	CAT III 600 V	CAT III 300 V	CAT III 600 V	CAT IV 600 V CAT III 1000 V	CAT IV 600 V CAT III 1000 V	CAT IV 600 V CAT III 100 V
Operating temperature	0°C to 50°C	0°C to 50°C	0°C to 50°C	-25°C to 65°C	-25°C to 65°C	-10°C to 50°C
Core jaw diameter	Φ55 mm or less 80 × 20 mm busbar	Φ15 mm or less	Φ46 mm or less	Φ100 mm or less	Φ180 mm or less	Φ254 mm or less

^{*1} At center of flexible loop
^{*2} Maximum measurable current when used with the LR8513, LR5051

Measurement application	For leak current: Voltage output	
Model name	CLAMP ON LEAK SENSOR	
Model	9657-10	9675
Appearance		
Rated measurement current	5 A AC ²	5 A AC ²
Output rate	100 mV/A	100 mV/A
Amplitude accuracy (DC, 45 to 66 Hz)	±1.0% rdg. ±0.05% f.s.	±1.0% rdg. ±0.005% f.s.
Max. rated voltage to earth	Insulated conductor	Insulated conductor
Operating temperature	0°C to 50°C	0°C to 50°C
Core jaw diameter	Φ40 mm or less	Φ30 mm or less

For CLAMP ON SENSOR 9695-02
CONNECTION CABLE 9219 For 9695, 3 m (9.84 ft.)

9219
The following sensors can be used with Model LR8513 via the DISPLAY UNIT CM7290 (requires OUTPUT CORD L9095)

AC/DC CURRENT SENSOR CT7631	Φ33 mm, 100 A
AC/DC CURRENT SENSOR CT7636	Φ33 mm, 200 A*
AC/DC CURRENT SENSOR CT7642	Φ55 mm, 2000 A
AC/DC AUTO-ZERO CURRENT SENSOR CT7731	Φ33 mm, 100 A
AC/DC AUTO-ZERO CURRENT SENSOR CT7736	Φ33 mm, 200 A*
AC/DC AUTO-ZERO CURRENT SENSOR CT7742	Φ55 mm, 2000 A
AC FLEXIBLE CURRENT SENSOR CT7044	Φ100 mm, 5000 A*
AC FLEXIBLE CURRENT SENSOR CT7045	Φ180 mm, 5000 A*
AC FLEXIBLE CURRENT SENSOR CT7046	Φ254 mm, 5000 A*

* Maximum measurable current when used with the LR8513.
For more details, please refer to our website.

- Clamp
- Insulation
- DIEMS
- Detectors
- Earth
- Power quality
- Power loggers
- Battery
- PV
- Logger
- LAN
- Lux
- Temperature
- Resistance

LAN Cable Testers



LAN CABLE HiTESTER 3665

Product warranty for 3 years
Accuracy guaranteed for 1 year



Included accessories

- TERMINATOR 9690 (ID 0)
- Carrying case
- LR6 alkaline battery × 2
- Instruction manual

PASS	ID 0
SH	
Straight Cable	
20.1m	

Display wire map, cable length, and ID of connected terminal

FAIL	ID 0
12 45 36 78	SH
11 11 11 11	
12 36 45 78	
20.1m	

Pins 3 and 6 have been incorrectly paired with Pins 4 and 5

Order code **3665**

Options		
1	TERMINATOR 9690-01	ID 1 to 5
2	TERMINATOR 9690-02	ID 6 to 10
3	TERMINATOR 9690-03	ID 11 to 15
4	TERMINATOR 9690-04	ID 16 to 20
5	CARRYING CASE 9249	



9690-01
9690-02
9690-03
9690-04

9249

Measurement		
Measurable cable	Twisted-pair cable, characteristic impedance: 100 Ω, shielded and unshielded, CAT 3, 4, 5, 5e, 6 and 6A *Not available for CAT 7	
Compatible connectors	RJ-45 plugs	
Wire Map test (detectable errors)	Open, short, reversed, transposed, split pairs and other incorrect wiring	
Measurement parameters	Cable length	2.0 to 300.0 m Accuracy: ±4% rdg. ±1 m (in case of single line)
	Direction	Up to 21 cables can be identified ¹⁾
Functions	Backlight, auto power off	
Operating temperature	0°C to 40°C, 80% rh or less (non-condensating)	
Storage temperature	-10°C to 50°C, 80% rh or less (non-condensating)	
Standards	EN61010 (Safety), EN61326 (EMC)	
Other	Power supply	LR6 alkaline battery × 2
	Continuous operating time	50 hours
	Dimensions (W × H × D)	85 × 130 × 33 mm (3.35 × 5.12 × 1.30 in.)
Mass	160 g (5.6 oz.)	

¹⁾Using the supplied Terminator 9690 and optional Models 9690-01 to 9690-04

Clamp

Insulation

DIMMS

Detectors

Earth

Power quality

Power loggers

Battery

PV

Logger

LAN

Lux

Temperature

Resistance

Lux Testers

LUX METER FT3424, FT3425



Product warranty for 3 years
Accuracy guaranteed for 2 years



FT3424

FT3425



Extension cart minimizes physical stress



- Built-in Bluetooth® wireless technology
- Verify and record measured data with free Gennect Cross mobile app
- *Available only with products displayed with the Gennect Cross icon



Please see www.hioki.com for list of supported regions.



Gennect Cross

Order code **FT3424**

Order code **FT3425**

Measurement	Standards	DIN 5032-7: 1985 Class B, JIS C 1609-1: 2006 General Class AA
	Light receiving element	Silicon photo-diode
	Measurement ranges	20.00 lx, 200.0 lx, 2000 lx, 20000 lx, 200000 lx
	Linearity	±2% rdg. ¹
	D/A output	Output level: 2 V/range f.s. Output accuracy: ±1% rdg. ±5 mV (at output rate)
Other	Functions	Timer hold function, memory function (up to 99 measured data can be saved.), hold, auto power off, buzzer sound, backlight, zero adjustment
	Interfaces	USB2.0 (FT3425 only: Bluetooth® 4.0LE)
	Operating temperature	-10°C to 40°C, 80% RH or less (non-condensating)
	Storage temperature	-20°C to 50°C, 80% RH or less (non-condensating)
	Accuracy guarantee for temperature and humidity	21°C to 27°C, 75% RH or less (non-condensating)
	Dustproof and waterproof	IP40 (EN60529)
	Standards	EN61010 (Safety), EN61326 (EMC), JIS C 1609-1: 2006 General Class AA, DIN 5032-7: 1985 Class B
	Power supply	LR6 alkaline battery × 2, or USB bus power (5 V DC)
	Continuous operating time	300 hours (Bluetooth® communication OFF)
	Dimensions (W × H × D)	78 × 170 × 39 mm (3.07 × 6.69 × 1.54 in.)
Weight	FT3424: 310 g (10.9 oz.), FT3425: 320 g (11.3 oz.)	

¹Multiply by 1.5 for display values in excess of 3000 lx.

Included accessories

- CARRYING CASE
- LR6 alkaline battery × 2
- Sensor cap (with strap)
- Strap
- USB cable (0.9 m)
- Instruction manual
- Precautions concerning use of equipment that emits radio waves (only FT3425)

Options

1	EXTENSION CART Z5023	
2	CONNECTION CABLE L9820	
3	CARRYING CASE C0202	Soft case
4	CARRYING CASE C0201	Semi-hard case
5	OUTPUT CORD L9094	Mini plug to banana 1.5 m (4.92 ft.)
6	OUTPUT CORD L9095	Connect to BNC terminal 1.5 m (4.92 ft.)
7	OUTPUT CORD L9096	Connect to terminal block 1.5 m (4.92 ft.)



Temperature Testers

INFRARED THERMOMETER FT3700-20, FT3701-20



Product warranty for 1 year
Accuracy guaranteed for 1 year



FT3700

FT3701

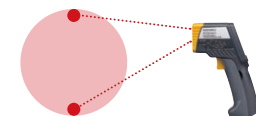

Measure the average temperature inside a circle whose diameter is defined by the two indicated points.

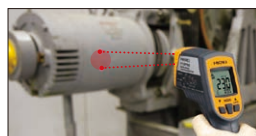

Measure areas that cannot be touched or unreachable locations due to moving parts

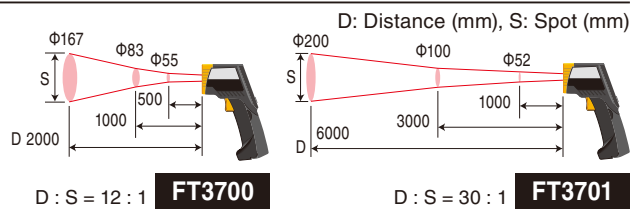

Included accessories

- CARRYING CASE
- LR03 alkaline battery × 2
- Instruction manual

Order code **FT3700-20**

Order code **FT3701-20**

Measurement	Measurement range	FT3700: -60.0 to 550.0°C (-76 to 1022°F) ¹ FT3701: -60.0 to 760.0°C (-76 to 1400°F) ¹
	Accuracy	0.0 to 100.0°C (-32.0 to 212.0°F): ±2°C 100.1 to 500.0°C (212.1 to 932.0°F): ±2% rdg. -35.0 to -0.1°C (-31.0 to 31.9°F): ±10% rdg. ±2°C ²
	Measurement field diameter	FT3700: Φ83 mm at 1000 mm FT3701: Φ100 mm at 3000 mm
	Functions	MAX/MIN/DIF (MAX-MIN)/AVG measurement, alarm, backlight, continuous measurement mode, auto power off
Other	Operating temperature	0°C to 50°C, 80% RH or less (non-condensating)
	Storage temperature	-10°C to 50°C, 80% RH or less (non-condensating) 50°C to 60°C, 70% RH or less (non-condensating)
	Accuracy guarantee for temperature and humidity	23°C ±3°C, 80% RH or less (non-condensating)
	Standards	IEC 60825-1 CLASS2 (Laser), EN61326 (EMC)
	Power supply	LR03 alkaline battery × 2
Continuous operating time	140 hours	
Dimensions (W × H × D)	48 × 172 × 119 mm (1.89 × 6.77 × 4.69 in.)	
Weight	256 g (9.0 oz.)	

¹Guaranteed accuracy range is -35 to 500°C.

²-60.0 to -35.1°C (-76.0 to -31.1°F): Accuracy not specified

Resistance meter

RESISTANCE METER RM3548-50



Product warranty for 3 years
Accuracy guaranteed for 1 year



The RM3548-50 offers effortless operation and accuracy, making it ideal for EV maintenance, aircraft overhaul, and motor inspections.



Bluetooth® communication enables seamless data integration with mobile apps or Excel®, speeding up data sharing and report creation.

With Z3210

Bluetooth®
Please see www.hioki.com for list of supported regions.

Gennect Cross

Z3210

Included accessories

- Clip Type Lead L2107
- Temperature Sensor Z2002
- Protector Z5041
- LR6 alkaline battery × 8
- Instruction manual
- USB cable (A to mini-B)
- Strap
- Spare fuse

Order code **RM3548-50**

Order code **Z3210**

Options

1	TEST LEADS L2140	
2	PIN TYPE LEAD L2141	
3	PIN TYPE LEAD L2142	
4	PIN TYPE LEAD 9465-10	
5	PIN TYPE LEAD 9465-11	
6	PIN TYPE LEAD 9772	
7	FOUR TERMINAL LEAD 9453	
8	LARGE CLIP TYPE LEAD 9467	tip φ 28 mm (1.10 in.)
9	CLIP TYPE LEADS L2107	
10	TIP PIN 9465-90	To replace the tip on the 9465-10, 9465-11, L2140 (one piece)
11	PIN TYPE LEAD 9772-90	To replace the tip on the 9772 (one pin)
12	TEST LEAD (RED) L2140-01	L2140 red lead
13	TEST LEAD (BLACK) L2140-02	L2140 black lead
14	TEMPERATURE SENSOR Z2002	100 mm (3.94 in.)
15	LED COMPARATOR ATTACHMENT L2105	2 m (78.74 in.)
16	ZERO ADJUSTMENT BOARD 9454	For 9465-10 and 9465-11
17	0 ADJ BOARD Z5038	For 9465-10, and 9772
18	PROTECTOR Z5041	
19	CARRYING CASE C1015	Hard case

Measurement parameters	Resistance measurement, temperature measurement
Measurement method	Resistance: DC four-terminal method, Temperature: thermistor
Resistance range	3 mΩ (3.5000 mΩ display max., 0.1 μΩ resolution) to 3 MΩ range (3.5000 MΩ display max., 100 Ω resolution), 10 steps Measurement accuracy: ±0.020 % rdg. ±0.007 % f.s.
Temperature measurement	-10.0°C to 99.9°C, accuracy: ±0.5°C (temperature Sensor Z2002 and RM3548-50 combined accuracy)
Operating temperature and humidity range	0°C to 40°C (32°F to 104°F), 80% RH or less (non-condensing)
Storage temperature and humidity range	-10°C to 50°C (14°F to 122°F), 80% RH or less (non-condensing)
Applicable standards	EN61010 (safety), EN61326 (EMC)
Circuit protection	The circuit is protected until 42.4 V peak AC, 60 V DC is reached
Memory storage	Number of recordable data points: up to 1,000 for manual/auto, up to 6,000 for interval; interval: 0.2 s to 10.0 s (0.2 s step); acquisition of data from memory: display, USB mass storage (CSV, TXT files)
Communication functions	USB, wireless communications via Bluetooth® (Z3210 is necessary)
Power supply	LR6 alkaline battery × 8 or HR6 nickel-metal hydride battery × 8
Maximum rated voltage	5 VA
Continuous operating time	Approx. 10 hours (when eight fresh LR6 alkaline batteries or eight HR6 nickel-metal hydride batteries are used)
Dimensions (W × H × D)	199 × 132 × 60.6 mm (7.83 × 5.20 × 2.39 in.)
Weight	890 g (31.4 oz.)



Measurement Lead Selection Guide
For detailed dimensions, features, and measurement target information, please refer here.



Product Warranties Hioki products are generally covered by a three-year warranty.

Product warranty	In the event Hioki is responsible for the failure of a product during the warranty term beginning on the date of purchase (or beginning in the month the product was manufactured if the date of purchase is unclear), we will repair or replace the product free of charge.
Warranty scope	We check products on a standalone basis to verify their specifications, performance, and functionality. Although we verify proper operation of components that are connected to Hioki products in standard configurations, we ask that customers verify proper operation of their Hioki products when connected to other manufacturers' products. The scope of Hioki's warranty is limited to Hioki products. Connected devices and issues caused by connected devices are considered outside the scope of the warranty. In the event of physical damage, any compensation that might be provided by Hioki is limited to the purchase price of the product.
Accuracy guarantee	For products with an accuracy guarantee, we guarantee the level of accuracy indicated in the specifications for a certain period of time following shipment from the factory. In the event of an accuracy defect during that period of time, we will adjust the product free of charge.

After-sales Service

Standard Calibration	<p>If measured values fail to meet Hioki's standards during a calibration performed by Hioki ("Standard Calibration"), the instrument will be adjusted to meet the standards, and the calibration will then be repeated.</p> <p>For supported products, please refer to the "Service Information by Product" section on our website.</p> <p>Except for certain products, the company recommends that each product's accuracy guarantee period be treated as the recommended calibration interval.</p> <p>If a customer reports a loss of accuracy after Standard Calibration while the instrument in question is covered by the recommended calibration interval and we are able to verify the issue, we will adjust the instrument free of charge.</p>
ISO/IEC 17025 Calibration (JCSS)	<p>After Standard Calibration, we perform calibration based on ISO/IEC 17025.</p> <p>Hioki Headquarters is an international MRA-compliant, JCSS-accredited calibration service provider that meets ISO/IEC 17025 requirements. A JCSS calibration certificate bearing the JCSS symbol, compliant with the international MRA framework, is issued as internationally recognized proof of calibration.</p> <p>For details about which products are eligible for this service, please contact us. Note that the service is limited to the JCSS-accredited field of calibration. You can check the JCSS-accredited field of calibration on our website under Service for Calibration and Adjustment > ISO/IEC 17025 Calibration (JCSS) > JCSS certificate and scope of accreditation(English).</p>
Repair	<p>All faults reported by the customer will be repaired. Standard calibration is first conducted as a pre-repair diagnostic procedure, followed by standard calibration or adjustment/calibration after the repair. In some cases, pre-repair calibration may not be possible depending on the type of repair required.</p> <p>For supported products, please refer to the "Service Information by Product" section on our website.</p> <p>If within six months of the original repair, Hioki is responsible for an issue requiring an additional repair (a repair of the same issue) of a product that has been used as described in its user manual. We will repair it free of charge.</p>

Warranty coverage after each service does not apply to issues suspected to be caused by factors such as component lifespan and degradation, equipment damage, or problems related to usage or storage conditions.
 The calibration validity period (calibration interval) should be determined by each customer, taking into account the calibration interval recommended by the company.

Quality of Hioki's calibration and repair service

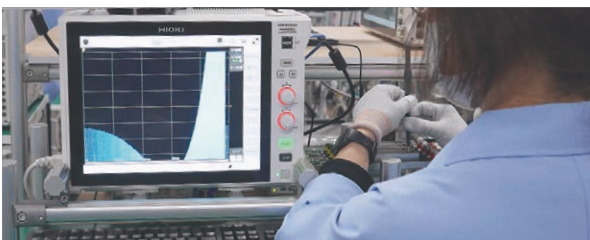

90 years of history and fine-grained, expert service
 Technicians performing calibration, adjustment, and repair work undergo in-house training to ensure they possess the specialized expertise and skills that such work demands.

Precise calibration and adjustment guidelines compiled by product designers
 We determine everything from the procedures for measuring instrument functionality checks to calibration points based on the results of reviews conducted by designers who are well versed in the characteristics of products' internal circuitry and the principles that underlie their operation. In this way, we are able to provide optimal, extensive calibration and adjustment service as only the manufacturer can.

Highly reliable service that's traceable to national standards
 The standard devices we use to calibrate and adjust products are all linked to national standards, ensuring that we can issue inspection reports with accurate, reliable calibrated values.

Comprehensive calibration and repair service with fast turnaround
 If we discover a malfunction or failure during the calibration process, we'll contact you to let you know where the problem is and what's necessary to address it. If you wish, we'll then repair the product. This capability eliminates unnecessary back-and-forth so you can put your product back to work as soon as possible.

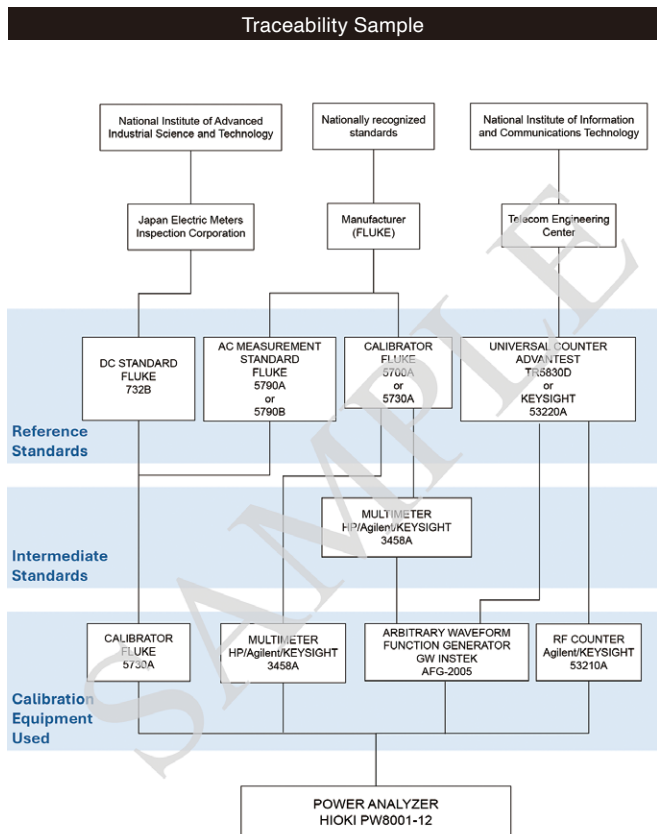

Calibration and Repair Service

(1) Service content

"Calibration Services"

When an instrument is calibrated and its measured values are found not to satisfy internal Hioki standards, the instrument is adjusted. Through the ongoing use of calibration services offered as only an instrument manufacturer can, customers are able to use their instruments with peace of mind while maintaining their precision.

This calibration service will allow us to return products to customers with minimal downtime, since there are no work interruptions.

Notes

*If you do not wish your instrument to be adjusted, please let us know when you request calibration. Your product will be returned without adjustment, even if the calibration report indicates a FAIL judgment (non-compliance).

*This service does not extend to products that cannot be adjusted or to discontinued products.

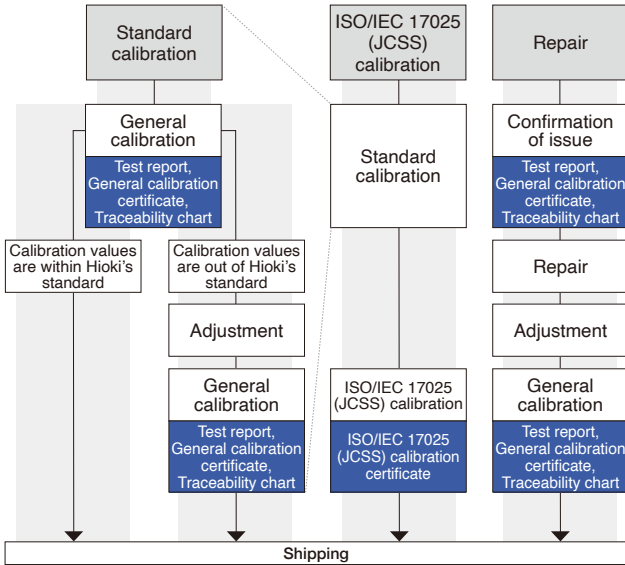

Depending on the type of repair, standard calibration may not be possible in advance.

(2) Documents we can issue and their content

Sample documents are also available on Hioki's website.



Test report

- Calibration results
- Judgment



General calibration certificate

- Calibration certificate declaration
- Information about equipment used in calibration

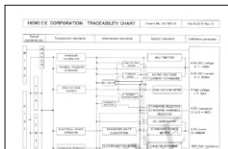

Traceability chart (overall)

An overview tracing Hioki product groups to national standards via individual standard devices

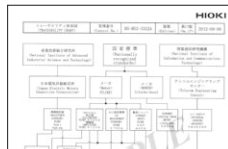

Traceability chart (model-specific)

A detailed diagram tracing a particular product model to national standards via individual standard devices



JCSS calibration certificate

- Calibration results
- Inaccuracies
- Coverage factor
- Calibration certificate declaration
- ilac-MRA, IA Japan, and JCSS logos

Calibration

Calibration provides a way to check the condition of a measuring instrument by comparing the ideal value indicated by a standard device with the value indicated by the instrument being calibrated.

Adjustment

Calibration values will be optimized so that the instrument satisfies Hioki's internal standards.

If an instrument is adjusted as part of calibration service

Values are optimized so that they satisfy Hioki's internal standards to reduce the risk that they will subsequently exceed the tolerance.

Adjustment is performed since the tolerance is anticipated to be exceeded during the next calibration.

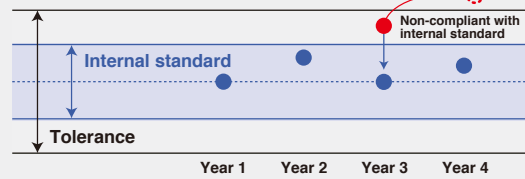

ISO/IEC 17025 Calibration (JCSS)

When is JCSS necessary?

JCSS calibration is the solution when you need calibration that includes inaccuracy data, for example ISO/IEC 17025 calibration, ILAC calibration, MRA calibration, or IATF 16949 calibration.

Specific examples:

- Calibration of instruments used by automobile (or motorcycle) manufacturers and part suppliers
- Calibration of instruments used in UL product certification
- Calibration of instruments as required by Japanese law (for radiation therapy) or ministerial ordinance (for pharmaceuticals and quasi-drugs)

JCSS calibration and international MRAs

JCSS is a registration program designed to ensure that calibration service providers possess the technological skills needed to perform calibration that complies with measurement-related laws and the requirements imposed by ISO/IEC 17025.

Registered service providers are entitled to perform JCSS calibration and issue calibration certificates bearing the JCSS symbol mark. Such certificates serve as evidence of the calibration service provider's technological skills and traceability. JCSS calibration service providers who have been certified as international MRA-compliant can issue calibration certificates bearing the ILAC-MRA and IA Japan symbol marks. Such certificates can be used as official documents whose validity is recognized worldwide.

International MRAs

An MRA is a mutual recognition agreement. IA Japan belongs to ILAC and APAC which includes NVLAP, A2LA, UKAS, DAkkS, and NATA. Calibration certificates issued by calibration service providers that have been certified as MRA-compliant by IA Japan are treated as equivalent to calibration certificates recognized by member certification entities in member countries.

Service capability and warranty duration

You can find out whether Hioki accepts repair and calibration requests for your instrument, associated lead times if so, and the information listed below simply by entering the product model number on Hioki's website.

The screenshot shows a search for product '01222'. The results table is as follows:

Model	Product	Available Services	Discontinued date
01222	DIGITAL MULTIMETER	Calibration Repair	✓
Recommended calibration interval	18 months		
Product production period	30 months		

Summary information on the right:

- Availability of repair and calibration service: Available
- Calibration Interval: 18 months
- Product warranty period: 30 months
- Date production discontinued: 30 months

Sales and service network

● HQ ● Regional Group HQ ● Offices of Group Companies

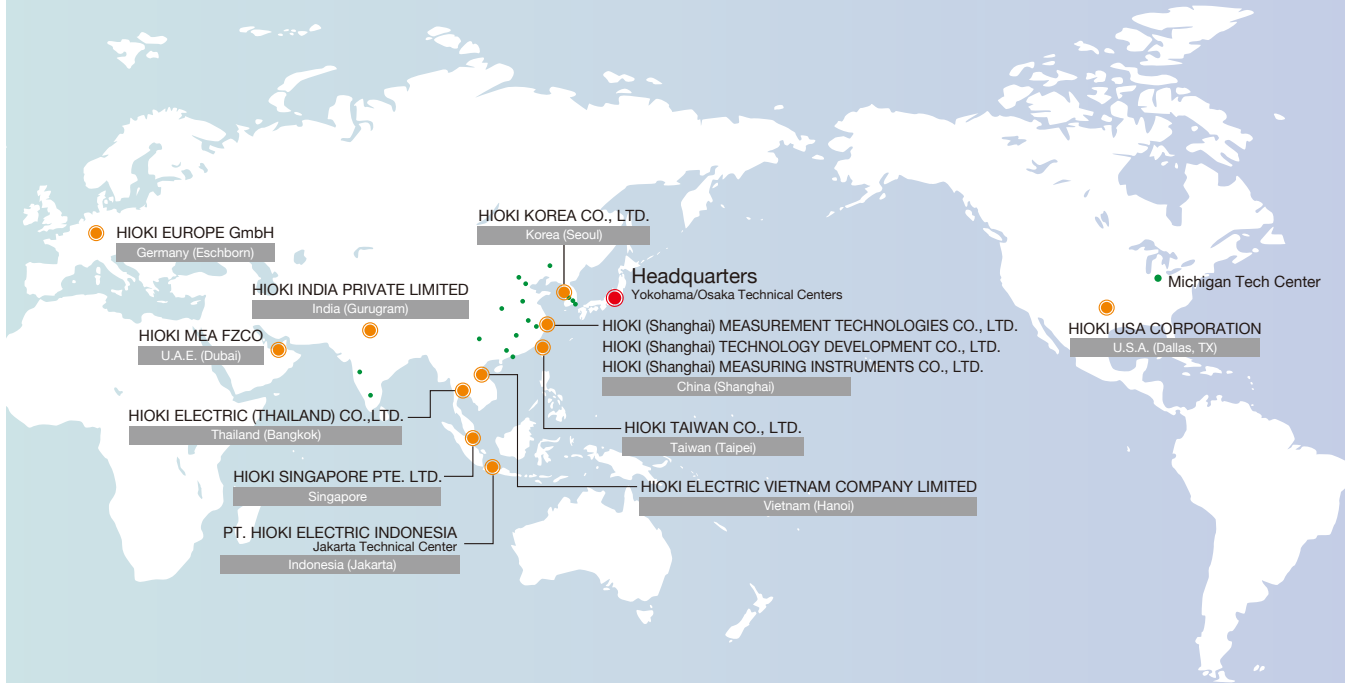

Our knowledgeable staff are always happy to assist you at Hioki group offices. Feel free to contact local tech centers or sales offices if you have any questions or need support.

What we offer:

- Expert consultation to help enhance your measurement accuracy
- Product training tailored to your specific applications
- Hands-on measurement of your Devices Under Test (DUTs)
- Integrated use of our measuring instruments for advanced applications

*The Bluetooth® word mark and logos are registered trademarks owned by Bluetooth SIG, Inc. and any use of such marks by HIOKI E.E. CORPORATION is under license. Note: company names and product names appearing in this brochure are trademarks or registered trademarks of various companies.

HIOKI
HIOKI E. E. CORPORATION

81 Koizumi,
Ueda, Nagano 386-1192 Japan
<https://www.hioki.com/>



Scan for all regional contact information

DISTRIBUTED BY



CALPLUS
Die Kompetenz in der Messtechnik

CalPlus GmbH - Zentrale
Heerstraße 32
14052 Berlin
Tel.: 030 214982-0
Fax: 030 214982-50
office@calplus.de
www.calplus.de

CalPlus GmbH
Normannenweg 30
20537 Hamburg
Tel.: 040 3039595-0
Fax: 040 3039595-50
scopeshop@calplus.de
www.calplus.de