

# HIOKI

## INSULATION / WITHSTANDING Test Instrument series 3153, 3159, 3174, ST5520



3153 CE



3174 CE



3159 Not CE Marked



ST5520 CE

This electrical safety test instrument series is designed for insulation resistance and voltage withstand testing of electrical devices and components according to various safety standards. A multitude of automation and labor-saving features are provided to ensure effective testing for a wide variety of requirements and test conditions. Select the most appropriate model for your applications.

AUTOMATIC INSULATION / WITHSTANDING HI-TESTER 3153  
INSULATION / WITHSTANDING HI-TESTER 3159  
AC AUTOMATIC INSULATION/WITHSTANDING HI-TESTER 3174  
INSULATION TESTER ST5520

**3** year  
Warranty

## Model 3153

# Automatic Insulation Voltage Withstand Testing

### Voltage Control from a PC

#### Full Remote Control

All test parameters can be controlled by RS-232C or GP-IB, including test voltage, cut-off current, resistance threshold and timer durations. Start-stop control can be provided with the 9613 single hand remote control or 9614 two-hand remote control.

### Standards-Based Testing

#### Comparator/Timer

Includes built-in pass-fail comparator and timer functions for easy compliance testing to various safety standards such as those for Electrical Appliance Safety Regulations.

### Settable Ramp Up/Down Test Voltage Timing

#### Ramp Timer Functions

Raising and lowering of test voltage can be set for voltage withstand testing.

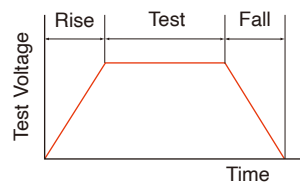

### Test Status Read/Write

#### Program Function

Test conditions can be stored and recalled to support complete automation by sequencer. Up to 32 files can be stored with up to 50 steps per file.

Up to 32 files

#### Analog Voltmeter

The test voltage can be verified not only on the digital display but also on the analog meter.

#### Danger Lamp

The warning light flashes during testing and whenever high voltage is present at the terminals.

#### External Switch

Start/stop may be controlled with the 9613 or the 9614. (The 9613 and 9614 are options.)

#### Fluorescent Display Tube

The display uses a bright, easy-to-read fluorescent tube.

#### Test Mode Selection

Three test modes are selectable:

1. Manual test modes: ACW, DCW, I
2. Automatic test modes: W → I, I → W
3. Programmed test modes: testing by preprogrammed functions.

#### ● Automation Support

Automation features include programmable testing modes, EXT I/O, RS-232C, GP-IB, connection scanning and various data management functions.

#### ● Save 10 Sets of Test Conditions

Store up to 10 sets of test conditions for voltage withstand and insulation resistance modes, so you can quickly switch among the test conditions. (Save/Load)

#### ● Interlock Protect Function

To ensure safety during automatic testing, test output can be interrupted and testing inhibited by input signals from automatic sensing devices.

#### ● Auto Discharge Feature

Any charge on the object under test is discharged by the test instrument, so there is no residual charge after testing. (DC voltage withstand, insulation resistance tests)

#### ● Zero-V Switching

Test voltage on/off switching can be forced to occur only at sine wave zero-crossings. (AC voltage withstand testing)

#### ● PWM Switching Technique

Enhanced accuracy is obtained by preventing variations in supply voltage from affecting test voltage.



## Wide Range of Functions for Various Conditions

### 1. Pass Hold Function (0: No Hold, 1: Hold)

The pass state is held when it is activated. This is convenient for verifying the decision value.

### 2. Fail Hold Function (0: No Hold, 1: Hold)

The fail state is held when it is activated. This is convenient for temporarily stopping the test process.

### 3. Hold State (0: No Hold, 1: Hold)

This saves the state when the Stop key is pressed during a test to unconditionally end the test.

### 4. Momentary Out (0: Disabled, 1: Enabled)

This function outputs a voltage only when the Start key is being pressed. The Start key is effective both for EXT SW and external I/O.

### 5. Double Action (0: Disabled, 1: Enabled)

This function allows testing to start only if the Start key is pressed within a half second after the Stop key.

### 6. Fail Mode (0: Disabled, 1: Enabled)

This function allows the Hold state to be released only by the Stop key on the instrument panel.

### 7. "START" Interface Command (0: Disabled, 1: Enabled)

This specifies whether the "START" command is enabled.

### 8. Interlock Function (0: Disabled, 1: Enabled)

This specifies whether the interlock terminal for external I/O is enabled.

### 9. Maximum Output Voltage

Sets the upper limit of the test voltage.

### 10. Insulation Resistance Measurement Range

(0: Fixed Range, 1: Automatic Range)

This specifies whether the measurement range for insulation resistance testing should be fixed or automatically determined.

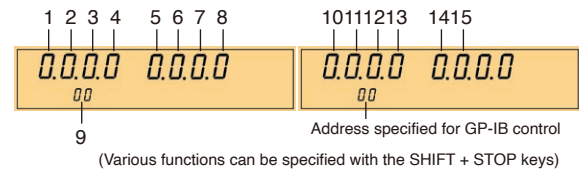

### 11. Insulation Resistance Test End Mode

0: Test for the specified time

1: Stop when "pass" is detected

2: Stop when "fail" is detected

This specifies the method of ending insulation resistance tests.

### 12. Ramp Time Setting

0: No judgment during ramp-up

1: Judgment during ramp-up

This specifies whether the judgment is enabled during ramp-up. Valid only during voltage withstand testing.

### 13. PC Interface

0: RS-232C (PC, 9600 bps)

1: RS-232C (PC, 19200 bps)

2: GP-IB

This specifies the type of PC interface to use.

### 14. Electrical Discharge Function

(0: Disabled, 1: Enabled)

This specifies whether the electrical discharge function is enabled at the end of testing.

### 15. Test Signal Output

0: ON also when TEST indicator is flashing

1: OFF when TEST indicator is flashing

2: ON only when TEST indicator is flashing

(excluding ramp down time)

This specifies whether the TEST signal of the external I/O should be output when the TEST indicator is flashing.

## Enhanced System Measurements

### Maximum 32-Channel Multi-Point Testing

#### Model 3930 HIGH VOLTAGE SCANNER

Combine Model 3153 with the HIGH VOLTAGE SCANNER 3390 to perform insulation withstand testing easily. Single-end inputs test up to 8 points (between any 4 points) per instrument, and can connect up to 4 instruments together.

#### ■ Model 3390 Basic Specifications

|   |  |
|---|--|
| Operation modes                           | Multi-mode: Scanning of user-selected points for high 4 ch / low 4 ch<br>Single mode: Common scan of high 8 ch - common                            |
| Rated voltage used                        | 5 kV AC / 5 kV DC  |
| Operation indications                     | Lamps light up when power is supplied and when a specified channel is operating  |
| [Relay area]                              |  |
| Max. open and closed voltage              | 5000 V DC, 5000 V AC   |
| Max. open and closed current              | 1.0 A (open and closed capacity: 50 W)   |
| Contact point indirect contact resistance | 500 mΩ or less, with 1 mA AC   |
| Contact point max. capacity               | 50 W   |
| Time                                      | Operation time: 6 ms or less, Recovery time: 6 ms or less  |
| Power supply                              | VSCV 24 V DC, ±10% (applied using the control signal input connector), 12 VA max.  |
| Dimensions and mass                       | 316 mm (12.44 in)W × 100 mm (3.94 in)H × 350 mm (13.78 in)D, 4.2 kg (148.1 oz)   |
| Accessories                               | Control input connector connection cable ×1, H.V. Test lead 9615-01 (red) ×8, H.V. Test lead (black) ×1, Grounding cable ×1, Instruction manual ×1 |

### Simultaneous Protective Ground Continuity Testing

#### Safety Inspection System

Combine Model 3153 with the AC GROUNDING HiTESTER 3157-01 and a general-purpose sequencer for a simple safety test inspection system that includes protective ground continuity and insulation withstand testing.



Model 3157-01  
AC GROUNDING HiTESTER

Settable current ranges:  
3.0 to 31 A AC

Max. output power:  
130VA

Resistance  
measurement range:  
0 to 1,800 Ω

# A Full Line-up of Models to Suit Various Needs

## Model 3153

AUTOMATIC INSULATION / WITHSTANDING HITESTER



GP-IB

RS-232C

- Insulation and AC/DC continuous voltage withstand testing
- Safety standards compliance testing
- Stores up to 10 sets of test conditions (10 each for insulation and voltage withstand)
- Zero-V Switching (voltage withstand testing)
- Electrical Discharge function (DC voltage withstand, insulation testing)
- Automated testing support
- Interlock Protect function
- Remote controllable

**Voltage Withstand Testing**  
 AC: 0.20 to 5.00 kV, 500 VA  
 DC: 0.20 to 5.00 kV, 50 VA  
 0.01 to 100.0 mA

**Insulation Testing**  
 DC: 50 to 1200 V  
 0.10 to 9999 MΩ

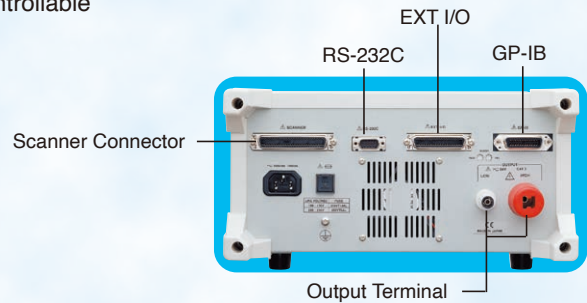

## Model 3159

INSULATION / WITHSTANDING HITESTER



RS-232C

- Insulation and voltage withstand testing
- Safety standards compliance testing
- Stores up to 10 sets of test conditions (10 each for insulation and voltage withstand)
- Voltage comparator functions (voltage withstand testing)
- Zero-V Switching (voltage withstand testing)
- Electrical Discharge function (insulation testing)
- Automated testing support
- Interlock Protect function
- Remote controllable
- Not CE marked

**Voltage Withstand Testing**  
 AC: 0 to 2.5 kV/5.0 kV, 500 VA  
 0.01 to 120.0 mA

**Insulation Testing**  
 DC: 500/1000 V  
 0.5 to 2000 MΩ

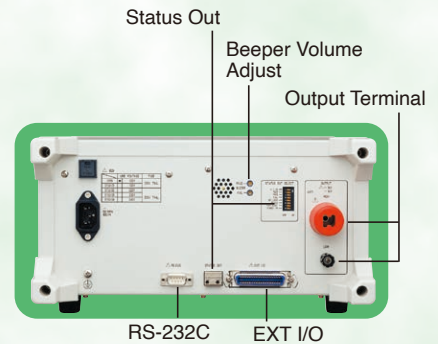

## Model 3174

AC AUTOMATIC INSULATION/WITHSTANDING HITESTER



RS-232C

- Continuous testing of insulation (500/1000 V) and withstand voltage (100 VA transformer capacity)
- Full remote operation when used in combination with the Safety Test Data Management Software 9267
- Save up to 8 test settings each for the withstanding and insulation testing modes
- Precise test voltage without power voltage dependency is generated using the PWM method

**Voltage Withstand Testing**  
 AC: 0.2 V to 5.00 kV  
 0.01 mA to 20.0 mA

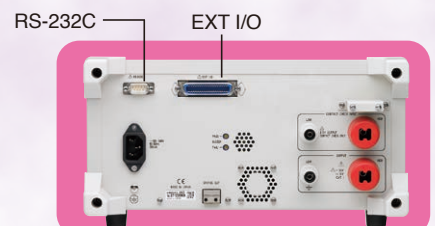

### EXT I/O Output Signals

External control can be provided by various signals (signal lines have photocoupler isolation)

| Pin   | I/O | Signal   | Function  |
|-------|-----|----------|---|
| 1     | OUT | READY    | LO when in "ready state"                              |
| 2     | OUT | L-FAIL   | LO when in "fail state" for the lower bound           |
| 3     | OUT | U-FAIL   | LO when in "fail state" for the upper bound           |
| 4     | OUT | PASS     | LO when in "pass state"                               |
| 5     | OUT | TEST     | LO when in "test state"                               |
| 6     | OUT | H.V.ON   | LO when voltage is present at the output terminals    |
| 7     | IN  | EXT-E    | When LO, external I/O input signals are enabled       |
| 8     | IN  | START    | When LO, it functions as a "Start" key                |
| 9     | IN  | STOP     | When LO, it functions as a "Stop" key                 |
| 10    | IN  | INT.LOCK | Interlock engaged when open                           |
| 11    | OUT | W-MODE   | LO during voltage withstand testing                   |
| 12    | OUT | I-MODE   | LO during insulation testing                          |
| 13    | OUT | W-FAIL   | LO when in "fail state" for voltage withstand testing |
| 14    | OUT | I-FAIL   | LO when in "fail state" for insulation testing        |
| 15-16 | IN  | ISO.GND  | Ground inputs for external devices                    |

| Pin   | I/O | Signal   | Function                              |
|-------|-----|----------|---------------------------------------|
| 17-18 | IN  | EXT.COM  | Common terminals for external devices |
| 19    | OUT | STEP-END | LO when at the end of a step          |
| 20    | OUT | FILE-END | LO when at the end of a file          |
| 21    | IN  | FILE-E   | LO when FILE 0 to 4 is in use         |
| 22    | IN  | FILE-0   | File selection                        |
| 23    | IN  | FILE-1   | File selection                        |
| 24    | IN  | FILE-2   | File selection                        |
| 25    | IN  | FILE-3   | File selection                        |
| 26    | IN  | FILE-4   | File selection                        |
| 33-34 | OUT | ISO.DCV  | Internal power 5V DC (60 mA)          |
| 35-36 | IN  | EXT.DCV  | External power supply (5 to 30V DC)   |

### Various Function Settings

1. PASS Hold function
2. FAIL Hold function
3. Hold function
4. Momentary out
5. Double actions
6. FAIL mode
7. "START" interface command
8. Interlock function
9. Maximum Output Voltage
10. Insulation Resistance measurement range
11. Insulation Resistance Test End mode
12. Ramp Timer setting
13. PC Interface
14. Electrical Discharge function
15. TEST signal output

### Status Out

When the output conditions set by the DIP switches are satisfied (OR condition), output is provided at relay contacts.

|              |                           |
|--------------|---------------------------|
| 1. H.V.ON    | Output voltage generation |
| 2. TEST      | Testing in progress       |
| 3. PASS      | Passed                    |
| 4. FAIL      | Failed                    |
| 5. INT.LOCK  | Interlocked               |
| 6. READY     | Ready                     |
| 7. EXT.CONT. | Under external control    |
| 8. POWER.ON  | Powers the 3159 on        |

| Pin   | I/O | Signal   | Function  |
|-------|-----|----------|---|
| 1     | OUT | READY    | LO when in "ready state"                              |
| 2     | OUT | L-FAIL   | LO when in "fail state" for the lower bound           |
| 3     | OUT | U-FAIL   | LO when in "fail state" for the upper bound           |
| 4     | OUT | PASS     | LO when in "pass state"                               |
| 5     | OUT | TEST     | LO when in "test state"                               |
| 6     | OUT | H.V.ON   | LO when voltage is present at the output terminals    |
| 7     | IN  | EXT-E    | When LO, external I/O input signals are enabled       |
| 8     | IN  | START    | When LO, it functions as a "Start" key                |
| 9     | IN  | STOP     | When LO, it functions as a "Stop" key                 |
| 10    | IN  | INT.LOCK | Interlock engaged when open                           |
| 11    | OUT | W-MODE   | LO during voltage withstand testing                   |
| 12    | OUT | I-MODE   | LO during insulation testing                          |
| 13    | OUT | W-FAIL   | LO when in "fail state" for voltage withstand testing |
| 14    | OUT | I-FAIL   | LO when in "fail state" for insulation testing        |
| 15-18 | IN  | ISO.COM  | Ground inputs for external devices                    |
| 33-36 | OUT | ISO.DCV  | Internal power 15V DC (100 mA)                        |

1. PASS Hold function
2. FAIL Hold function
3. Hold function
4. Momentary out
5. Double actions
6. FAIL mode
7. "START" RS command
8. Interlock function
9. Voltage Comparator position
10. Insulation Resistance measurement range
11. Insulation Resistance Test End mode

| Pin   | I/O | Signal     | Function   |
|-------|-----|------------|--|
| 1     | OUT | READY      | Low in ready state                                     |
| 2     | OUT | L-FAIL     | Low in FAIL state (lower bound)                        |
| 3     | OUT | U-FAIL     | Low in FAIL state (upper bound)                        |
| 4     | OUT | PASS       | Low in PASS state                                      |
| 5     | OUT | TEST       | Low in test state                                      |
| 6     | OUT | H.V.ON     | Low when voltage is present at output terminals        |
| 7     | IN  | EXT-E      | When low, external I/O input signals are enabled       |
| 8     | IN  | START      | When low, same function as START key                   |
| 9     | IN  | STOP       | When low, same function as STOP key                    |
| 10    | IN  | INT.LOCK   | Interlock on open                                      |
| 11    | OUT | W-MODE     | Low during withstanding voltage testing                |
| 12    | OUT | I-MODE     | Low during insulation resistance testing               |
| 13    | OUT | W-FAIL     | Low in FAIL state during withstand voltage testing     |
| 14    | OUT | I-FAIL     | Low in FAIL state during insulation resistance testing |
| 15-18 | IN  | ISO.COM    | Ground inputs for external devices                     |
| 22-25 | IN  | MEM-0 to 3 | Saved test selected pins                               |
| 27    | IN  | MEM-E      | When low, enables memory selected pins                 |
| 28-29 | OUT | MODE-0,1   | Current test mode                                      |
| 33-36 | OUT | ISO.DCV    | Internal DC 15 V power supply (100 mA)                 |

1. Contact check function improves test reliability
2. Judgment output at forced stop
3. Continued analytical testing after FAIL judgments
4. Ramp timer function
5. True effective value display
6. Eliminate the effects of supply voltage fluctuations
7. Delay timer function
8. Continuous full-auto withstanding voltage and insulation resistance testing
9. Interlock function

**Specifications** Accuracy guaranteed for 1 year, Post-adjustment accuracy guaranteed for 1 year

**■ Voltage Withstand Testing**

|                                     | <b>Model 3153</b><br>AUTOMATIC INSULATION / WITHSTANDING HITESTER   |   | <b>Model 3159</b><br>INSULATION / WITHSTANDING HITESTER  | <b>Model 3174</b><br>AC AUTOMATIC INSULATION WITHSTANDING HITESTER                   |
|-------------------------------------|---|---|--|--|
|                                     | AC  | DC  | AC   |  |
| <b>Output voltage</b>               | 0.20 kV to 5.00 kV  |   | 0.2 V AC to 5.00 kV AC   |  |
| <b>Voltage output method</b>        | PWM switching method (zero-switching)   | PWM switching method  | Zero-switching   | PWM switching method (zero-switching)  |
| <b>Transformer capacity</b>         | 500 VA (rated 30 minutes)   | N/A   | 500 VA (rated 30 minutes)  | AC: 100 VA (continuous)  |
| <b>Output capacity</b>              | N/A   | 50 VA (continuous)  | N/A  | N/A  |
| <b>Voltage adjustment method</b>    | Digital setting (0.01 kV setting resolution)  |   | Manual adjustment  | Digital setting (0.01 kV setting resolution)   |
| <b>Output voltage accuracy</b>      | ±1.5% of setting voltage ±2 dgt.  |   | N/A  | ±1.5% of setting voltage ±2 dgt.   |
| <b>Fluctuation rate</b>             | ±7% or less<br>(max. 5 kV at 100 mA → no load: Resistance load)*2   | ±16% or less<br>(max. 5 kV at 10 mA → no load: Resistance load)*2   | N/A  | 15% or less (At Maximum rated load → no load converge to set value within 1 second)  |
| <b>Voltage waveform</b>             | Sine wave<br>(5% or less distortion, unloaded)  | N/A   | Power waveform   | Sine wave  |
| <b>Voltage frequency</b>            | 50 Hz/60 Hz, ±0.2%  | N/A   | Power synchronization  | 50 Hz/60 Hz, ±0.2%   |
| <b>Output ripple voltage</b>        | N/A   | 6% of output voltage or less<br>(at 5 kV DC, 10 mA, resistive load) | N/A  | N/A  |
| <b>Output current</b>               | 100 mA AC *1  | 10 mA DC (continuous)   | N/A  | 20 mA AC   |
| <b>Voltmeter</b>                    | Average rectified effective value display   | Average display   | Average rectified effective value display  | True RMS   |
|                                     | Digital: 0.00 to 5.00 kV (full scale)<br>Accuracy: ±1.5% f.s.<br>Analog: 0 to 5 kV (full scale)<br>Accuracy: ±5% f.s. |   | Digital: 0.00 to 5.00 kV (full scale)<br>Accuracy: ±1.5% f.s.<br>Analog: 0 to 5 kV (full scale)<br>Accuracy: ±5% f.s.a | Accuracy: ±1.5% f.s.   |
| <b>Current measurement range</b>    | 0.01 mA to 100.0 mA AC  | 0.01 mA to 10.0 mA DC   | 0.01 mA to 120.0 mA AC   | 0.01 mA to 20.0 mA AC  |
| <b>Indicated value range</b>        | 10 or 100 mA  | 10 mA   | 2, 8, 32 or 120 mA   | 10 mA/20 mA  |
| <b>Measurement resolution</b>       | 0.00 to 10.00 or 0.01 mA (10-mA range)<br>10.1 to 100.0 or 0.1 mA (100-mA range, AC only)                             |   | 0.01 mA (2- or 8-mA range), 0.1 mA (32-mA range), 1 mA (120-mA range)  | 0.00 mA to 9.99 mA, 0.01 mA (10-mA range)<br>0.0 mA to 20.0 mA, 0.1 mA (20-mA range) |
| <b>Current measurement accuracy</b> | ± (2% rdg. + 5 dgt.) common to each range *3  |   | ± (3% f.s. + 20 µA) for all ranges (at 5% power distortion or less)  | ±2% rdg. ±0.05 mA (10 mA range)<br>±2% rdg. ±0.5 mA (20 mA range)                    |

\*1. Time vs. Output Voltage (at 23°C ambient)

| Current Measurement Range | Max. Test Time | Standby Time |
|---------------------------|----------------|--------------|
| 1 ≤ 60 mA                 | continuous     | none         |
| 60 mA < 1 ≤ 100 mA        | 15 minutes     | 15 minutes   |

\*2. Unloaded = 40 MΩ load (instrument input impedance)

\*3. Plus scanner accuracy, when used.

**■ Insulation Resistance Testing**

|                                   | <b>Model 3153</b>   | <b>Model 3159</b>   | <b>Model 3174</b>  |
|-----------------------------------|---|---|--|
| <b>Test voltage</b>               | Output voltage: Positive polarity 50 V to 1200 V DC<br>Voltage adjustment method: Digital setting (1 V resolution)<br>Output voltage accuracy: ±1.5% ±2 dgt. of setting level | Rated voltage: 500 V or 1000 V DC<br>Unloaded voltage: 1 to 1.2 times rated voltage                 | Rated voltage: 500 V or 1000 V DC<br>Unloaded voltage: 1 to 1.2 times rated voltage            |
| <b>Rated measurement current</b>  | 1 mA  | 1 mA to 1.2 mA  | 1 mA to 1.2 mA   |
| <b>Short-circuit current</b>      | 200 mA or less  | 4 mA to 5 mA (500 V)<br>2 mA to 3 mA (1000 V)   | 4 mA to 5 mA (500 V)<br>2 mA to 3 mA (1000 V)  |
| <b>Voltmeter</b>                  | Average display<br>Digital: 0 to 1200 V DC (full scale)<br>Accuracy: ±1.5% rdg. ±2 dgt.<br>Analog: 0 to 1200 V DC<br>Accuracy: ±5% f.s. (5 kV full scale)                     | Average display<br>Digital: 0 to 1200 V DC (f.s.)   | Digital meter<br>0 to 1000 V DC (f.s.)<br>Accuracy: ±30 V                                      |
|                                   |   | Analog: N/A   | Analog: N/A  |
| <b>Measurement range/accuracy</b> | 0.100 MΩ to 1.049 MΩ<br>1.05 MΩ to 10.49 MΩ*1<br>10.5 MΩ to 104.9 MΩ*1<br>105 MΩ to 9999 MΩ*1<br>Fundamental accuracy: ±4% rdg.*2   | 0.5 MΩ to 999 MΩ (500V)/±4% rdg.<br>1 MΩ to 999 MΩ (1000V)/±4% rdg.<br>1000 MΩ to 2000 MΩ /±8% rdg. | 0.5 MΩ to 999 MΩ (500 V),<br>1 MΩ to 999 MΩ (1000 V): ±4% rdg.<br>1000 MΩ to 2000 MΩ: ±8% rdg. |

\*1. Measurement range changes according to test voltage.

\*2. Plus scanner accuracy, when used.

\* Accuracy guaranteed for 1 year, Post-adjustment accuracy guaranteed for 1 year

## Decision Function

|                                 | Model 3153  | Model 3159   | Model 3174   |
|---------------------------------|---|--|--|
| <b>Decision method</b>          | Window comparison method (digital specification)  |  |  |
| <b>Decision results</b>         | UPPER-FAIL: Measured current (insulation resistance value) exceeded the specified upper bound.<br>PASS: Measured current (insulation resistance value) was between the specified upper and lower bounds during the specified time elapsed<br>LOWER-FAIL: Measured current (insulation resistance value) was less than the specified lower bound |  |  |
| <b>Decision processing</b>      | For each decision result, output the display portion, the beeper sound, and EXT I/O signal  |  |  |
| <b>Specification ranges</b>     | Voltage withstand testing:<br>AC V: 0.1 mA to 100 mA (upper bound) / 0.1 mA to 99 mA (lower bound)<br>DC V: 0.1 mA to 10 mA (upper bound) / 0.1 mA to 9.9 mA (lower bound)<br>Insulation testing: 0.10 MΩ to 9999 MΩ (same upper/lower bounds)  | Voltage withstand testing:<br>0.1 mA to 120 mA (upper bound) / 0.1 mA to 119 mA (lower bound)<br>Insulation testing (Model 3159 only):<br>0.2 MΩ to 2000 MΩ (same upper/lower bounds)  | Voltage withstand testing:<br>0.1 mA to 20 mA (upper bound) / 0.1 mA to 19.9 mA (lower bound)<br>Insulation testing (Model 3159 only):<br>0.2 MΩ to 2000 MΩ (same upper/lower bounds)  |
| <b>Specification resolution</b> | Voltage withstand testing:<br>0.1 mA (0.1 mA to 9.9 mA), 1 mA (10 mA to 100 mA)<br>Insulation testing:<br>0.01 MΩ (0.10 MΩ to 9.99 MΩ), 0.1 MΩ (10.0 MΩ to 99.9 MΩ),<br>1 MΩ (100 MΩ to 9999 MΩ)  | Voltage withstand testing:<br>0.1 mA (0.1 mA to 9.9 mA), 1 mA (10 mA to 120 mA)<br>Insulation testing (Model 3159 only):<br>0.01 MΩ (0.2 MΩ to 2 MΩ), 0.1 MΩ (2.1 MΩ to 20 MΩ),<br>1 MΩ (21 MΩ to 200 MΩ), 10 MΩ (210 MΩ to 2000 MΩ) | Voltage withstand testing: 0.1 mA<br>Insulation testing (Model 3159 only):<br>0.01 MΩ (0.2 MΩ to 2 MΩ), 0.1 MΩ (2.1 MΩ to 20 MΩ),<br>1 MΩ (21 MΩ to 200 MΩ), 10 MΩ (210 MΩ to 2000 MΩ) |

## Timers

|  | Model 3153   | Model 3159  | Model 3174   |
|--|--|---|--|
| <b>Timer section</b>                                 | Setting range: 0.3 s to 999 s<br>Setting resolution: 0.1 s (0.3 s to 99.9 s), 1 s (100 s to 999 s)<br>Accuracy: ±0.5% of specified value   | Setting range: 0.5 to 999 s<br>Setting resolution/accuracy:<br>0.1 s (0.5 s to 99.9 s), ±50 ms; 1 s (100 s to 999 s) ±0.5 s | Setting range: 0.3 to 999 s<br>Setting resolution/accuracy:<br>0.1 s (0.3 s to 99.9 s), ±50 ms; 1 s (100 s to 999 s) ±0.5 s                |
|  | Action: (At ON Setting) Displays the time that is counted down from the start<br>(At OFF Setting) Display the time that has elapsed from the start   |   |  |
| <b>Ramp timer (withstand test time)</b>              | Setting range: 0.1 s to 99.9 s ramp-up and -down specified separately<br>Setting resolution/accuracy: 0.1 s, ±0.5% of specified value  | N/A   | Setting range: 0.1 s to 99.9 s. The ramp-up time and ramp-down time can be set individually.<br>Setting resolution/accuracy: 0.1 s, ±50 ms |
| <b>Delay timer (insulation resistance test time)</b> | Setting range: 0.1 s to 99.9 s<br>Setting resolution/accuracy: 0.1 s, ±0.5% of specified value<br>Action: specify a delay time after testing is set to begin to inhibit decisions during that time | Non-deterministic interval: 0.5 s<br>(Mask time until determination begins during insulation resistance testing)            | Setting range: 0.1 s to 99.9 s<br>Setting resolution/accuracy: 0.1 s, ±50 ms   |

## Interfaces

|                | Model 3153  | Model 3159  | Model 3174  |
|----------------|---|---|---|
| <b>EXT I/O</b> | Open-collector outputs, active low, max. 30 V DC loaded voltage, all signal lines photocoupler-isolated |   |   |
| <b>EXT SW</b>  | START, STOP, SW.EN (panel terminal switch enabled), connection point inputs                             |   |   |
| <b>RS-232C</b> | Start-stop synchronization, full duplex, 9600 or 19200 bps  | Start-stop synchronization, full duplex, 9600 bps | Start-stop synchronization, full duplex, 9600 / 19200 bps |
| <b>GP-IB</b>   | IEEE 488.2 (1987) compliant   | N/A   |   |

## General Specifications

|   | Model 3153   | Model 3159  | Model 3174   |
|---|--|---|--|
| <b>Display</b>  | Fluorescent display tube (digital display), analog meter   | Fluorescent display tube (digital display), analog meter  | Fluorescent display tube (digital display)   |
| <b>Monitor functions</b>                                      | Output voltage, detected current, measured resistance  |   |  |
| <b>Monitor period</b>   | 2 times per second minimum   |   |  |
| <b>Operating temperature range</b>                            | 0 to 40 °C, 80% RH maximum (no condensation)   |   |  |
| <b>Storage temperature range</b>                              | -10 to 50 °C, 90% RH maximum (no condensation)   |   |  |
| <b>Temperature and humidity range for guaranteed accuracy</b> | 23 ± 5 °C, 80% RH maximum (no condensation) (after 10 minutes warm-up for 3153, or 5 minutes warm-up for 3159)   |   |  |
| <b>Operating environment</b>                                  | Indoors, Pollution degree 2, Up to 2000 m (6562 ft.)   |   |  |
| <b>Power supply voltage</b>                                   | 100 V to 240 V AC (installed fuse depends on actual voltage, so specify supply voltage when ordering)<br>100 V to 120 V AC: installed fuse 250V T10AL<br>200 V to 240 V AC: installed fuse 250V T5AL | 220 V AC (3159-02)<br><del>120 V AC (3159-01)</del> ...discontinued<br><del>230 V AC (3159-03)</del> ...discontinued<br><del>240 V AC (3159-04)</del> ...discontinued | 100 V to 240 V AC (Voltage fluctuations of ±10% from the rated supply voltage are taken into account.)                                 |
| <b>Power supply frequency</b>                                 | 50 Hz/60 Hz  |   |  |
| <b>Max. power consumption</b>                                 | 1000 VA  | 800 VA  | 200 VA   |
| <b>Dimensions</b>   | Approx. 320 mm (12.60 in)W × 155 mm (6.10 in)H × 480 mm (18.9 in)D   | Approx. 320 mm (12.60 in)W × 155 mm (6.10 in)H × 330 mm (12.99 in)D   | Approx. 320 mm (12.60 in)W × 155 mm (6.10 in)H × 395 mm (15.55 in)D  |
| <b>Mass</b>   | Approx. 18 kg (634.9 oz)   | Approx. 20.5 kg (723.1 oz) (3159-01),<br>21.5 kg (758.4 oz) (3159-02/-03/-04)   | Approx. 15 kg (529.1 oz)   |
| <b>Accessories</b>  | H.V. Test lead 9615 (high voltage side and return, 1 each) ×1, Power cord ×1, Instruction manual ×1, Spare fuse ×1   |   | H.V. Test lead 9615 (high voltage side and return, 1 each) ×1, Power cord ×1, Instruction manual ×1, Disconnection prevention plate ×1 |

Model No. (Order Code) **3153** (Insulation, AC/DC Withstanding Voltage)



\*The 9615 is bundled

**Input/Output cords**

- H.V. TEST LEAD 9615**  
Red, Black each 1, 1.5 m (4.92 ft) length
- REMOTE CONTROL BOX (SINGLE) 9613**  
For Start/Stop control, 1.5m (4.92 ft) cord length
- REMOTE CONTROL BOX (DUAL) 9614**  
For Start/Stop control, 1.5m (4.92 ft) cord length

**PC communication**

- SAFETY TEST DATA MANAGEMENT SOFTWARE 9267**  
For PC control application software
- RS-232C CABLE 9637**  
For the PC, 9pin - 9pin, cross, 1.8m (5.91 ft) length
- GP-IB CONNECTOR CABLE 9151-02**  
2 m (6.56 ft) length

**Other**

- HIGH VOLTAGE SCANNER 3930**  
Automatic multipoint testing of high voltages

Model No. (Order Code) **3159-02** (For 220 V power supplies only)



\*The 9615 is bundled

**Input/Output cords**

- H.V. TEST LEAD 9615**  
Red, Black each 1, 1.5 m (4.92 ft) length
- REMOTE CONTROL BOX (SINGLE) 9613**  
For Start/Stop control, 1.5m (4.92 ft) cord length
- REMOTE CONTROL BOX (DUAL) 9614**  
For Start/Stop control, 1.5m (4.92 ft) cord length

**PC communication**

- SAFETY TEST DATA MANAGEMENT SOFTWARE 9267**  
For PC control application software
- RS-232C CABLE 9637**  
For the PC, 9pin - 9pin, cross, 1.8m (5.91 ft) length

Model No. (Order Code) **3174** (Insulation/Withstanding Voltage [AC])

Note: To perform contact checks, please purchase another High Voltage Test Lead 9615 set separately.



\*The 9615 is bundled

**Input/Output cords**

- H.V. TEST LEAD 9615**  
Red, Black each 1, 1.5 m (4.92 ft) length
- REMOTE CONTROL BOX (SINGLE) 9613**  
For Start/Stop control, 1.5m (4.92 ft) cord length
- REMOTE CONTROL BOX (DUAL) 9614**  
For Start/Stop control, 1.5m (4.92 ft) cord length

**PC communication**

- SAFETY TEST DATA MANAGEMENT SOFTWARE 9267**  
For PC control application software
- RS-232C CABLE 9637**  
For the PC, 9pin - 9pin, cross, 1.8m (5.91 ft) length

# Model ST5520

## INSULATION TESTER

- Rapidly assess in as fast as 50 ms
- Quick discharge of residual voltage
- Freely configurable test voltage
  - Set from 25 V to 1000 V, 1 V resolution --
- Contact check function
  - Prevents errors due to poor contact --
- Short-circuit check function
  - Stops potential defects from reaching the market --



Basic Specifications Accuracy guaranteed for 1 year.

|                                      |  |
|--------------------------------------|--|
| Testing voltage (measurement ranges) | 25 V ≤ V < 100 V (2/20/200 MΩ),<br>100 V ≤ V < 500 V (2/20/200/2000 MΩ),<br>500 V ≤ V ≤ 1000 V (2/20/200/4000 MΩ)        |
| Basic accuracy                       | ±2 % rdg. ±5 dgt.<br>25 V ≤ V < 100 V [0 to 20 MΩ]<br>100 V ≤ V < 500 V [0 to 20 MΩ]<br>500 V ≤ V ≤ 1000 V [0 to 200 MΩ] |
| Measurement speed                    | Fast: 30 ms/time, Slow: 500 ms/time (selectable)   |
| Memory capacity                      | up to 10 items (can be saved/loaded)   |

Model No. (Order Code) **ST5520** (Built-in external I/O output)  
**ST5520-01** (Built-in BCD output)

Note: The ST5520 and ST5520-01 cannot be operated alone. Please select and purchase the optional test leads to accommodate your application.

\*Please contact your HIOKI distributor for extending the L2200 cable length

**Input/Output cords**

- TEST LEAD L2200**  
70 cm (2.30ft) length, detachable large alligator clips or needle tips are bundled, CAT IV 600V, CAT III 1000V
- CONNECTION CORD L9257**  
1.2 m (3.94 ft) length
- SWITCHED PROBE 9299**  
80 cm (2.62 ft) length
- OUTPUT CORD L9094**  
3.5 mm (0.14in) dia. mini plug to banana, 1.5m (4.92ft) length
- CONVERSION ADAPTER 9199**  
Receiving side banana (female), output BNC (male)

**PC communication**

- RS-232C CABLE 9637**  
For the PC, 9pin - 9pin, cross, 1.8m (5.91 ft) length

Note: Company names and product names appearing in this catalog are trademarks or registered trademarks of various companies.

**HIOKI**  
HIOKI E. E. CORPORATION

**HEADQUARTERS**  
81 Koizumi,  
Ueda, Nagano 386-1192 Japan  
<https://www.hioki.com/>



Scan for all regional contact information

DISTRIBUTED BY

**CALPLUS**  
Die Kompetenz in der Messtechnik

**CalPlus GmbH - Zentrale**  
Heerstraße 32  
14052 Berlin  
Tel.: 030 214982-0  
Fax: 030 214982-50  
office@calplus.de  
www.calplus.de

**CalPlus GmbH**  
Normannenweg 30  
20537 Hamburg  
Tel.: 040 3039595-0  
Fax: 040 3039595-50  
scopeshop@calplus.de  
www.calplus.de