

Simplifying FET Testing with 2600B System SourceMeter® SMU Instruments

APPLICATION NOTE

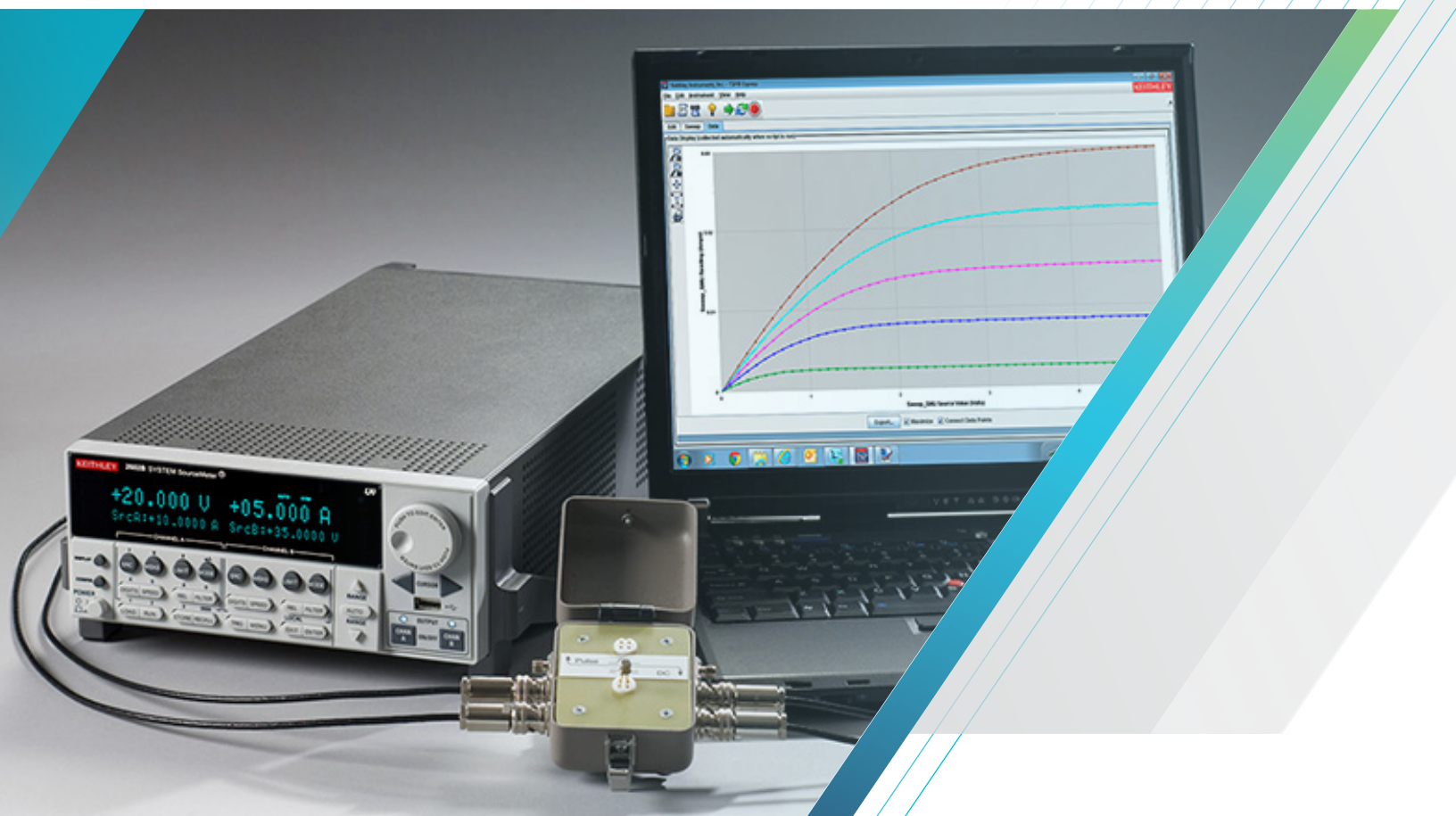

KEITHLEY
A Tektronix Company

Tektronix®

Introduction

Field effect transistors (FETs) are important semiconductor devices with many applications because they are fundamental components of many devices and electronic instruments. Some of the countless applications for FETs include their use as amplifiers, memory devices, switches, logic devices, and sensors. The most commonly used FET is the MOSFET, which is the basis for digital integrated circuits.

Characterizing FETs' current-voltage (I-V) parameters is crucial to ensuring they work properly in their intended applications and meet specifications. Some of these I-V tests may include gate leakage, breakdown voltage, threshold voltage, transfer characteristics, drain current, on-resistance, etc. FET testing often involves the use of several instruments, including a sensitive ammeter, multiple voltage sources, and a voltmeter. Programming and synchronizing multiple instruments, however, can be tedious and time consuming. The use of a turnkey semiconductor characterization system is one alternative approach that solves the integration problem and offers other important benefits, but systems of this type typically cost tens of thousands of dollars. A third approach involves using Source Measurement Units (SMUs) to perform parameter testing on FETs and other semiconductor devices. An SMU is an instrument that can quickly and accurately source and measure both current and voltage. The number of SMUs required in the test usually depends on the number of FET terminals that must be biased and/or measured.

This application note explains how to simplify I-V measurements on FETs using a Series 2600B System SourceMeter SMU Instrument with the TSP® Express embedded software tool. The Series 2600B family of one- and two-channel SMUs offers a range of instruments ideal for electrical characterization of FETs that can source and measure over a wide range of voltage and current. These SMUs have current resolution to 0.1fA and can be current limited to prevent damage to the device. The TSP Express

software tool simplifies performing common I-V tests on FETs and other semiconductor devices, without programming or installing software. **Figure 1** illustrates a typical test setup.

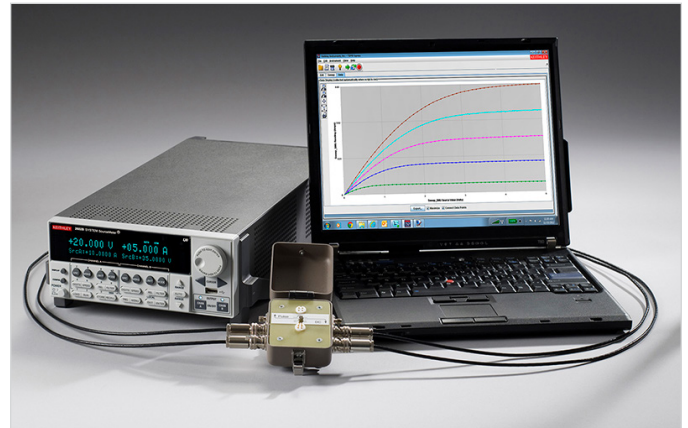

Figure 1. Model 2636B with the TSP Express software tool generating a drain family of curves on a MOSFET.

Field Effect Transistors

The field effect transistor is a majority charge-carrier device in which the current-carrying capability is varied by an applied electric field. The FET has three main terminals: the gate, the drain, and the source. A voltage applied to the gate terminal (V_g) controls the current that flows from the source (I_s) to the drain (I_D) terminals.

The many types of FETs include the MOSFET (metal-oxide-semiconductor), MESFET (metal-semiconductor), JFET (junction), OFET (organic), GNRFET (graphene nano-ribbon), and CNTFET (carbon nanotube). These FETs differ in the design of their channels. **Figure 2** illustrates the MOSFET, CNTFET, and JFET.

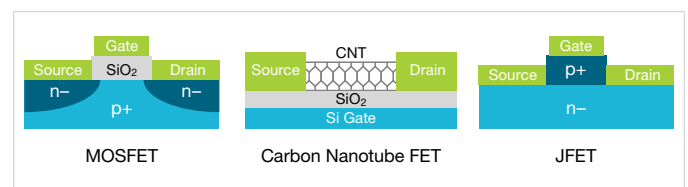

Figure 2. MOSFET (insulated gate), CNTFET (carbon nanotube channel), and JFET (junction FET).

Using a Series 2600B SMU for FET Testing

A FET's I-V characteristics can be used to extract many parameters about the device, to study the effects of fabrication techniques and process variations, and to determine the quality of the contacts. **Figure 3** illustrates a DC I-V test configuration for a MOSFET using a two-channel Series 2600B SMU. In this configuration, the Force HI terminal of Channel 1 (SMU CH1) is connected to the gate of the MOSFET and the Force HI terminal Channel 2 (SMU CH2) is connected to the drain. The source terminal of the MOSFET is connected to the Force LO terminals of both SMU channels or to a third SMU if it is necessary to source and measure from all three terminals of the MOSFET.

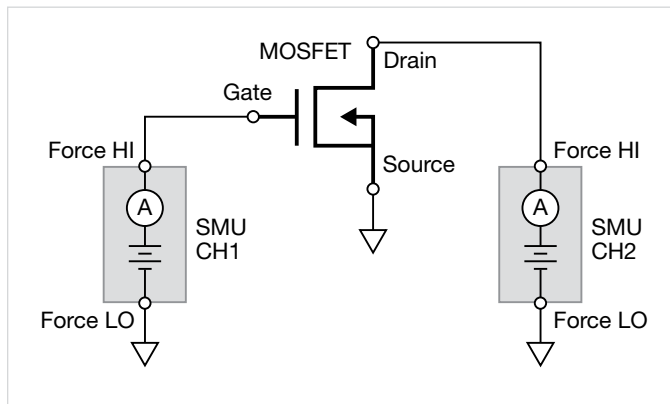

Figure 3. MOSFET test configuration using two SMU channels.

Once the device is set up and connected to the SMU, the control software must be configured to automate the measurements, such as with the TSP Express software tool embedded into Series 2600B SMUs. As shown in **Figure 4**, it's simple to connect the instrument to any computer with the supplied Ethernet cable. Entering the IP address of the SMU into the URL line of any web browser will open the instrument's web page. From that page, the user can launch TSP Express and configure the desired test using the project wizard. These tests, or projects, can be saved and recalled for future use.

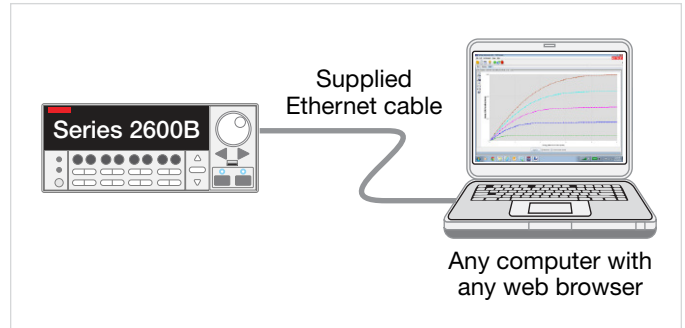

Figure 4. Connecting a Series 2600B SMU to a computer.

A common I-V test performed on a MOSFET is the drain family of curves ($V_{DS}-I_D$). With this test, SMU CH1 steps the gate voltage (V_G) while SMU CH2 sweeps the drain voltage (V_D) and measures the resulting drain current (I_D). Once the two SMUs are configured to perform the test, the data can be generated and plotted on the screen in real time. **Figure 5** shows a screen capture of a MOSFET drain family of curves created by using the two-channel Model 2636B SMU with the TSP Express software. This I-V data can be exported directly to a .csv file with a single button click, then imported into a spreadsheet for further analysis.

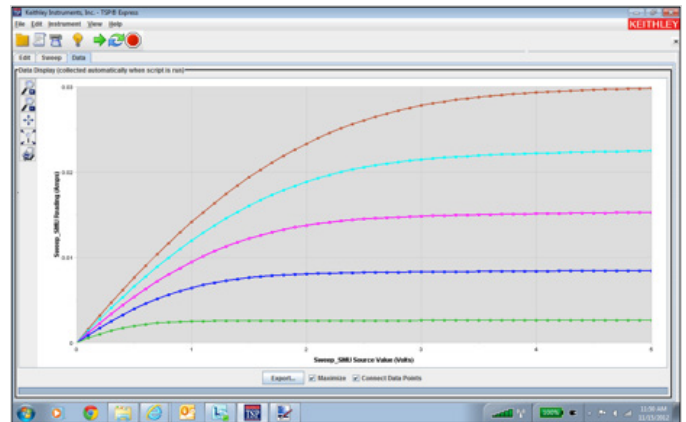

Figure 5. Screen capture of MOSFET drain family of curves measured by the two-channel Model 2636B using TSP Express software.

The data in the software can also be displayed in a table view (Figure 6). For each SMU channel, the current, voltage, and time appear in the table. This data can also be saved to a file.

SourceMeter1			SourceMeter2		
Timestamp (seconds)	Source Value (Vrms)	Reading (Amps)	Timestamp (seconds)	Source Value (Vrms)	Reading (Amps)
0.0	0.0	1.00000E-6	0.0	0.0	1.00000E-6
0.0100	0.10	1.00000E-6	0.0100	0.10	0.00000E+0
0.0200	0.20	1.00000E-6	0.0200	0.20	0.00000E+0
0.0300	0.30	1.00000E-6	0.0300	0.30	0.00000E+0
0.0400	0.40	1.00000E-6	0.0400	0.40	0.00000E+0
0.0500	0.50	1.00000E-6	0.0500	0.50	0.00000E+0
0.0600	0.60	1.00000E-6	0.0600	0.60	0.00000E+0
0.0700	0.70	1.00000E-6	0.0700	0.70	0.00000E+0
0.0800	0.80	1.00000E-6	0.0800	0.80	0.00000E+0
0.0900	0.90	1.00000E-6	0.0900	0.90	0.00000E+0
0.1000	1.00	1.00000E-6	0.1000	1.00	0.00000E+0
0.1100	1.10	1.00000E-6	0.1100	1.10	0.00000E+0
0.1200	1.20	1.00000E-6	0.1200	1.20	0.00000E+0
0.1300	1.30	1.00000E-6	0.1300	1.30	0.00000E+0
0.1400	1.40	1.00000E-6	0.1400	1.40	0.00000E+0
0.1500	1.50	1.00000E-6	0.1500	1.50	0.00000E+0
0.1600	1.60	1.00000E-6	0.1600	1.60	0.00000E+0
0.1700	1.70	1.00000E-6	0.1700	1.70	0.00000E+0
0.1800	1.80	1.00000E-6	0.1800	1.80	0.00000E+0
0.1900	1.90	1.00000E-6	0.1900	1.90	0.00000E+0
0.2000	2.00	1.00000E-6	0.2000	2.00	0.00000E+0
0.2100	2.10	1.00000E-6	0.2100	2.10	0.00000E+0
0.2200	2.20	1.00000E-6	0.2200	2.20	0.00000E+0
0.2300	2.30	1.00000E-6	0.2300	2.30	0.00000E+0
0.2400	2.40	1.00000E-6	0.2400	2.40	0.00000E+0
0.2500	2.50	1.00000E-6	0.2500	2.50	0.00000E+0
0.2600	2.60	1.00000E-6	0.2600	2.60	0.00000E+0
0.2700	2.70	1.00000E-6	0.2700	2.70	0.00000E+0
0.2800	2.80	1.00000E-6	0.2800	2.80	0.00000E+0
0.2900	2.90	1.00000E-6	0.2900	2.90	0.00000E+0
0.3000	3.00	1.00000E-6	0.3000	3.00	0.00000E+0
0.3100	3.10	1.00000E-6	0.3100	3.10	0.00000E+0
0.3200	3.20	1.00000E-6	0.3200	3.20	0.00000E+0
0.3300	3.30	1.00000E-6	0.3300	3.30	0.00000E+0
0.3400	3.40	1.00000E-6	0.3400	3.40	0.00000E+0
0.3500	3.50	1.00000E-6	0.3500	3.50	0.00000E+0
0.3600	3.60	1.00000E-6	0.3600	3.60	0.00000E+0
0.3700	3.70	1.00000E-6	0.3700	3.70	0.00000E+0
0.3800	3.80	1.00000E-6	0.3800	3.80	0.00000E+0
0.3900	3.90	1.00000E-6	0.3900	3.90	0.00000E+0
0.4000	4.00	1.00000E-6	0.4000	4.00	0.00000E+0
0.4100	4.10	1.00000E-6	0.4100	4.10	0.00000E+0
0.4200	4.20	1.00000E-6	0.4200	4.20	0.00000E+0
0.4300	4.30	1.00000E-6	0.4300	4.30	0.00000E+0
0.4400	4.40	1.00000E-6	0.4400	4.40	0.00000E+0
0.4500	4.50	1.00000E-6	0.4500	4.50	0.00000E+0
0.4600	4.60	1.00000E-6	0.4600	4.60	0.00000E+0
0.4700	4.70	1.00000E-6	0.4700	4.70	0.00000E+0
0.4800	4.80	1.00000E-6	0.4800	4.80	0.00000E+0
0.4900	4.90	1.00000E-6	0.4900	4.90	0.00000E+0
0.5000	5.00	1.00000E-6	0.5000	5.00	0.00000E+0
0.5100	5.10	1.00000E-6	0.5100	5.10	0.00000E+0
0.5200	5.20	1.00000E-6	0.5200	5.20	0.00000E+0
0.5300	5.30	1.00000E-6	0.5300	5.30	0.00000E+0
0.5400	5.40	1.00000E-6	0.5400	5.40	0.00000E+0
0.5500	5.50	1.00000E-6	0.5500	5.50	0.00000E+0
0.5600	5.60	1.00000E-6	0.5600	5.60	0.00000E+0
0.5700	5.70	1.00000E-6	0.5700	5.70	0.00000E+0
0.5800	5.80	1.00000E-6	0.5800	5.80	0.00000E+0
0.5900	5.90	1.00000E-6	0.5900	5.90	0.00000E+0
0.6000	6.00	1.00000E-6	0.6000	6.00	0.00000E+0

Figure 6. MOSFET I-V curve data displayed in a table in TSP Express.

Without changing connections to the device, the TSP Express software allows users to perform other common I-V FET tests such as the Drain Current (I_D) as a function of Gate Voltage (V_G). For this test, the gate voltage is swept and the resulting drain current is measured at a constant drain voltage.

Figure 7 shows the results of an I_D - V_G curve at a constant drain voltage. However, in this case, the generated data was exported to a file and plotted on a semi-log graph. This test can be easily reconfigured to step the drain voltage as the gate voltage is swept.

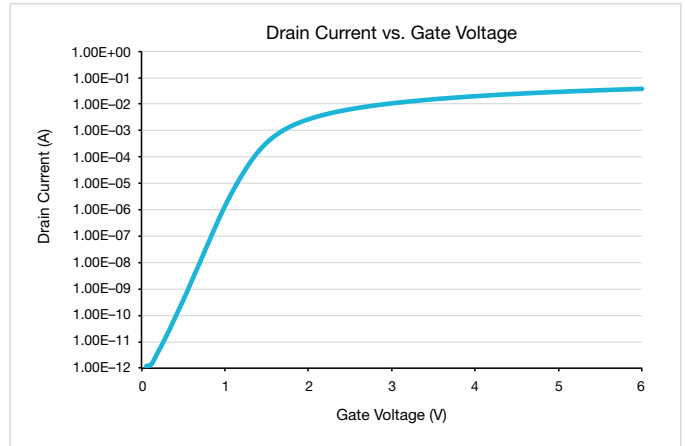

Figure 7. Drain current as a function of the gate voltage of a MOSFET generated by the Model 2636B and the TSP Express software.

The I_D - V_G data shows the many decades of drain current that were measured by the Model 2636B, from 1E-12 to 1E-2 amps. The Model 2636B is a low current SMU with 0.1fA resolution, so it's suitable for other low current FET test applications such as gate leakage current measurements. When measuring low current, it is important to employ low level measurement techniques, such as shielding and guarding, to prevent errors. Further information on optimizing low current measurements is available in Keithley's *Low Level Measurements Handbook*.

Conclusion

Parameter testing of FETs is often performed using multiple Source Measurement Units (SMUs). To simplify I-V characterization of FETs, Series 2600B SMUs with embedded TSP Express software allow generating I-V sweeps quickly and easily. With their wide dynamic range of current and voltage sourcing and measuring, Series 2600B SMUs are ideal tools for semiconductor device characterization.

Contact Information:

Australia* 1 800 709 465
Austria 00800 2255 4835
**Balkans, Israel, South Africa
and other ISE Countries** +41 52 675 3777
Belgium* 00800 2255 4835
Brazil +55 (11) 3759 7627
Canada 1 800 833 9200
Central East Europe / Baltics +41 52 675 3777
Central Europe / Greece +41 52 675 3777
Denmark +45 80 88 1401
Finland +41 52 675 3777
France* 00800 2255 4835
Germany* 00800 2255 4835
Hong Kong 400 820 5835
India 000 800 650 1835
Indonesia 007 803 601 5249
Italy 00800 2255 4835
Japan 81 (3) 6714 3010
Luxembourg +41 52 675 3777
Malaysia 1 800 22 55835
**Mexico, Central/South America
and Caribbean** 52 (55) 56 04 50 90
Middle East, Asia, and North Africa +41 52 675 3777
The Netherlands* 00800 2255 4835
New Zealand 0800 800 238
Norway 800 16098
People's Republic of China 400 820 5835
Philippines 1 800 1601 0077
Poland +41 52 675 3777
Portugal 80 08 12370
Republic of Korea +82 2 6917 5000
Russia / CIS +7 (495) 6647564
Singapore 800 6011 473
South Africa +41 52 675 3777
Spain* 00800 2255 4835
Sweden* 00800 2255 4835
Switzerland* 00800 2255 4835
Taiwan 886 (2) 2656 6688
Thailand 1 800 011 931
United Kingdom / Ireland* 00800 2255 4835
USA 1 800 833 9200
Vietnam 12060128

* European toll-free number. If not accessible, call: +41 52 675 3777



Find more valuable resources at TEK.COM

Copyright © Tektronix. All rights reserved. Tektronix products are covered by U.S. and foreign patents, issued and pending. Information in this publication supersedes that in all previously published material. Specification and price change privileges reserved. TEKTRONIX and TEK are registered trademarks of Tektronix, Inc. All other trade names referenced are the service marks, trademarks or registered trademarks of their respective companies.

100416.AH 1KW-57501-1

