

## Conducted emission pre-compliance measurements

All electronic products need to be tested for electromagnetic emissions that may negatively effect the correct operation of other equipment nearby.

Electromagnetic emissions of a product fall into two categories:

- Conducted noise, which are unwanted emissions carried on supply cables or data/control cables of a product
- Radiated noise, which are unwanted emissions that are radiated from a product and propagate in free space

This document focusses on measurement equipment and methods, limits and the relevant standards of conducted noise measurement on the power supply lines of products. The document tries to reduce the details to those necessary to carry out pre-compliance measurements in house with modest equipment.

# Common standards for conducted emissions

## Limit values:

### Standards developed by CISPR and IEC, adopted by EU countries as European standards

- **CISPR 11 / EN 55011** for industrial, scientific and medical (ISM) radio-frequency equipment
- **CISPR 13 / EN 55013** for Sound and TV Broadcast Receivers
- **CISPR 14 / EN 55014** for Household Appliances
- **CISPR 15 / EN 55015** for Lighting Equipment
- **CISPR 22 / EN 55022** for ITE products
- **CISPR 25 / EN 55025** for vehicles, boats - protection of on-board receivers
- **CISPR 32 / EN 55032** for Multimedia Equipment
- **ETSI 301-489-x** for radio equipment

### Generic EU standards

- **IEC/ EN 61000-6-3** for residential, commercial and light-industrial environments
- **IEC/ EN 61000-6-4** for industrial environments

### Regulations in United States

- Federal Communications Commission (FCC) - Code of Federal Regulation **(CFR) Title 47**  
- **Part 2, 15 and 18**

## Examples of common standards for conducted emissions

### Measuring equipment and methods

The standards listed on the previous page specify limits for conducted emissions of products. The requirements for the test set up and test equipment are specified in separate standards:

#### **CISPR 16-1**

Consists of six parts, specifies voltage, current and field measuring apparatus and test sites. These include calibration and verification aspects of measuring apparatus.

Relevant parts for conducted noise measurements are:

- Part 1-1: Measuring apparatus
- Part 1-2: Ancillary equipment - Conducted disturbances

#### **CISPR 16-2**

Consists of five parts and specifies the methods for measuring high-frequency EMC phenomena, dealing both with disturbances and immunity. Relevant parts for conducted noise measurements are:

- Part 2-1: Conducted disturbance measurements
- Part 2-2: Measurement of disturbance power

#### **CISPR 25**

This standard contains both limits and methods of measurement for equipment on board of vehicles and boats

## Conducted emission limits

- Typical Frequency Range -150 kHz to 30 MHz (may down to 9 kHz or up to 108 MHz)
- Limits - Average and Quasi-peak or Peak and Quasi-peak
- Measured by using average detector, peak detector and quasi peak detector in EMI receiver
- For ITE, emission limits are divided into Class A and Class B products
- Class B ITEs - intended primarily for use in the domestic environment; limits are more stringent
- Class A ITEs- all other ITE which satisfies the Class A ITE limits but not Class B; limits are more relaxed but a warning is required to be included in the instruction for use
- For CISPR 25, emission limits are divided into Class 1, 2, 3, 4 and 5 products
  
- In pre-compliance tests, the EMI receiver is typically replaced by a spectrum analyzer. In order to obtain similar results with a spectrum analyzer, settings such as resolution bandwidth, frequency span, sweep time and detectors need special consideration and will be treated separately in this document.

## Conducted emission limits - CISPR 11 1/4

Group 1 contains all ISM equipment in which there is intentionally generated and/or used conductively coupled radio-frequency energy which is necessary for the internal functioning of the equipment itself.

Group 2 contains all ISM equipment in which radio-frequency energy is intentionally generated and/or used in the form of electromagnetic radiation for the treatment of material, and spark erosion equipment.

Class A equipment is equipment suitable for use in all establishments other than domestic and those directly connected to a low voltage power supply network which supplies buildings used for domestic purposes. Class A equipment shall meet Class A limits.

Class B equipment is equipment suitable for use in domestic establishments and in establishments directly connected to a low voltage power supply network which supplies buildings used for domestic purposes.

Class B equipment shall meet class B limits.

Applicable Tekbox LISN for conducted measurements at mains terminals: **TBLC08**

# Conducted emission limits - CISPR 11 2/4

## Class A equipment

Frequency range	Class A equipment limits at mains terminals					
	Group 1		Group 2		Group 2*	
	Quasi Peak [dBµV]	Average [dBµV]	Quasi Peak [dBµV]	Average [dBµV]	Quasi Peak [dBµV]	Average [dBµV]
150 kHz - 500 kHz	79	66	100	90	130	120
500 kHz - 5 MHz	73	60	86	76	125	115
5 MHz - 30 MHz	73	60	Decreasing linearly with the logarithm of frequency from 90 to 73	Decreasing linearly with the logarithm of frequency from 80 to 60	115	105
* Mains supply currents in excess of 100 A per phase when using the CISPR voltage probe						

Applicable Tekbox LISN for conducted measurements at mains terminals: **TBLC08**

# Conducted emission limits - CISPR 11 3/4

## Class B equipment

Frequency range	Class B equipment limits at mains terminals	
	Group 1 and 2	
	Quasi Peak [dBµV]	Average [dBµV]
150 kHz - 500 kHz	Decreasing linearly with the logarithm of frequency from 66 to 56	Decreasing linearly with the logarithm of frequency from 56 to 46
500 kHz - 5 MHz	56	46
5 MHz - 30 MHz	60	50

Applicable Tekbox LISN for conducted measurements at mains terminals: **TBLC08**

# Conducted emission limits - CISPR 11 4/4

Induction cooking appliances for domestic and industrial use

Frequency range	Induction cooking appliance limits at mains terminals	
	Quasi Peak [dBµV]	Average [dBµV]
9 kHz - 50 kHz	110	none
50 kHz - 148.5 kHz	Decreasing linearly with the logarithm of frequency from 90 to 80	none
148.5 kHz - 500 kHz	Decreasing linearly with the logarithm of frequency from 66 to 56	Decreasing linearly with the logarithm of frequency from 56 to 46
500 kHz - 5 MHz	56	46
5 MHz - 30 MHz	60	50

Applicable Tekbox LISN for conducted measurements at mains terminals: **TBLC08**



## Conducted emission limits - CISPR 13

Sound and TV broadcast receivers and associated equipment

Frequency range	Limits at mains terminals	
	Quasi Peak [dB $\mu$ V]	Mittelwert [dB $\mu$ V]
150 kHz - 500 kHz	Decreasing linearly with the logarithm of frequency from 66 bis 56	Decreasing linearly with the logarithm of frequency from 56 bis 46
500 kHz - 5 MHz	56	46
5 MHz - 30 MHz	60	50

Applicable Tekbox LISN for conducted measurements at mains terminals: **TBLC08**

## Conducted emission limits - CISPR 14

Household appliances and equipment causing similar disturbances and regulating controls incorporating semiconductor devices

Frequency range	At mains terminals		At load terminals and additional terminals	
	Quasi Peak [dB $\mu$ V]	Average [dB $\mu$ V]	Quasi Peak [dB $\mu$ V]	Average [dB $\mu$ V]
150 kHz - 500 kHz	Decreasing linearly with the logarithm of frequency from 66 to 56	Decreasing linearly with the logarithm of frequency from 59 to 46	80	70
500 kHz - 5 MHz	56	46	74	64
5 MHz - 30 MHz	60	50	74	64

Applicable Tekbox LISN for conducted measurements at mains terminals: **TBLC08**

## Conducted emission limits - CISPR 14

### Mains terminals of tools

Frequency range	Rated motor power not exceeding 700W		Rated motor power from 700W to 1000W		Rated motor power above 1000W	
	Quasi Peak [dBµV]	Average [dBµV]	Quasi Peak [dBµV]	Average [dBµV]	Quasi Peak [dBµV]	Average [dBµV]
150 kHz - 350 kHz	Decreasing linearly with the logarithm of frequency from 66 to 59	Decreasing linearly with the logarithm of frequency from 59 to 49	Decreasing linearly with the logarithm of frequency from 70 to 63	Decreasing linearly with the logarithm of frequency from 63 to 53	Decreasing linearly with the logarithm of frequency from 76 to 69	Decreasing linearly with the logarithm of frequency from 69 to 59
350 kHz - 5 MHz	59	49	63	53	69	59
5 MHz - 30 MHz	64	54	68	58	74	64

Applicable Tekbox LISN for conducted measurements at mains terminals: **TBLC08**

## Conducted emission limits - CISPR 15

Mains terminals of lighting equipment

Frequency range	Quasi Peak [dB $\mu$ V]	Average [dB $\mu$ V]
9 kHz - 50 kHz	110	-
50 kHz - 150 kHz	Decreasing linearly with the logarithm of frequency from 90 to 80	-
150 kHz - 500 kHz	Decreasing linearly with the logarithm of frequency from 66 to 56	Decreasing linearly with the logarithm of frequency from 56 to 46
500 kHz - 5 MHz	56	46
5 MHz - 30 MHz	60	50

Applicable Tekbox LISN for conducted measurements at mains terminals: **TBLC08**

## Conducted emission limits - CISPR 22

Limits for conducted disturbance at the mains terminals of class A ITE

Frequency range	Quasi Peak [dB $\mu$ V]	Average [dB $\mu$ V]
150 kHz - 500 kHz	79	66
500 kHz - 30 MHz	73	60

Limits for conducted disturbance at the mains terminals of class B ITE

Frequency range	Quasi Peak [dB $\mu$ V]	Average [dB $\mu$ V]
150 kHz - 500 kHz	Decreasing linearly with the logarithm of frequency from 66 to 56	Decreasing linearly with the logarithm of frequency from 56 to 46
500 kHz - 5 MHz	56	46
5 MHz - 30 MHz	60	50

Applicable Tekbox LISN for conducted measurements at mains terminals: **TBLC08**

## Conducted emission limits - CISPR 25

Limits for conducted disturbance at the supply terminals of equipment on board of vehicles and boats - no LISN correction to be applied for below limits

### Peak and Quasi Peak limits

Class	Levels in dB(μV)											
	0.15 -0.3 MHz		0.53 - 1.8 MHz		5.9 - 6.2 MHz		26 - 41MHz		41 - 88 MHz		88 - 108 MHz	
	P	QP	P	QP	P	QP	P	QP	P	QP	P	QP
1	110	97	86	73	77	64	68	55	58	49	62	49
2	100	87	78	65	71	58	62	49	52	43	56	43
3	90	77	70	57	65	52	56	43	46	37	50	37
4	80	67	62	49	59	46	50	37	40	31	44	31
5	70	57	54	41	53	40	44	31	34	25	38	25

### AVG limits

Class	Levels in dB(μV)					
	0.15 -0.3 MHz	0.53 - 1.8 MHz	5.9 - 6.2 MHz	26 - 41MHz	41 - 88 MHz	88 - 108 MHz
1	90	66	57	48	42	42
2	80	58	51	42	36	36
3	70	50	45	36	30	30
4	60	42	39	30	24	24
5	50	34	33	24	28	28

Applicable Tekbox LISN for conducted measurements at mains terminals: 1 x TBOH01 or 2 x TBOH01

## Conducted emission limits - CISPR 32

Limits for conducted disturbance at the AC mains terminals of class A multimedia equipment

Frequency range	Quasi Peak [dB $\mu$ V]	Average [dB $\mu$ V]
150 kHz - 500 kHz	79	66
500 kHz - 30 MHz	73	60

Limits for conducted disturbance at the AC mains terminals of class B multimedia equipment

Frequency range	Quasi Peak [dB $\mu$ V]	Average [dB $\mu$ V]
150 kHz - 500 kHz	Decreasing linearly with the logarithm of frequency from 66 to 56	Decreasing linearly with the logarithm of frequency from 56 to 46
500 kHz - 5 MHz	56	46
5 MHz - 30 MHz	60	50

Applicable Tekbox LISN for conducted measurements at mains terminals: **TBLC08**

## Conducted emission test set up example - CISPR 16

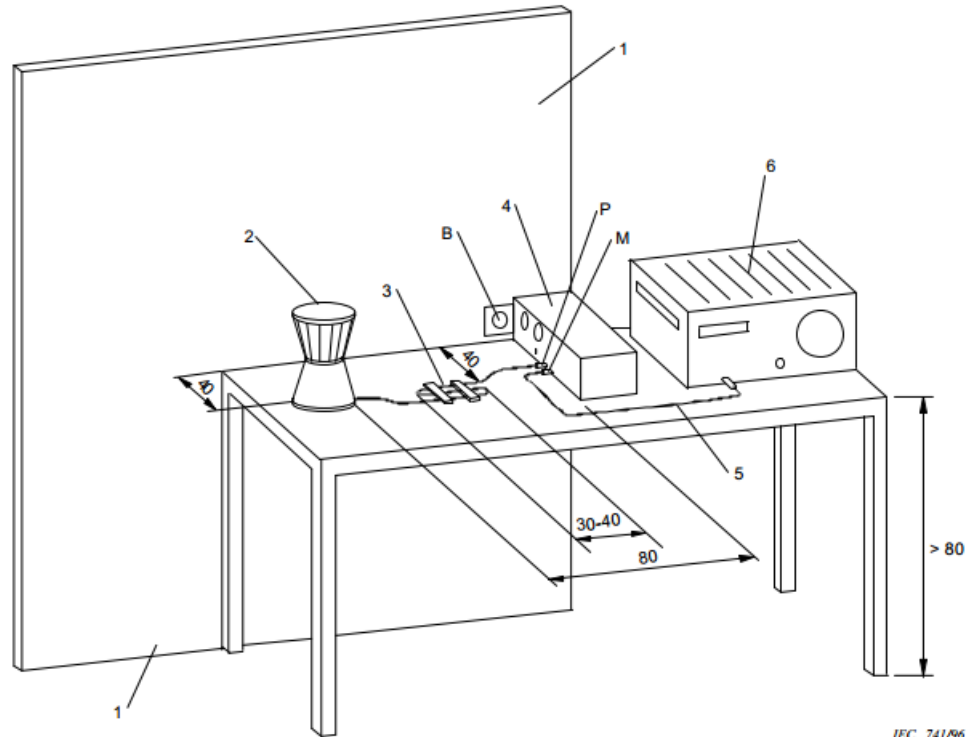

- 1 Metallic wall 2 m x 2 m
- 2 EUT
- 3 Excess power cord (3 cm x 40 cm) (folded back and forth)
- 4 "V" mains network
- 5 Coaxial cable
- 6 Measuring receiver
- B Reference ground connection
- M Measuring receiver input
- P Power to EUT

IEC 741/96

Measurement set up example taken from CISPR 16:  
 optional test configuration for an EUT with only a power cord attached  
 Note that this is only one out of many set ups for various type of equipment covered by CISPR 16

Applicable Tekbox LISN (=V-mains network) for conducted measurements at mains terminals: **TBLC08**



## Conducted emission pre-compliance test set up of mains powered equipment using the TBLC08 LISN

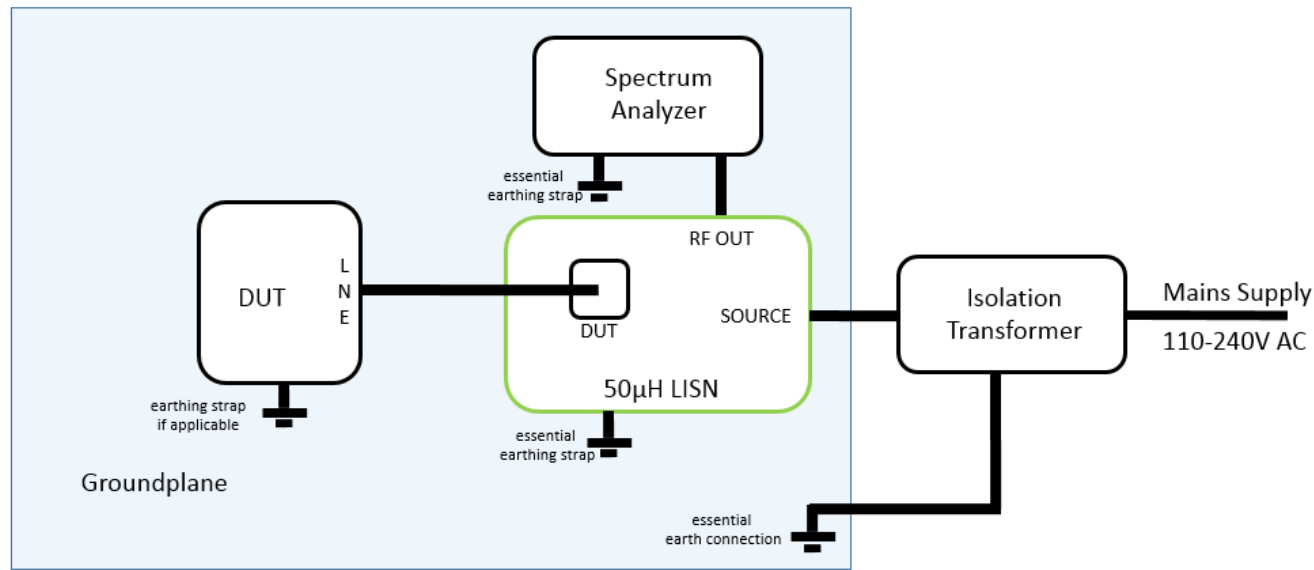

The DUT shall be isolated and elevated from the groundplane. The spectrum analyzer shall measure conducted emissions on both line and neutral.

The value of the parallel combination of the internal capacitors of the LISN is  $12\mu\text{F}$  from line and neutral to ground.

This causes a blind current of approximately  $0.75\text{A}$  flowing into the earth connection and would trip the ground fault switch.

**Hence, an insulation transformer is required and good grounding is essential for safety.**

# Conducted emission test set up examples - CISPR 25

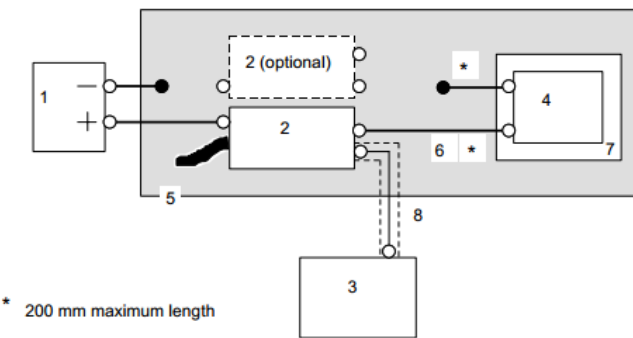
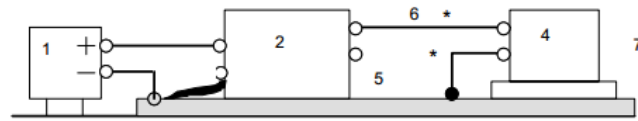

- 1 Power supply
- 2 Artificial mains network (one unit, second optional)/control box/loads
- 3 Measuring instrument
- 4 EUT
- 5 Ground plane
- 6 Test harness (power leads 200 mm maximum length)
- 7 Insulating spacer (50 mm thick), when required in test plan
- 8 Coaxial cable (50 Ω)

Figure 8 – Conducted emissions – EUT with power return line locally grounded

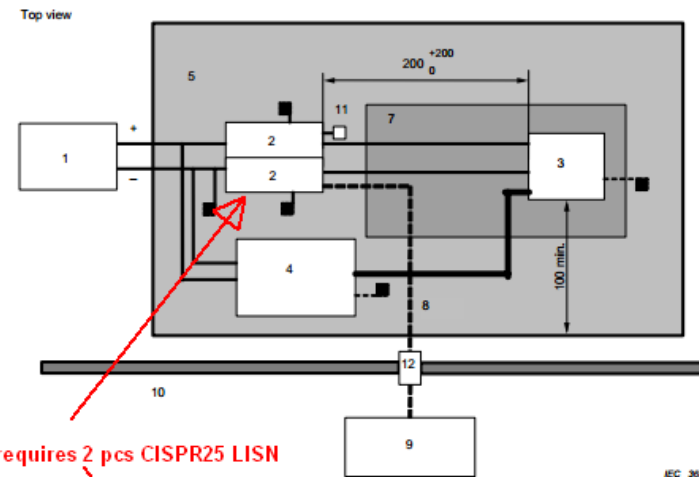
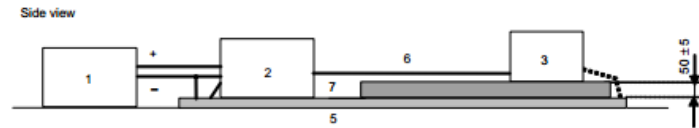

Key

- 1 Power supply (may be placed on the ground plane)
- 2 Artificial network
- 3 EUT (housing grounded if required in test plan)
- 4 Load simulator (metallic casing grounded if required in test plan)
- 5 Ground plane
- 6 Power supply lines
- 7 Low relative permittivity support ( $\epsilon_r \leq 1,4$ )
- 8 High-quality coaxial cable e.g. double-shielded (50 Ω)
- 9 Measuring instrument
- 10 Shielded enclosure
- 11 50 Ω load
- 12 Bulkhead connector

NOTE The EUT housing ground lead, when required in the test plan, should not be longer than 150 mm.

Figure 6 – Conducted emissions – EUT with power return line remotely grounded.

Applicable Tekbox LISN for conducted measurements at mains terminals: 1 x TBOH01 or 2 x TBOH01

# Conducted emission pre-compliance test set up of automotive equipment using TBOH01 5 $\mu$ H LISN

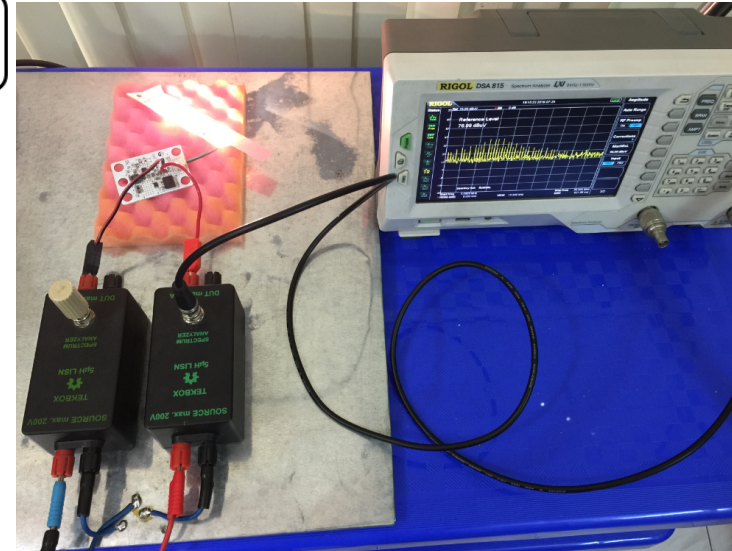
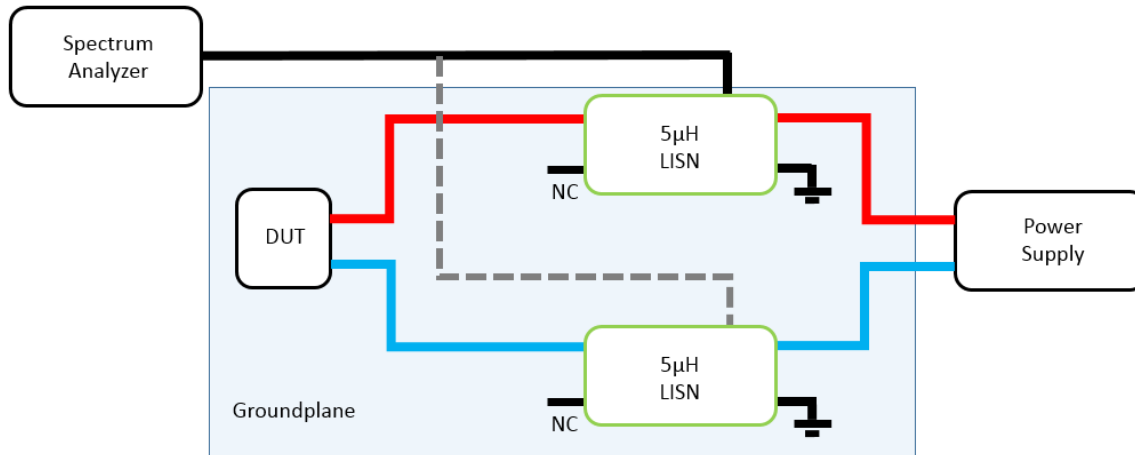

Example: conducted emission pre-compliance test of an automotive LED driver  
Using 2 pcs Tekbox TBOH01 5 $\mu$ H LISN

The DUT shall be isolated and elevated from the groundplane. The spectrum analyzer shall measure the conducted emissions on both supply lines. The RF output of the unused LISN shall be terminated with 50 Ohm. In case of a DUT with locally grounded return line, a set up with a single LISN is sufficient.

# Recommended spectrum analyzer settings for conducted emission measurements



## Recommended settings for Rigol DSA815

Frequency range	Specified resolution bandwidth for conducted emission measurements	Maximum sub-band span	Min. sweep time		
			Average detector	Peak detector	Quasi peak detector
9 kHz -150 kHz	200 Hz	60 kHz	5 s	5 s	1200 s
150 kHz - 30 MHz	9 kHz	2.7 MHz	10 s/MHz	10 s/MHz	200 s/MHz
30 MHz - 108 MHz	120 kHz	36 MHz	100 ms/MHz	100 ms/MHz	20 s/MHz

As an example for a spectrum analyzer, the Rigol DSA815 has 601 discrete sweep points across the selected sweep range. In order to ensure that no spurious can be missed, the RBW windows of two adjacent frequency points should sufficiently overlap. A good choice for a RBW of 200Hz is to choose frequency steps of 100Hz. Similarly at a RBW of 9kHz, frequency steps of 4.5k Hz are appropriate. A sweep of the Rigol DSA 815 consists of 601 discrete frequency points.

The resulting spans recommended for conducted emission measurements using the Rigol DSA815 are  $600 * 100 \text{ Hz} = 60 \text{ kHz}$  in the frequency range 9 kHz to 150 kHz and  $600 * 4.5 \text{ kHz} = 2.7 \text{ MHz}$  in the frequency range 150 kHz to 30 MHz.

Hence, the frequency range 9kHz - 150 kHz where the standards specifies 200 Hz RBW should be divided in 3 sub bands with a sweep range of: 9kHz - 50kHz, 50kHz - 100kHz, 100kHz - 150kHz. Similarly, for the frequency bands above 150kHz, the measurement should be split into sections with a maximum span of 2.7 MHz.

## Where to obtain standards:

Standards can be obtained in the web shops of national standardization institutes and various other sellers in the internet.

There are also free sources as some countries provide free access to national standards which often are adopted CISPR standards. They may however not always match the latest edition of the relevant base standards.

For example:

<https://law.resource.org/pub/in/bis/manifest.litd.9.html>

Further information on [www.tekbox.net](http://www.tekbox.net)