

RIGOL

User's Guide

M300 Series Data Acquisition/Switch System

**May 2015
RIGOL Technologies, Inc.**

Guaranty and Declaration

Copyright

© 2013 RIGOL Technologies, Inc. All Rights Reserved.

Trademark Information

RIGOL is a registered trademark of RIGOL Technologies, Inc.

Publication Number

UGC07111-1110

Software Version

00.02.00.04.19

Software upgrade might change or add product features. Please acquire the latest version of the manual from **RIGOL** website or contact **RIGOL** to upgrade the software.

Notices

- **RIGOL** products are covered by P.R.C. and foreign patents, issued and pending.
- **RIGOL** reserves the right to modify or change parts of or all the specifications and pricing policies at company's sole decision.
- Information in this publication replaces all previously corresponding material.
- Information in this publication is subject to change without notice.
- **RIGOL** shall not be liable for either incidental or consequential losses in connection with the furnishing, use or performance of this manual as well as any information contained.
- Any part of this document is forbidden to be copied, photocopied or rearranged without prior written approval of **RIGOL**.

Product Certification

RIGOL guarantees this product conforms to the national and industrial standards in China as well as the ISO9001:2008 standard and the ISO14001:2004 standard. Other international standard conformance certifications are in progress.

Contact Us

If you have any problem or requirement when using our products or this manual, please contact **RIGOL**.

E-mail: service@rigol.com

Website: www.rigol.com

Safety Requirement

General Safety Summary

Please review the following safety precautions carefully before putting the instrument into operation so as to avoid any personal injury or damage to the instrument and any product connected to it. To prevent potential hazards, please use the instrument only specified by this manual.

Use Proper Power Cord.

Only the power cord designed for the instrument and authorized for use within the local country could be used.

Ground the Instrument.

The instrument is grounded through the Protective Earth lead of the power cord. To avoid electric shock, it is essential to connect the earth terminal of the power cord to the Protective Earth terminal before connecting any inputs or outputs.

Connect the Probe Correctly.

If a probe is used, do not connect the ground lead to high voltage since it has isobaric electric potential as the ground.

Observe All Terminal Ratings.

To avoid fire or shock hazard, observe all ratings and markers on the instrument and check your manual for more information about ratings before connecting the instrument.

Use Proper Overvoltage Protection.

Make sure that no overvoltage (such as that caused by a thunderstorm) can reach the product, or else the operator might be exposed to the danger of electrical shock.

Do Not Operate Without Covers.

Do not operate the instrument with covers or panels removed.

Do Not Insert Anything Into the Holes of Fan.

Do not insert anything into the holes of the fan to avoid damaging the instrument.

Use Proper Fuse.

Please use the specified fuses.

Avoid Circuit or Wire Exposure.

Do not touch exposed junctions and components when the unit is powered.

Do Not Operate With Suspected Failures.

If you suspect damage occurs to the instrument, have it inspected by **RIGOL** authorized personnel before further operations. Any maintenance, adjustment or replacement especially to circuits or accessories must be performed by **RIGOL** authorized personnel.

Keep Well Ventilation.

Inadequate ventilation may cause an increase of instrument temperature which would cause damage to the instrument. So please keep the instrument well ventilated and inspect the intake and fan regularly.

Do Not Operate in Wet Conditions.

In order to avoid short circuiting to the interior of the device or electric shock, please do not operate the instrument in a humid environment.

Do Not Operate in an Explosive Atmosphere.

In order to avoid damage to the device or personal injuries, it is important to operate the device away from an explosive atmosphere.

Keep Product Surfaces Clean and Dry.

To avoid the influence of dust and/or moisture in the air, please keep the surface of the device clean and dry.

Electrostatic Prevention.

Operate the instrument in an electrostatic discharge protective environment to avoid damage induced by static discharges. Always ground both the internal and external conductors of cables to release static before making connections.

Proper Use of Battery.

If a battery is supplied, it must not be exposed to high temperature or in contact with fire. Keep it out of the reach of children. Improper change of battery (note: lithium battery) may cause explosion. Use **RIGOL** specified battery only.

Handling Safety.

Please handle with care during transportation to avoid damage to keys, knob interfaces and other parts on the panels.

Safety Terms and Symbols

Terms Used in this Manual. These terms may appear in this manual:



WARNING

Warning statements indicate conditions or practices that could result in injury or loss of life.



CAUTION

Caution statements indicate conditions or practices that could result in damage to this product or other property.

Terms Used on the Product. These terms may appear on the Product:

DANGER It calls attention to an operation, if not correctly performed, could result in injury or hazard immediately.

WARNING It calls attention to an operation, if not correctly performed, could result in potential injury or hazard.

CAUTION It calls attention to an operation, if not correctly performed, could result in damage to the product or other devices connected to the product.

Symbols Used on the Product. These symbols may appear on the product:



**Hazardous
Voltage**



**Safety
Warning**



**Protective
Earth
Terminal**



**Chassis
Ground**



**Test
Ground**

Allgemeine Sicherheits Informationen

Überprüfen Sie die folgenden Sicherheitshinweise sorgfältig um Personenschäden oder Schäden am Gerät und an damit verbundenen weiteren Geräten zu vermeiden. Zur Vermeidung von Gefahren, nutzen Sie bitte das Gerät nur so, wie in diesem Handbuch angegeben.

Um Feuer oder Verletzungen zu vermeiden, verwenden Sie ein ordnungsgemäßes Netzkabel.

Verwenden Sie für dieses Gerät nur das für ihr Land zugelassene und genehmigte Netzkabel.

Erden des Gerätes.

Das Gerät ist durch den Schutzleiter im Netzkabel geerdet. Um Gefahren durch elektrischen Schlag zu vermeiden, ist es unerlässlich, die Erdung durchzuführen. Erst dann dürfen weitere Ein- oder Ausgänge verbunden werden.

Anschluss eines Tastkopfes.

Die Erdungsklemmen der Sonden sind auf dem gleichen Spannungspegel des Instruments geerdet. Schließen Sie die Erdungsklemmen an keine hohe Spannung an.

Beachten Sie alle Anschlüsse.

Zur Vermeidung von Feuer oder Stromschlag, beachten Sie alle Bemerkungen und Markierungen auf dem Instrument. Befolgen Sie die Bedienungsanleitung für weitere Informationen, bevor Sie weitere Anschlüsse an das Instrument legen.

Verwenden Sie einen geeigneten Überspannungsschutz.

Stellen Sie sicher, daß keinerlei Überspannung (wie z.B. durch Gewitter verursacht) das Gerät erreichen kann. Andernfalls besteht für den Anwender die Gefahr eines Stromschlages.

Nicht ohne Abdeckung einschalten.

Betreiben Sie das Gerät nicht mit entfernten Gehäuse-Abdeckungen.

Betreiben Sie das Gerät nicht geöffnet.

Der Betrieb mit offenen oder entfernten Gehäuseteilen ist nicht zulässig. Nichts in entsprechende Öffnungen stecken (Lüfter z.B.)

Passende Sicherung verwenden.

Setzen Sie nur die spezifikationsgemäßen Sicherungen ein.

Vermeiden Sie ungeschützte Verbindungen.

Berühren Sie keine unisolierten Verbindungen oder Baugruppen, während das Gerät

in Betrieb ist.

Betreiben Sie das Gerät nicht im Fehlerfall.

Wenn Sie am Gerät einen Defekt vermuten, sorgen Sie dafür, bevor Sie das Gerät wieder betreiben, dass eine Untersuchung durch **RIGOL** autorisiertem Personal durchgeführt wird. Jedwede Wartung, Einstellarbeiten oder Austausch von Teilen am Gerät, sowie am Zubehör dürfen nur von **RIGOL** autorisiertem Personal durchgeführt werden.

Belüftung sicherstellen.

Unzureichende Belüftung kann zu Temperaturanstiegen und somit zu thermischen Schäden am Gerät führen. Stellen Sie deswegen die Belüftung sicher und kontrollieren regelmäßig Lüfter und Belüftungsöffnungen.

Nicht in feuchter Umgebung betreiben.

Zur Vermeidung von Kurzschluß im Geräteinneren und Stromschlag betreiben Sie das Gerät bitte niemals in feuchter Umgebung.

Nicht in explosiver Atmosphäre betreiben.

Zur Vermeidung von Personen- und Sachschäden ist es unumgänglich, das Gerät ausschließlich fernab jedweder explosiven Atmosphäre zu betreiben.

Geräteoberflächen sauber und trocken halten.

Um den Einfluß von Staub und Feuchtigkeit aus der Luft auszuschließen, halten Sie bitte die Geräteoberflächen sauber und trocken.

Schutz gegen elektrostatische Entladung (ESD).

Sorgen Sie für eine elektrostatisch geschützte Umgebung, um somit Schäden und Funktionsstörungen durch ESD zu vermeiden. Erden Sie vor dem Anschluß immer Innen- und Außenleiter der Verbindungsleitung, um statische Aufladung zu entladen.

Die richtige Verwendung des Akku.

Wenn eine Batterie verwendet wird, vermeiden Sie hohe Temperaturen bzw. Feuer ausgesetzt werden. Bewahren Sie es außerhalb der Reichweite von Kindern auf. Unsachgemäße Änderung der Batterie (Anmerkung: Lithium-Batterie) kann zu einer Explosion führen. Verwenden Sie nur von **RIGOL** angegebenen Akkus.

Sicherer Transport.

Transportieren Sie das Gerät sorgfältig (Verpackung!), um Schäden an Bedienelementen, Anschlüssen und anderen Teilen zu vermeiden.

Sicherheits Begriffe und Symbole

Begriffe in diesem Guide. Diese Begriffe können in diesem Handbuch auftauchen:



WARNING

Die Kennzeichnung WARNING beschreibt Gefahrenquellen die leibliche Schäden oder den Tod von Personen zur Folge haben können.



CAUTION

Die Kennzeichnung Caution (Vorsicht) beschreibt Gefahrenquellen die Schäden am Gerät hervorrufen können.

Begriffe auf dem Produkt. Diese Bedingungen können auf dem Produkt erscheinen:

- DANGER** weist auf eine Verletzung oder Gefährdung hin, die sofort geschehen kann.
- WARNING** weist auf eine Verletzung oder Gefährdung hin, die möglicherweise nicht sofort geschehen.
- CAUTION** weist auf eine Verletzung oder Gefährdung hin und bedeutet, dass eine mögliche Beschädigung des Instruments oder anderer Gegenstände auftreten kann.

Symbole auf dem Produkt. Diese Symbole können auf dem Produkt erscheinen:



GefährlicheS
pannung



Sicherheits-
Hinweis



Schutz-erde



Gehäusemasse



Erde

General Care and Cleaning

General Care

Do not store or leave the instrument where it may be exposed to direct sunlight for long periods of time.

Cleaning

Clean the instrument regularly according to its operating conditions. To clean the exterior surface, perform the following steps:

1. Disconnect the instrument from all power sources.
2. Clean the loose dust on the outside of the instrument with a lint-free cloth (with a mild detergent or water). When cleaning the LCD, take care to avoid scarifying it.



CAUTION

To avoid damage to the instrument, do not expose it to caustic liquids.



WARNING

To avoid short-circuit and personal injury resulting from moisture, make sure the instrument is completely dry before reconnecting it to power supply.

Environmental Considerations

The following symbol indicates that this product complies with the applicable WEEE Directive 2002/96/EC.



Product End-of-Life Handling

The equipment may contain substances that could be harmful to the environment or human health. In order to avoid release of such substances into the environment and harm to human health, we encourage you to recycle this product in an appropriate system that will ensure that most of the materials are reused or recycled appropriately. Please contact your local authorities for disposal or recycling information.

M300 Overview

The M300 series data acquisition/switch system provides 5 slots to accept any combination of 8 kinds of plug-in modules, including a DMM module, multiple multiplexers, an actuator, a matrix switch module and a multifunction module. With its modular structure, it combines precision measurement capability with flexible signal connections and can provide versatile solutions for the applications that require multiple points or signals to be tested. This can be especially useful in product performance testing during the R&D phase, and automatic test during production process.

It comes with a 4.3 inch high-resolution color LCD, user-friendly interface design, easy-to-use keyboard layout as well as clear key backlight and operation prompts. The M300 is extremely flexible and easy to use. For remote control versatility, it comes with RS232, USB, LAN and GPIB interfaces standard.

Main Features:

- Up to 320 switch channels per mainframe (with very low cost per channel)
- Can run independently without PC
- USB data logging
- Interval scanning with storage of up to 100,000 time-stamped readings
- 8 modules supported
- 6½ digit DMM can be inserted into any slot. It also supports multiple measurement functions, including DCV, DCI, ACV, ACI, 2WR, 4WR, PERIOD, FREQ, TEMP (Thermocouple, Thermistor and RTD) and any sensor.
- Standard multiple communication interface: USB Device, USB Host, GPIB, LAN(LXI Core 2011 Device) and RS232
- Standard SCPI commands for remote programming capability
- Math statistics function: AVG, MAX, MIN and SDEV
- Friendly interface
- Built-in help system
- Multiple system language
- 4.3 inch color LCD
- PC control and analysis software

Document Overview

Main topics in this manual:

Chapter 1 Quick Guide

This chapter introduces the front panel, rear panel, user interface and plug-in modules of the M300 as well as the precautions when using it for the first time.

Chapter 2 Front Panel Operations

This chapter introduces in details the front panel operation methods and functions of M300.

Chapter 3 To Use External DMM

This chapter illustrates the method of connecting external DMM and configuring scan list to scan.

Chapter 4 Remote Control

This chapter introduces how to control the M300 remotely.

Chapter 5 Troubleshooting

This chapter introduces the commonly encountered failures and their solutions.

Chapter 6 Specifications

This chapter provides the performance specifications and general technical parameters of the M300.

Chapter 7 Appendix

This chapter provides the accessory list of the M300 as well as service and support information.

Format Conventions in this Manual:

1. Key:

The front panel key is denoted by the format of "Text Box + Key Name (Bold)". For example, **Utility** denotes the **Utility** key.

2. Menu:

The menu is denoted by the format of "Character Shading + Menu Word (Bold)". For example, **System** denotes the system menu item of the **Utility** function key.

3. Operation Step:

The next step of operation is denoted by an arrow "→". For example, **Utility** → **System** denotes pressing **Utility** at the front panel and then pressing **System**.

User Manuals of This Product:

The main user manuals of this product include the Quick Guide, User's Guide, Programming Guide and Data sheet. Users can download the desired manual from www.rigol.com.

Contents

Guaranty and Declaration	I
Safety Requirement	II
General Safety Summary.....	II
Safety Terms and Symbols	V
Allgemeine Sicherheits Informationen.....	VI
Sicherheits Begriffe und Symbole	VIII
General Care and Cleaning	IX
Environmental Considerations.....	IX
M300 Overview	X
Document Overview.....	XI
Chapter 1 Quick Guide.....	1-1
General Inspection	1-2
Appearance and Dimensions.....	1-3
Front Panel	1-4
Rear Panel	1-8
Power On Inspection	1-12
User Interface.....	1-13
To Input Filename	1-14
Plug-in Module Overview.....	1-16
Outside View Drawing of the Module.....	1-16
Insert the Module into the Mainframe	1-17
Module Overview	1-18
To Use the Built-in Help System	1-20
Measurement Connections	1-21
To Replace the Fuse	1-25
Menu Quick Navigation	1-26
Config	1-26
Monitor	1-27
View Switch Key	1-27
Control	1-28
Alarm Channel Setting Keys	1-28
Chapter 2 Front Panel Operations	2-1
Scan Configuration	2-2
Scan List.....	2-2
Trigger Mode.....	2-8
Channel Configuration.....	2-12
Channel Configuration When Using External DMM.....	2-21
Measurement Parameter Configuration	2-22
Digital Input.....	2-35
Totalizer.....	2-37

Configuration Copy	2-39
Channel Monitor	2-44
Single-channel Monitor	2-44
Multi-channel Monitor	2-46
All Channel Monitor	2-46
Module Control	2-47
To Control MC3120	2-48
To Control MC3132	2-51
To Control MC3164	2-54
To Control MC3324	2-56
To Control MC3416	2-59
To Control MC3534	2-61
To Control MC3648	2-64
Alarm Channel Setting	2-66
View Switch	2-68
Scan History Information	2-68
Channel Status Table	2-70
Measurement Curve	2-70
Channel Information	2-72
Store and Recall	2-73
File Type	2-74
Internal Storage	2-75
External Storage	2-75
To Save a File	2-76
Utility	2-77
System Setting	2-78
I/O Configuration	2-86
System Information	2-92
Detect	2-92
System Update	2-93
Chapter 3 To Use External DMM	3-1
To Connect Instruments	3-2
To Configure the Instruments	3-4
Scan Control Method	3-5
Chapter 4 Remote Control	4-1
User-defined Programming	4-2
To Use PC Software	4-6
To Control M300 through GPIB	4-6
To Control M300 through USB	4-8
To Control M300 through RS232	4-9
To Control M300 through LAN	4-11
Chapter 5 Troubleshooting	5-1
Chapter 6 Specifications	6-1
DC Characteristics	6-1

AC Characteristics.....	6-3
Frequency and Period Characteristics	6-6
Temperature Characteristics	6-8
Module Specifications	6-10
MC3120/MC3132/MC3164/MC3324/MC3416/MC3648	6-10
MC3534	6-12
General Specifications.....	6-13
Chapter 7 Appendix	7-1
Appendix A: Accessories and Options List	7-1
Appendix B: Definitions of the Pins of the 78-pin Interface of the Plug-in Modules	7-2
MC3120	7-2
MC3132	7-3
MC3164	7-4
MC3324	7-5
MC3416	7-6
MC3534	7-7
MC3648	7-8
Appendix B: Warranty	7-9
Index	1

Chapter 1 Quick Guide

This chapter guides users to quickly get familiar with the front/rear panels, user interface as well as the measurement connections of the M300.

Topics in this chapter:

- General Inspection
- Appearance and Dimensions
- Front Panel
- Rear Panel
- Power On Inspection
- User Interface
- To Input Filename
- Plug-in Module Overview
- To Use the Built-in Help System
- Measurement Connections
- To Replace the Fuse
- Menu Quick Navigation

General Inspection

1. Inspect the shipping container for damage.

Keep the damaged shipping container or cushioning material until the contents of the shipment have been checked for completeness and the instrument has passed both electrical and mechanical tests.

The consigner or carrier shall be liable for the damage to instrument resulting from shipment. **RIGOL** would not be responsible for free maintenance/rework or replacement of the unit.

2. Inspect the instrument.

In case of any damage, or defect, or failure, notify your **RIGOL** sales representative.

3. Check the Accessories

Please check the accessories according to the packing lists. If the accessories are incomplete or damaged, please contact your **RIGOL** sales representative.

Appearance and Dimensions

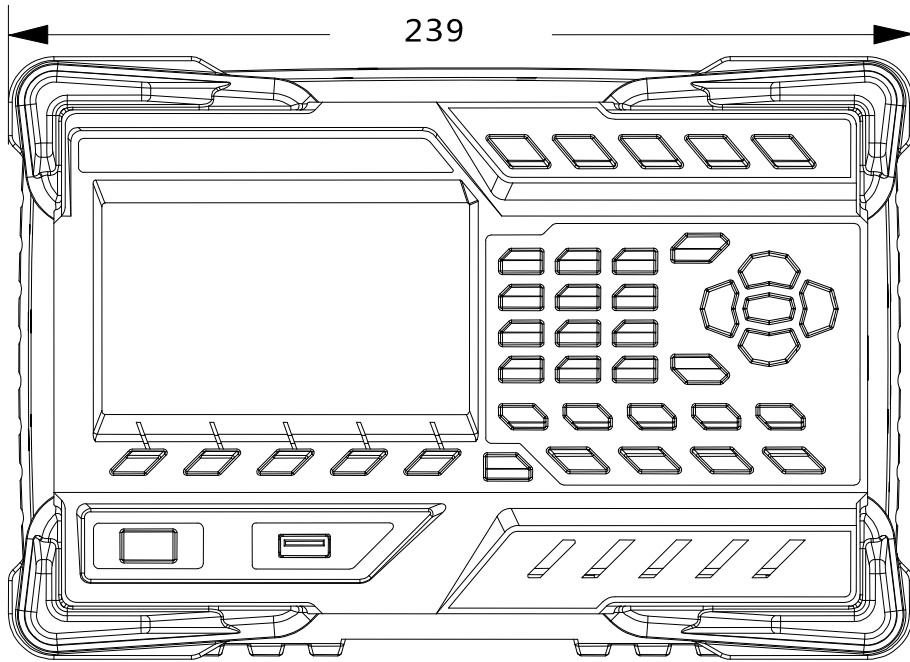

Figure 1-1 Front View (Unit: mm)

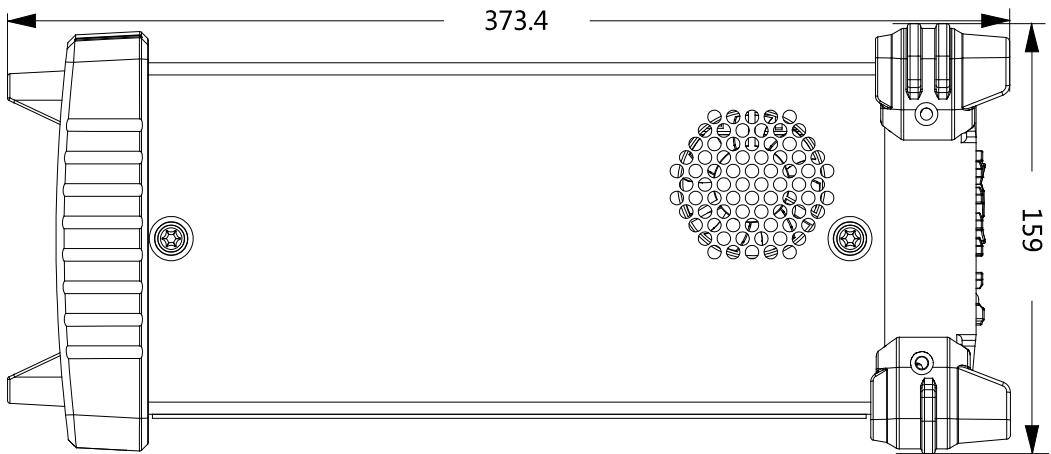

Figure 1-2 Side View (Unit: mm)

Front Panel

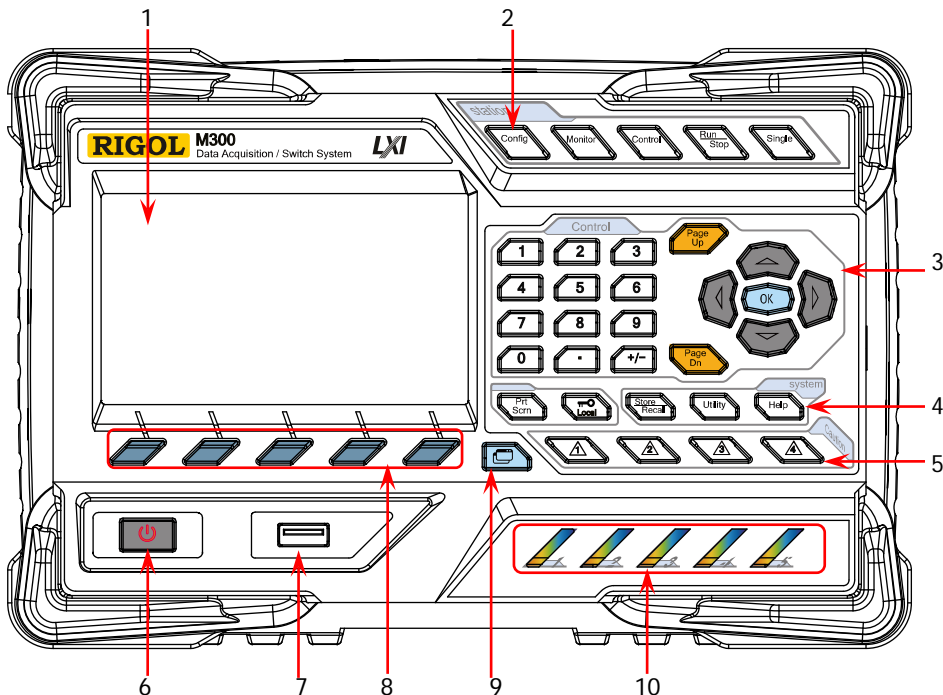

Figure 1-3 Front Panel of M300

1 LCD

4.3 inches high-resolution color LCD displaying the menu, configuration guide, measurement parameters, system status and prompt messages.

2 Function Keys



Configure the scan list and the measurement parameters of each channel.

- Create, edit, read and save the scan list.
- Set the number of scans, trigger mode and scan interval.
- Provide the channel configuration guide used to configure the measurement parameters, scaling parameters, alarm parameters and advanced measurement parameters of the channel.



Enable or disable the channel monitor function.

- Support single-channel, multi-channel and all-channel monitor functions.
- In single-channel monitor function, you can switch the channel monitored at any time.
- In multi-channel monitor function, you can monitor up to 7 channels in the scan list.

- In all-channel monitor function, you can monitor all the channels in the scan list.



Control the modules currently inserted.

- Control the status of each channel of the modules.
- Reset the modules.
- Configure the DIO and TOT channels of multifunction module.
- Can not control the DMM module.



Auto Trigger/Stop

Press this key, the instrument triggers or enters the wait-for-trigger state and the backlight goes on. Press and hold this key, the instrument stops triggering or exits the wait-for-trigger state and the backlight goes off.

Note: This key is invalid when the scan list is empty.



Single-channel Switch

When the instrument is in the single-channel monitor interface, press this key to switch the channel monitored to the next channel in the scan list. When the instrument is in other interfaces, press this key to switch the instrument to the single-channel monitor interface.

3 Control Keys

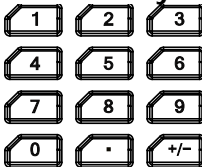

Numeric Keyboard

- Include numbers (0-9), decimal point (.) as well as positive/negative signs (+/-).
- Used to input parameter value, date and time.



Use this key to open the previous or next page of the current interface.

Note: These keys are different from the menu page up and down keys (**Page Up** and **Page Dn**).

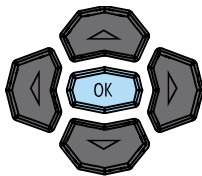

Direction keys and confirmation key.

4 System Keys



If a USB storage device is currently connected to the instrument, press this key to store the current content on the screen in USB storage device in *.bmp format.



- When the instrument is in local mode, pressing this key can lock the front panel. At this point, all the keys at the front panel except this key become invalid. Press and hold this key to unlock the front panel.
- When the instrument is in remote mode, press this key to switch to local mode.



Store and recall the system configuration, measurement configuration and measurement data, etc.

- Store the file in the internal non-volatile memory or external USB storage device.
- Read the file stored.



Configure the system-related parameters.

- Set various parameters such as the time, date, system language and display brightness.
- Configure the remote interface parameters: RS232, LAN, GPIB and USB.
- Query the system information (such as the model and serial number).
- Execute self-test and view the information of each module (such as the name and model of the module).
- System update.



Enable the built-in help system. Provide Chinese/English help information for the front panel function keys and menu items.

5 Alarm Channel Setting



M300 provides 4 alarm channels. When an alarm is generated, the corresponding pin of the Alarms/Ext Trig interface (converted from the **[RS-232/Alarms/Ext Trig]** interface) at the rear panel outputs a pulse. You can press the corresponding key to set the output mode of the corresponding pin.

6 Power Key



Press this key to turn on or off the instrument.

7 USB Host



Via this interface, M300 can be as a host device and connected with an USB storage device to store or recall instrument status, measurement configuration, measurement data, etc.

8 Menu Softkeys

Correspond to the menus on the screen. Pressing any softkey can enable the corresponding menu.

9 View Switch

View the scan history information, channel status table, measurement curve and channel information.

- Scan history information: view the start time, scan sweep, count, channel number as well as the corresponding function, maximum, minimum, average and standard deviation measured and the scan readings of each channel of the latest scan.



- Channel status table: display the current status of each channel.
- Measurement curve: display the measurement curve of the specified channel.
- Channel information: view the cycle count of each relay of the module, the alarm messages of the current scan (the first 100, including the reading and time when the alarm is generated) and error messages (up to 20).

Note: Up to 100 alarm messages on each alarm channel can be logged in the alarm queue and the other alarm messages would be lost and up to 20 error messages can be logged in the error queue and the other error messages will also be lost.

10 Module Indicators

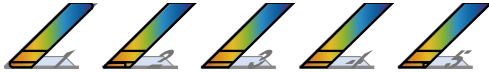

Correspond to the 5 module slots at the rear panel respectively. The corresponding module indicator goes on when the module is inserted into the slot at the rear panel.

Rear Panel

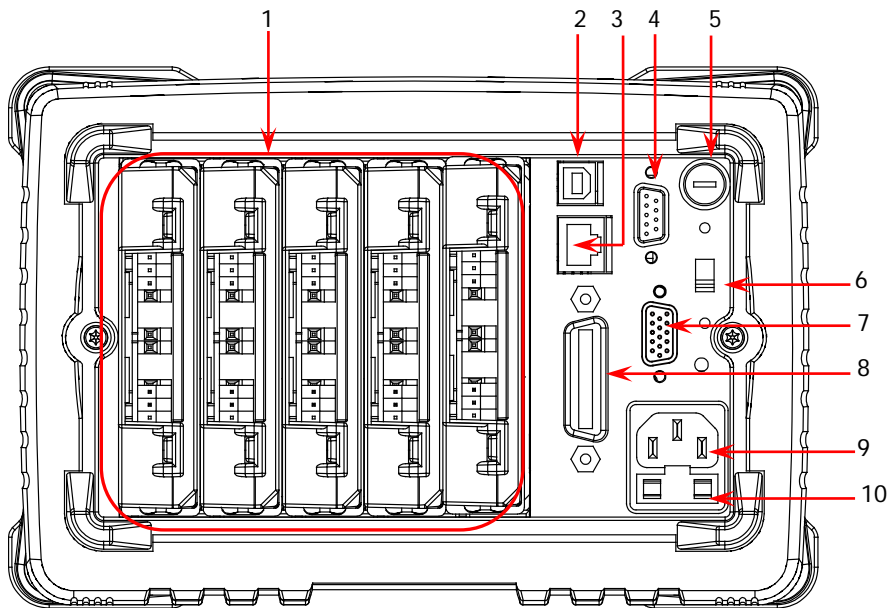

Figure 1-4 Rear Panel of M300

1 Slots

The M300 provides 5 slots for 5 modules. The 5 slots from left to right in the figure above correspond to the 5 module indicators at the front panel respectively. When a module is inserted in the slot, the corresponding module indicator at the front panel goes on. Figure 1-4 is the schematic diagram of the rear panel without the modules inserted. For information of each module, refer to “**Plug-in Module Overview**”.



CAUTION

Only one DMM module is permitted for one mainframe.

2 USB Device

Via this interface, M300 can communicate with the PC as a slave device and you can control it remotely via the PC.

3 LAN

M300 conforms to the LXI Core 2011 Device standard. The instrument can be connected to the network via this interface and you can control the instrument remotely via a PC in the same network.

4 Analog Bus Interface (Female)

M300 provides two internal 2-wire analog buses for signal routing as well as an

external interface (namely Analog Bus Interface). The analog bus interface is a 9-pin female interface.

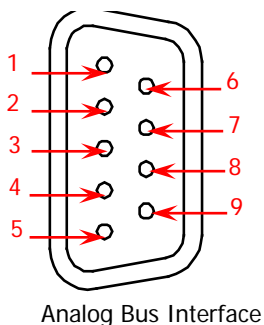

Pin	Definition
1	Current Input
2	Lo
3	LoSense
4	--
5	--
6	Hi
7	HiSense
8	Float GND
9	--

5 DMM Module Power Fuse

The AC power supply from the power socket is divided into two paths with one for the DMM module and the other for other circuits except the DMM module. M300 is equipped with the DMM module power fuse (AC 250V T250 mA). To replace the fuse, refer to the method below.

- 1) Turn off the instrument and remove the power cord.
- 2) Press down the fuse cover using a straight screw driver and rotate clockwise.
- 3) Select a proper voltage through the voltage selector.
- 4) Disassemble the fuse cap and fuse.
- 5) Replace a specified fuse and install the fuse cap.



CAUTION

Please use the specified fuse to avoid electric shock and fire.

6 Voltage Selector

M300 supports two kinds of AC voltages (115 V and 230 V). Please select the proper voltage scale according to the AC power used.

7 RS-232/Alarms/Ext Trig Mixed Interface (Male)

This interface is a 15-pin male interface. The definitions of the pins are as shown in the table below.

Pin	Function	Pin	Function		
1	Alarm1	Output	9	PC_RX	Output
2	Alarm2	Output	10	PC_DSR	Output
3	Alarm3	Output	11	GND	--
4	Alarm4	Output	12	PC_DTR	Input
5	CH Close	Output	13	PC_CTS	Output
6	Trig	Input	14	PC_RTS	Input
7	GND	--	15	NC	--
8	PC_TX	Input	--	--	--

You can convert this interface into two 9-pin interfaces using the Mixed Interface Convert Cable (accessory). This breakout cable consists of a 9-pin male interface used as a standard RS232 interface and a 9-pin female interface used for alarm output, external trigger signal input and etc.

- RS232: via this interface, M300 can communicate with the PC and you can control the instrument remotely via the PC.

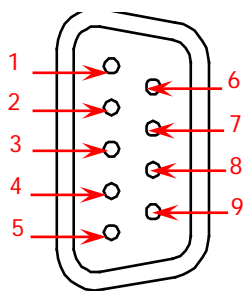

RS232 Interface

Pin	Name	Definition
1	--	--
2	RXD	Received Data
3	TXD	Transmitted Data
4	DTR	Data Terminal Ready
5	SGND	Signal Ground
6	DSR	Data Set Ready
7	RTS	Request To Send
8	CTS	Clear To Send
9	--	--

- Alarms/Ext Trig: as shown in the figure below, pin 1 to pin 4 are used to output TTL pulse when an alarm is generated in the corresponding alarm channel. Pin 6 is used to receive external trigger signal. When an external digital multimeter is connected for measurement, pin 5 and pin 6 are used together to control the measurement.

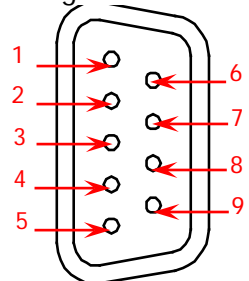

Alarms/Ext Trig Interface

Pin	Definition
1	Alarm 1 Output
2	Alarm 2 Output
3	Alarm 3 Output
4	Alarm 4 Output
5	Channel Closed Output
6	Ext Trig Input/Channel Advance Input
7	GND
8	--
9	--

Note:

The Pin 5 outputs a TTL negative pulse with about 7 μ s pulse width each time the measurement is completed. The output rate is dependent upon the actual measurement rate. The maximum output rate is 1000 times per second.

In external trigger mode, Pin 6 accepts external trigger signal. The trigger can have a pulse width equal to or greater than 2 μ s with specified edge. To configure, press **Config**, select "External" trigger mode and select "Rising" or "Falling" in **Edge** item. If the external trigger signal is continuous pulse, please make sure the pulse period is larger than 100 μ s.

8 GPIB

The M300 conforms to the IEEE-488.2 standard. Via this interface, the M300 can be controlled remotely via a PC with a GPIB interface.

9 Power Socket

The M300 can accept two kinds of AC power supplies. Use the power cord provided in the accessories to connect the AC power supply to the instrument via this socket.

**CAUTION**

Before connecting the AC power supply, select the correct voltage scale using the **voltage selector**.

10 Power Fuse

The specification of the fuse of M300 is AC 250V T3.15 A. If a new fuse is required, please refer to "**To Replace the Fuse**".

**CAUTION**

Please use the specified power fuse and make sure that the fuse seat is not short-circuited to avoid electric shock and fire.

Power On Inspection

1 Connect the power

- (1) Adjust the power voltage selector at the rear panel according to the power supply voltage. M300 supports two types of AC power. If your supply voltage is in the range of $115 \times (100\% - 10\%) \text{ V}$ and $115 \times (100\% + 10\%) \text{ V}$, please select 115 and if it is in the range of $230 \times (100\% - 10\%) \text{ V}$ and $230 \times (100\% + 10\%) \text{ V}$, please select 230.
- (2) Connect the instrument to AC power using the power cord provided in the accessories.

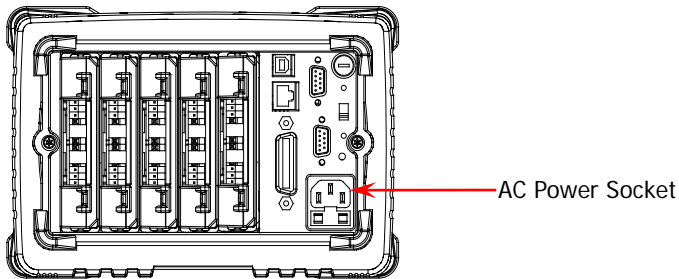

2 Start the instrument

Press the power key at the front panel and the instrument starts.

After the instrument starts, it checks the modules. This process would take several to dozens of seconds according to the number of modules inserted. During this process, user operation is forbidden.

3 Check the instrument following the steps below if the instrument does not start normally





- 1) Check whether the power is correctly connected.
- 2) Check whether the power key at the front panel is really on.
- 3) Check whether the power fuse is burned out. If the fuse needs to be changed, use the specified fuse.
- 4) Check whether the correct power voltage is selected. Please select the proper power voltage according to the power supply voltage.
- 5) Restart the instrument after finishing the above inspections. If it still does not work correctly, please contact **RIGOL**.

User Interface



Figure 1-5 User Interface

1. Status Bar

- Help Displayed when the built-in help is enabled.
- Error Displayed when an error occurs.
-  Displayed when the keyboard is locked.
-  Displayed when an alarm is generated.
-  Displayed when the system sound is disabled.
-  Displayed when the instrument is connected to a network correctly.
-  Displayed when an USB storage device is detected.
- Local Displayed when the instrument is in local mode.
- Rmt Displayed when the instrument is in remote mode.

2. Content Area

Display the measurement configuration guide, measurement parameters settings, etc. For more detailed information, please refer to the User's Guide.

3. Menu Bar

Display the menus of the current function corresponding to the menu softkeys below respectively. Pressing the softkey can activate the corresponding menu.

To Input Filename

M300 supports filenames consisting of Chinese characters, English letters and numbers. The length of the filename cannot exceed 12 bytes. The filename input interface is as shown in the figure below.



Figure 1-6 Filename Input Interface

1 Input Mode Icon/Chinese Character Selecting Area

Display the icon of the input mode currently selected.

- Chinese input mode: display 拼音
- English uppercase input mode: display ABC
- English lowercase input mode: display abc

In addition, in Chinese input mode, this area displays Chinese characters for selection. Use the numeric keyboard to input the number corresponding to the Chinese character to input the desired Chinese character.

2 Filename Input Area



Display the letter entered. You can use the left/right direction key to select the desired letter to edit.

3 Letter Selecting Area

Use the direction keys to select desired letter and press **OK**.

4 Switch the Input Mode

Press **Ch/A/a** to switch the input mode to Chinese, English uppercase or English lowercase.

- Chinese: can input Chinese characters and number (from 0 to 9) and  is displayed in the "Input Mode Icon Area".
- English uppercase: can input English uppercase letters (from A to Z) and number (from 0 to 9) and  is displayed in the "Input Mode Icon Area".
- English lowercase: can input English lowercase letters (from a to z) and number (from 0 to 9) and  is displayed in the "Input Mode Icon Area".

5 Switch the Cursor

Press **Cursor** to switch the cursor to select "Filename Input Area", "Letter Selecting Area" or "Chinese Character Selecting Area" (only available in Chinese input mode).

- When "Filename Input Area" is selected, you can use left/right direction key to select desired letter to edit.
- When "Letter Selecting Area" is selected, use the direction keys to select desired letter and press . At this point, letters in "Filename Input Area" or "Chinese Character Selecting Area" varies.
- In Chinese input mode, when "Chinese Character Selecting Area" is selected, you can use the up/down direction key to open the previous or next page of "Chinese Character Selecting Area" and use the numeric keyboard to input the number corresponding to the Chinese character to input the desired Chinese character.

6 Delete

Press this softkey to delete the letter selected by the cursor in "Filename Input Area".

7 OK

Press this softkey to use the letters displayed in "Filename Input Area" as the filename.

8 Return

Press this softkey to cancel inputting filename and return to the previous menu.

Plug-in Module Overview

The M300 provides 8 kinds of modules. These include a DMM module, 20-channel multiplexer, 32-channel multiplexer, 64-channel multiplexer, multi-function module, etc. This section introduces the functions and characteristics of each module.

Outside View Drawing of the Module

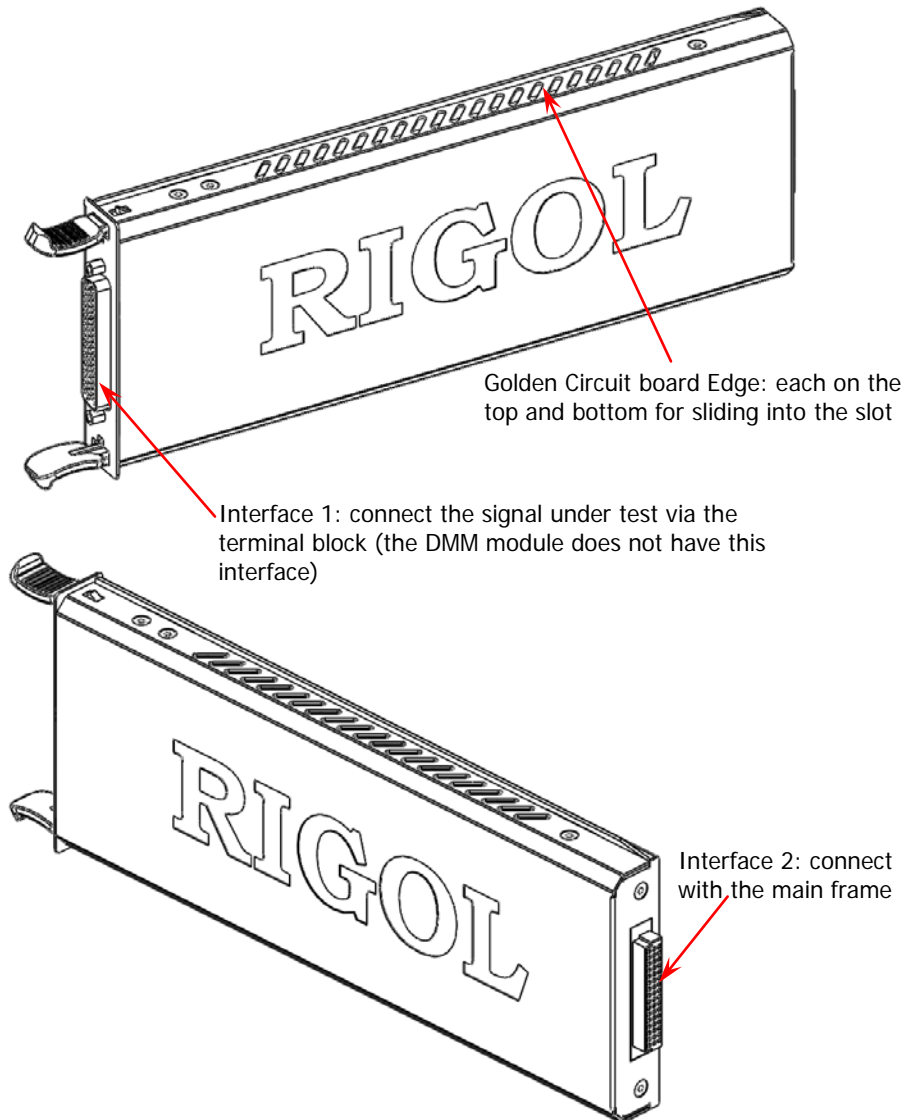

Figure 1-7 Outside view drawing of the module

Insert the Module into the Mainframe

Please turn the mainframe off and insert the modules following the instructions below.

As shown in Figure 1-7, there is a golden circuit board edge both on the top and bottom of the module. Aim the two edges with the sliding chutes (as pointed out by the arrows in the figure below) into the main frame slot and push the module in until you hear a sound. At this point, interface 2 is connected to the main frame.

Note: Please refer to “**Measurement Connections**” to connect the external terminal block and the signals to be measured and then insert it into the mainframe.

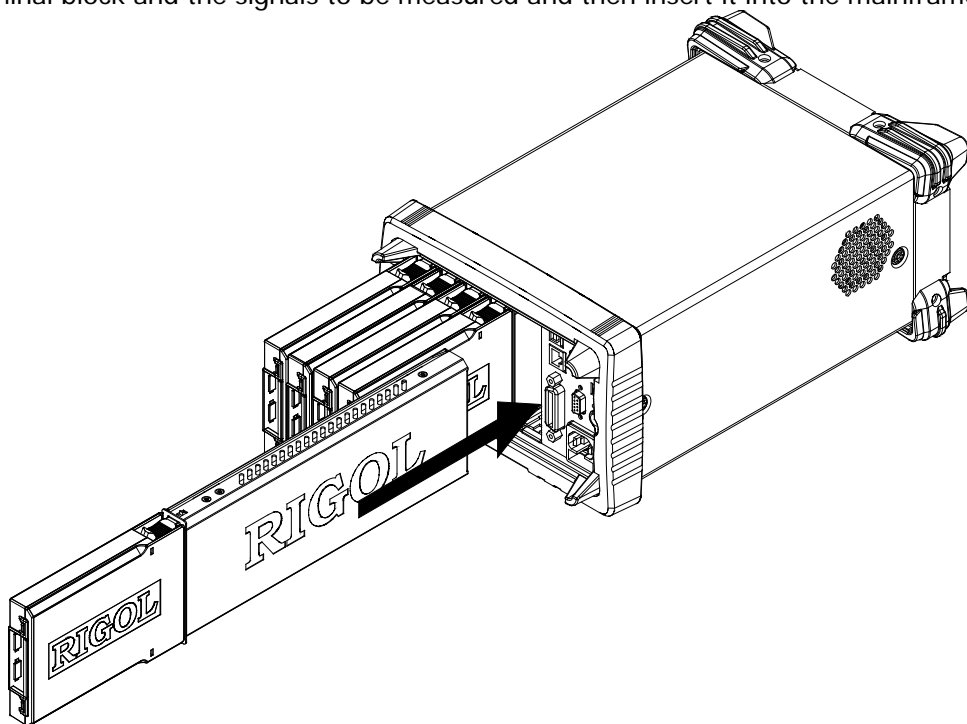

Figure 1-8 Insert the Module into the Mainframe

Note:

All the modules of the M300 do not support hot-plugging. Please turn the mainframe off before inserting the modules into the mainframe.

Module Overview

MC3065 (DMM Module):

The DMM module is used to measure the signals under test and has 6½ digit reading resolution. The measurement functions include DCV, ACV, 2-wire resistance, 4-wire resistance, frequency, period, temperature and any sensor.

After connecting the DMM module, make sure that the signal under test connected to the analog bus is no greater than 300 Vdc or 300 Vrms.

MC3120 (20-Channel Multiplexer):

All 20 channels switch both HI and LO inputs, thus providing fully isolated inputs to the DMM module. MC3120 is divided into two banks (called A and B) of 10 two-wire channels each. When making 4-wire resistance measurement, the instrument automatically pairs channels of A bank and B bank. All channels in the scan list are break-before-make. You can close multiple channels on this module only if you have not configured any channel to be part of the scan list.

This module can be connected with MC3065 (DMM Module, if MC3065 is currently inserted).

MC3132 (32-Channel Multiplexer):

All 32 channels switch both HI and LO inputs, thus providing fully isolated inputs to the DMM module. MC3132 is divided into two banks (called A and B) of 16 two-wire channels each. When making 4-wire resistance measurement, the instrument automatically pairs channels of A bank and B bank. All channels in the scan list are break-before-make. You can close multiple channels on this module only if you have not configured any channel to be part of the scan list.

This module can be connected with MC3065 (DMM Module, if MC3065 is currently inserted).

MC3164 (64-Channel Single-Ended Multiplexer):

All 64 channels can switch the HI input only. MC3164 is divided into two banks (A and B) of 32 single-ended channels each. All channels in the scan list are break-before-make. In any case, you cannot close multiple channels on this module.

This module can be connected with MC3065 (DMM Module, if MC3065 is currently inserted) but cannot be used for 4-wire resistance measurement.

MC3324 (24-Channel Multiplexer):

The MC3324 is a mixed multiplexer with 20 voltage channels and 4 current channels. All 20 voltage channels switch both HI and LO inputs, thus providing fully isolated inputs to the DMM module, and is divided into two banks (called A and B) of 10 two-wire channels each. When making 4-wire resistance measurement, the instrument automatically pairs channels of A bank and B bank. All channels in the scan list are break-before-make. You can close multiple channels on this module only if you have not configured any channel to be part of the scan list.

4 current channels are used in combination with the DMM module to measure DC current or AC current. All channels in the scan list are break-before-make. In any case, you cannot close multiple channels on this module.

This module can be connected with MC3065 (DMM Module, if MC3065 is currently inserted).

MC3416 (16-Channel Actuator):

The MC3416 can connect signals to the device under test or enable external devices. Any of the 16 channels can switch to Normally-Open (NO) and Normally-Closed (NC) states.

MC3534 (Multifunction Module):

This module provides 3 kinds of functions with 4 channels for each function. This module can be used to check status or control external devices (such as solenoid, power relays and microwave switches). You can also read digital inputs and the totalizer count during a scan.

- Four 8-bit digital input/output (DIO) ports
- 4 totalizer (TOT) input terminals (the first two channels are 10 MHz TOT and the other two channels are 100 kHz TOT) with 1 Vpp sensitivity
- 4 analog output terminals, ± 12 V calibrated voltage

MC3648 (4×8 Matrix Switch):

The MC3648 is used to connect multiple devices to multiple points on the device under test. You can connect the rows and columns of multiple matrix switches to form relatively larger matrix (such as 8×8 and 4×16, the number of crosspoints cannot exceed 160).

32 two-wire cross points which can connect any combination of inputs and outputs at the same time.

To Use the Built-in Help System

The built-in help system of M300 provides the help information about any front panel key and menu. To acquire the help information of any front panel key or menu, press **Help** (the backlight goes on and “Help” is displayed in the status bar in the user interface) and then press the desired key. The built-in help interface is as shown in the figure below. Press **OK** to exit.

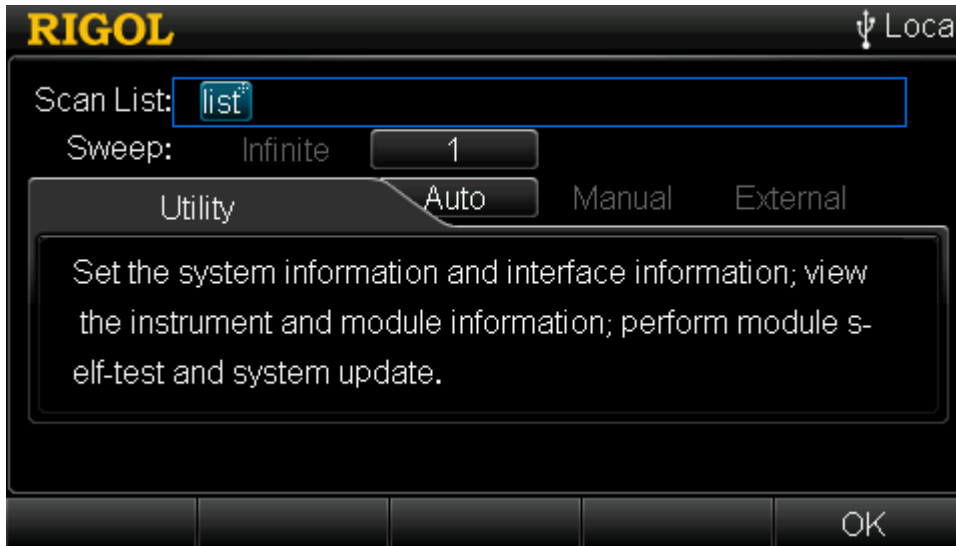

Figure 1-9 Built-in Help System

Measurement Connections

Multiple signals to be measured are connected to the plug-in modules through the external terminal blocks and then switched to the DMM module or external DMM. M300 provides 7 kinds of terminal blocks. The models of the terminal blocks and corresponding modules are listed in the table below. This section introduces how to connect the signals to be measured through the external block.

Table 1-1 External Terminal Blocks

	Terminal Block	Module
1.	M3TB20	MC3120
2.	M3TB32	MC3132
3.	M3TB64	MC3164
4.	M3TB24	MC3324
5.	M3TB48	MC3648
6.	M3TB16	MC3416
7.	M3TB34	MC3534



WARNING

Cut off all the power supplies before opening the terminal block or removing the terminal block from the module.

1. Place the terminal block with the front (with the **RIGOL** caption) facing downward and pull the two latches in the arrow direction in the figure below and press them down. Place the terminal block with the front facing upward and pull the upper cover of the terminal block upward and remove it.

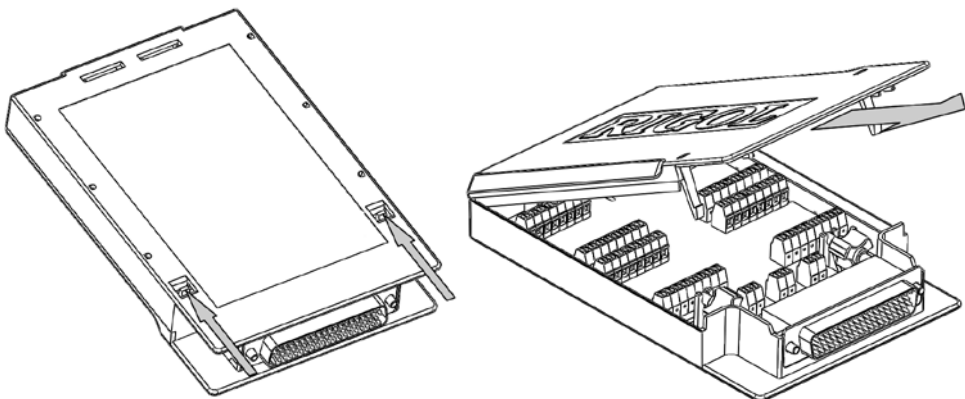

2. Connect the cables for connecting the signal under test according to the labels on the circuit board of the terminal block (for the connecting method, refer to

Table 1-2). Pass the binding wires through the two groups of holes as pointed out by the arrows in the figure below to fix the cable connected. Pay attention to the channel or terminal connected to the cable to ensure that the signal connected is correct.

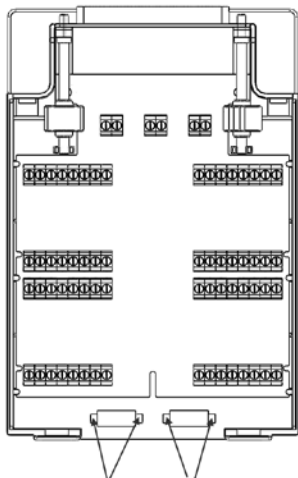

Note:

- For the connection method of each module and the corresponding terminal block as well as the specification requirements of the connecting cable, please log in **RIGOL** official website (www.rigol.com) to get more related materials.
- When using the multiplexer module for measurement, make sure that both the amplitude of the signal under measurement and the common mode voltage are no greater than the maximum input voltage of the module.
- When the multiplexer module is used to measure an object with high-power output ability (such as battery and power supply), to avoid damaging the relay, you are recommended to connect a fuse in serial when making connections (as shown in the figure below).

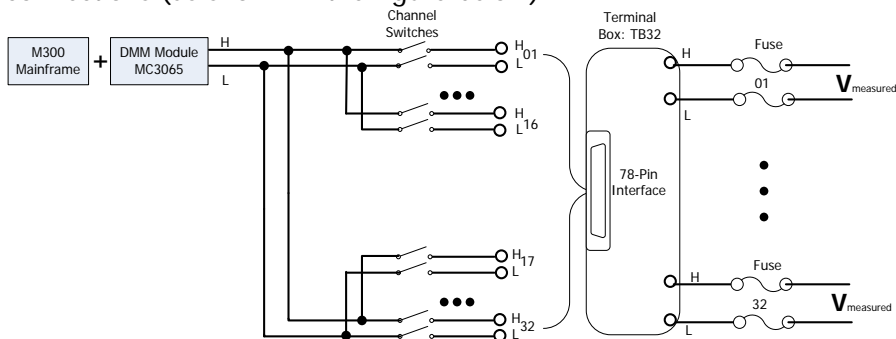
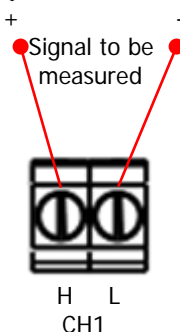
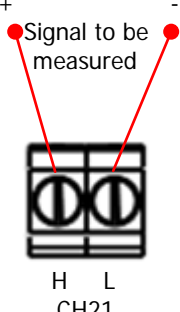
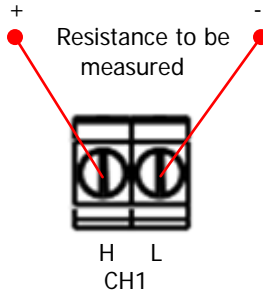
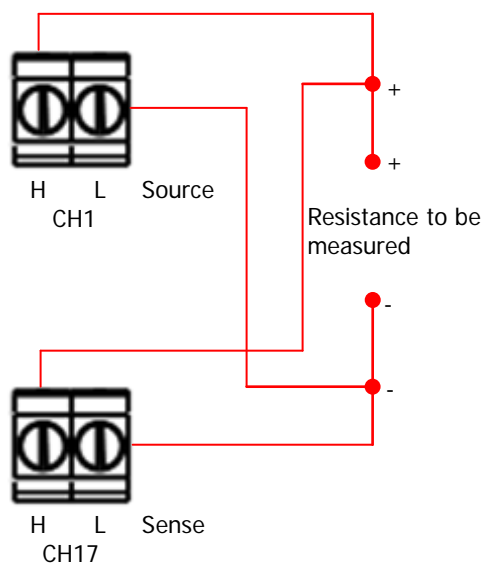
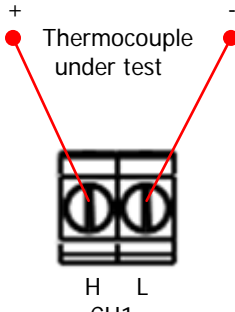

Table 1-2 Measurement Connections

<p>DCV/ACV/FREQ/PERIOD/Sensor (DCV, FREQ)</p>  <p style="text-align: center;">H L CH1</p>	<p>DCI/ACI/ Sensor (DCI)</p>  <p style="text-align: center;">H L CH21</p> <p>Note: Only available for the channel 21 to channel 24 of MC3324.</p>
<p>2WR/RTD/Thermistor/ Sensor (2WR)</p>  <p style="text-align: center;">H L CH1</p>	<p>4WR/RTD 4W/ Sensor (4WR)</p>  <p style="text-align: center;">H L Source CH1</p> <p style="text-align: center;">H L Sense CH17</p> <p>Note: Only available for all the channels of MC3120 and MC3132 as well as the channel 1 to channel 20 of MC3324.</p>
<p>Thermocouple</p>  <p style="text-align: center;">H L CH1</p>	



WARNING

To avoid electric shock, the connecting wire should meet the maximum current requirement. To avoid damaging the module, make sure that all the input signals are within the rated input range.

3. Connect the terminal block to the module via interface 1 (the interface definition is in Figure 1-7) on the module and screw down the two screw rods onto the nuts on the module.

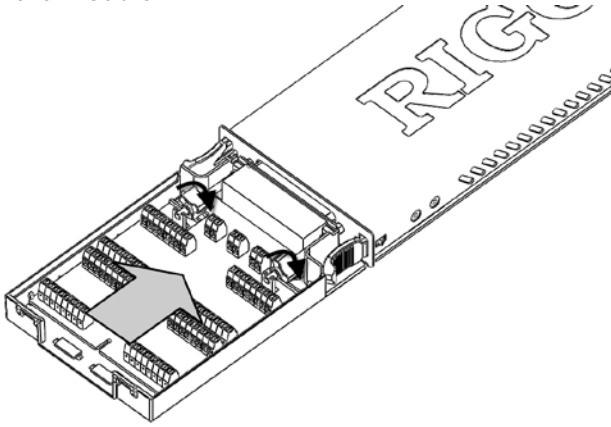

4. Close the upper cover of the terminal block.

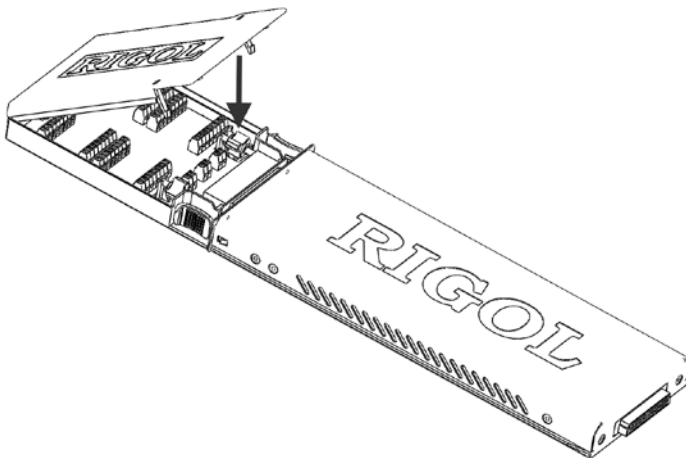

5. Insert the module with the terminal block into the slot of the mainframe.

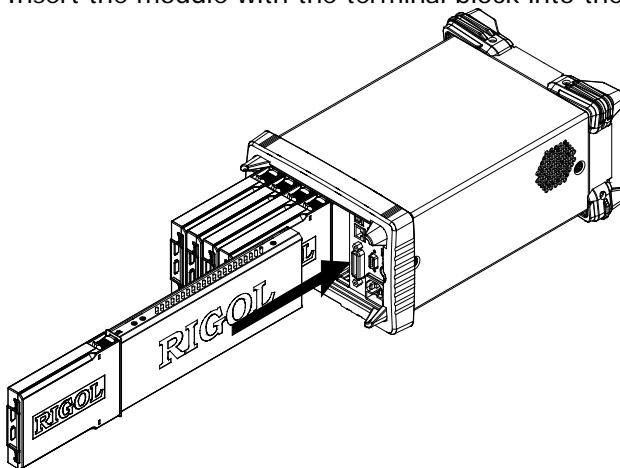

To Replace the Fuse

If a new fuse is required, please refer to the following steps.

- 1 Turn off the instrument and remove the power cord.
- 2 Insert the small straight screw driver into the slot at the power socket and pry out the fuse seat.

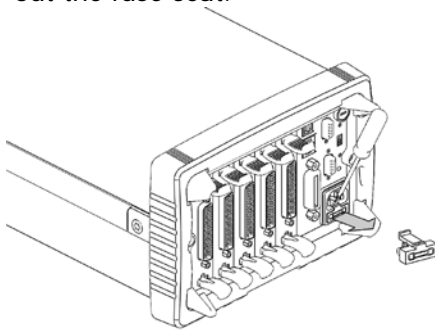

- 3 Replace a specified fuse.

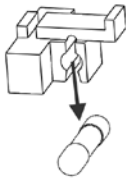

- 4 Insert the fuse seat into the slot.

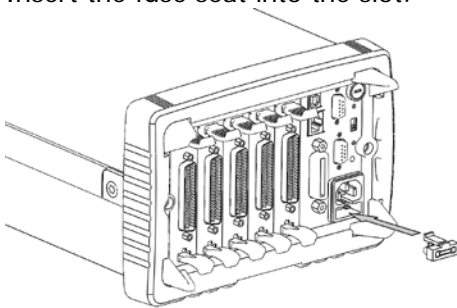

CAUTION

Please use the specified power fuse and make sure that the fuse seat is not short-circuited to avoid electric shock and fire.

Menu Quick Navigation

This section provides the structures of the main menus for M300 to guide users to quickly get familiar with the operations. For more detailed information, please refer to “Front Panel Operations”.

Config

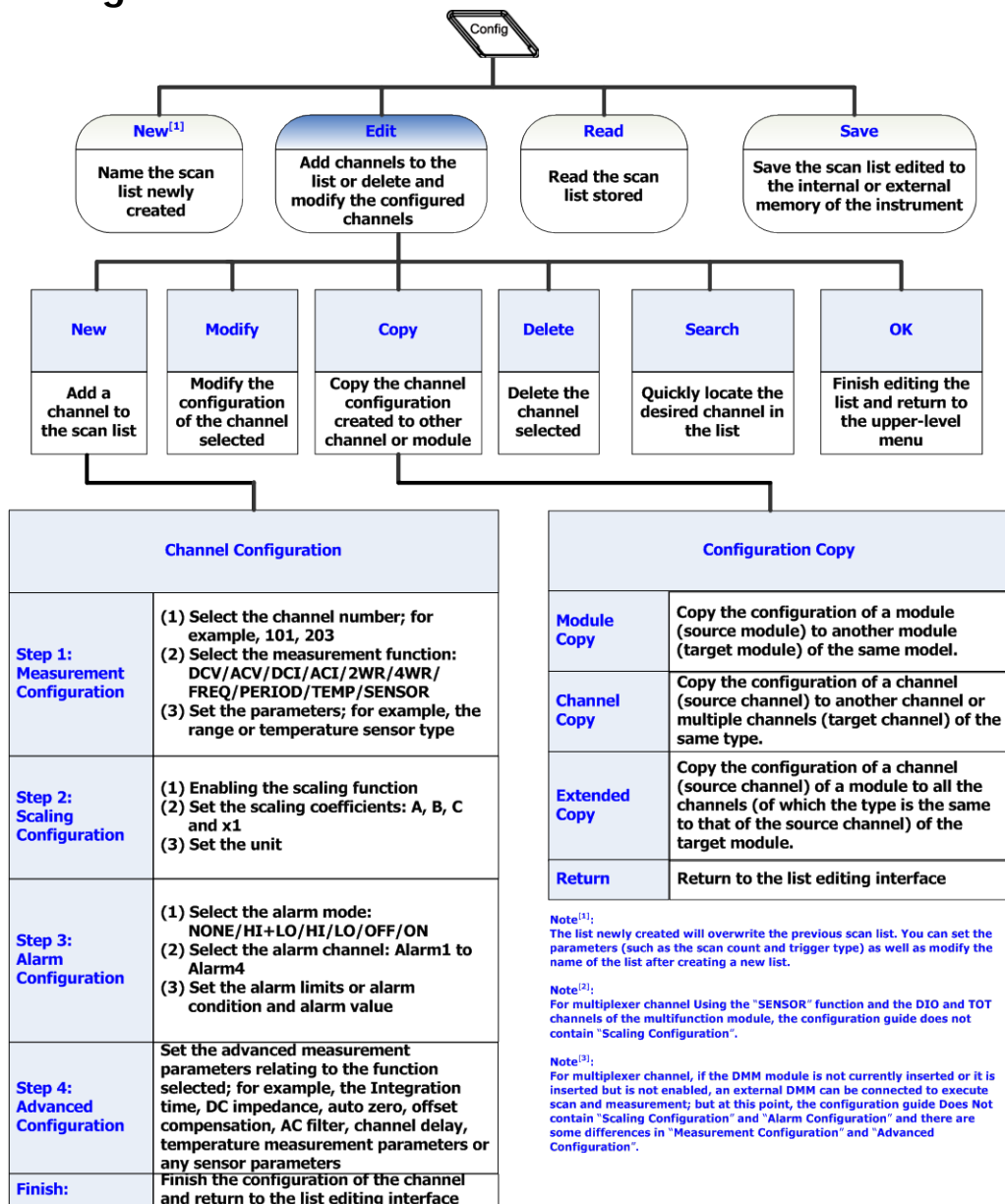

Monitor

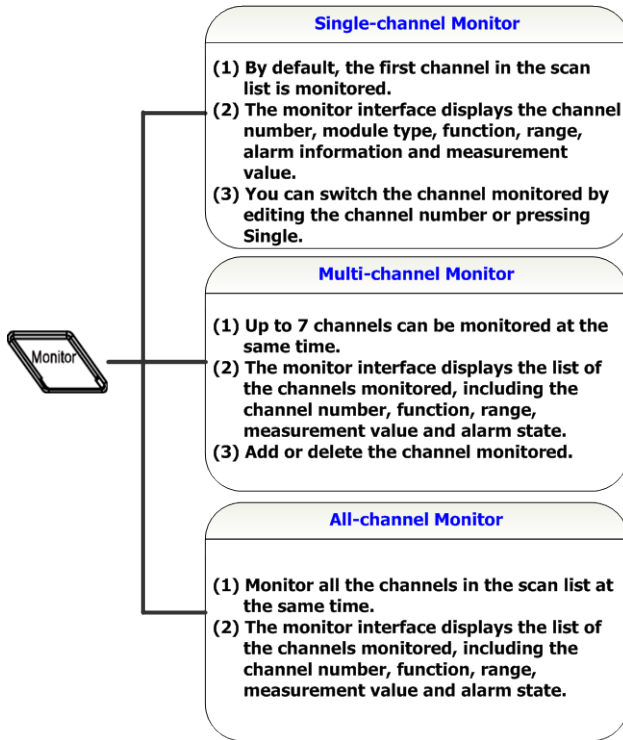

View Switch Key

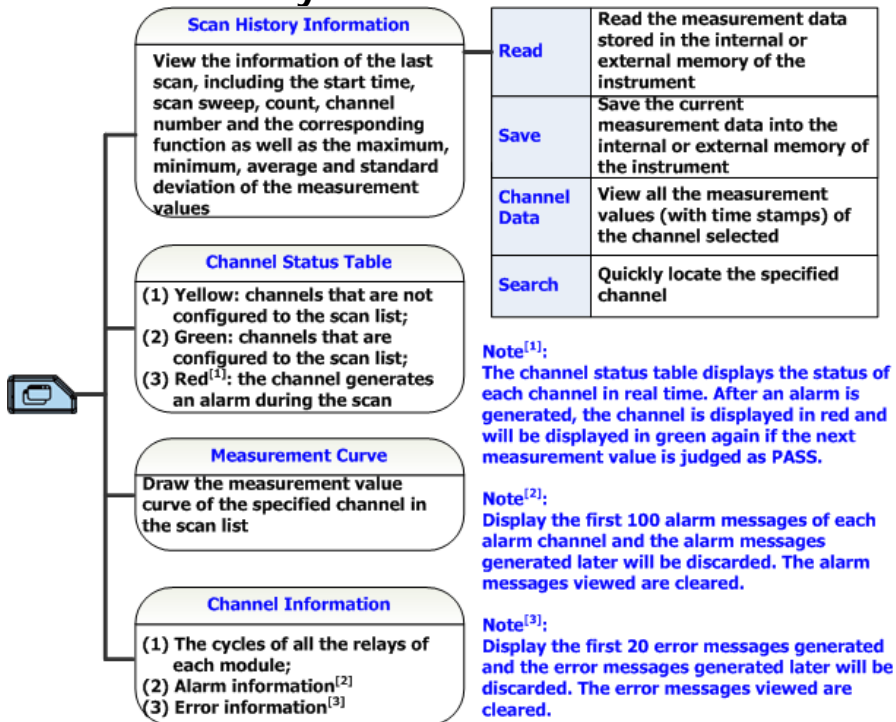

Control

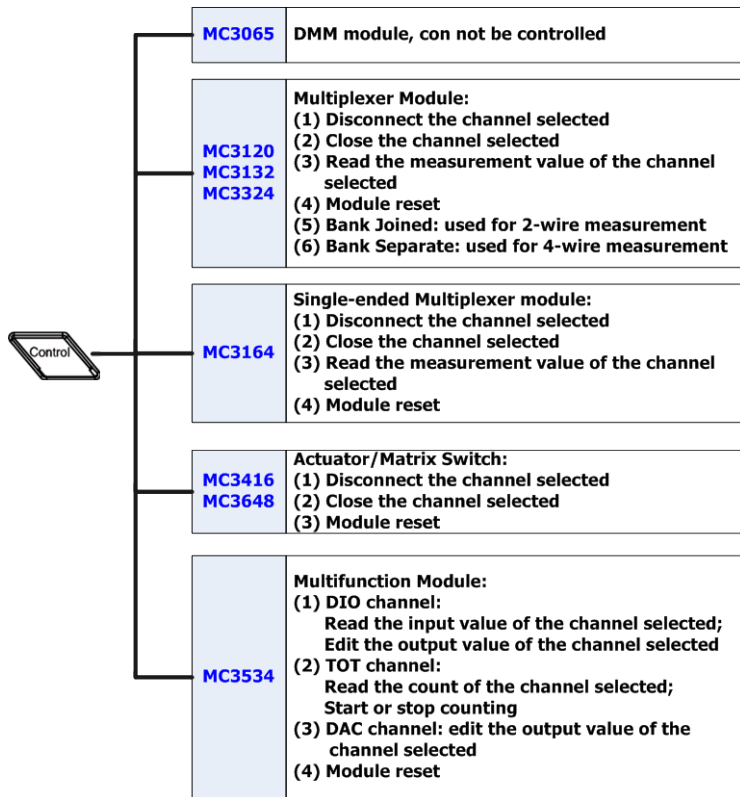

Alarm Channel Setting Keys

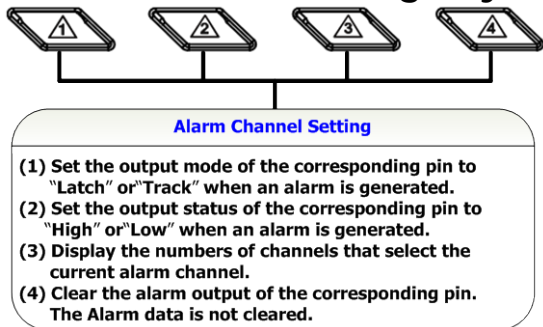

Chapter 2 Front Panel Operations

This chapter introduces in details the front panel operation methods and functions of M300.

Topics in this chapter:

- Scan Configuration
- Channel Monitor
- Module Control
- Alarm Channel Setting
- View Switch
- Store and Recall
- Utility

Scan Configuration

Press **Config** at the front panel to configure M300 to create a scan (create and edit the scan list and configure the parameters of each channel). During the scan, each time the DMM module is connected to one channel in the scan list and executes a measurement according to the channel configuration.

Scan List

Create a scan list, add any channels of the multiplexer or the DIO or TOT channels of the multifunction module to the scan list and configure the basic measurement, scaling, alarm and advanced measurement parameters for each channel. The edited scan list can be stored in internal or external memory and be recalled when required.

To Create a New List

The instrument enters the scan list configuration interface when you start the M300 or press **Config**. You can set the scan parameters (such as sweep count, trigger mode) as well as create, edit, recall and save the scan list.

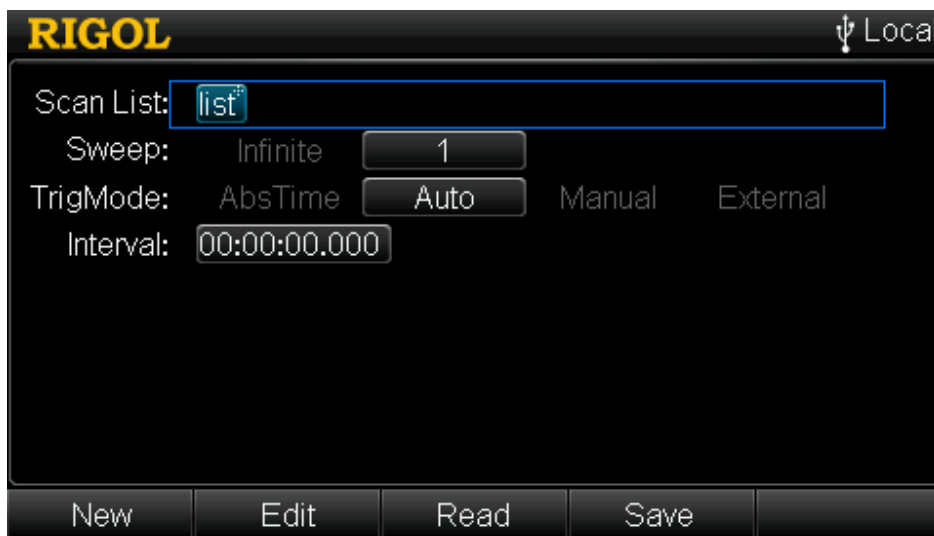

Figure 2-1 Scan List Configuration Interface

1 To Create Scan List

Press **New** to create a new scan list and enter the filename input interface. At this point, you can input the desired list name by referring to **“To Input Filename”** and press **OK**. The scan list name can consist of Chinese characters, English uppercase/lowercase letters and numbers and cannot exceed 12 bytes

(each English letter or number occupies 1 byte and each Chinese character occupies 2 bytes).

To modify the name of the scan list created, please select **Scan List** firstly and press **OK** to enter the filename input interface.

2 Sweep Count

Select **Sweep** using the up/down direction key and select "Infinite" or "1" (you need to set a value) using the left/right direction key.

- Infinite: execute continuous scan. You can press and hold **Run/Stop** to stop the scan.
- Number of Scans: you can use the numeric keyboard to set a value. The range is from 1 to 50000. After executing the specified number of scans, the instrument stops scanning automatically.

3 Trigger Mode

Select **TriggerMode** using the up/down direction key and select "Auto", "Manual", "External", "AbsTime" or "Alarm" using the left/right direction key.

- Auto: the instrument executes infinite scan or the specified number of scans at the specified interval automatically.
- Manual: the instrument executes a scan when you press **Run/Stop**.
- External: the instrument executes a scan when the external trigger signal input interface receives a TTL trigger pulse.
- AbsTime: the instrument executes a scan when the system time reaches the specified time.
- Alarm: the instrument executes a scan when an alarm is generated from the specified alarm channel.

For details of the trigger mode, refer to "**Trigger Mode**".

4 Interval

Interval is defined as the time interval between the start of a scan to the start of the next scan in auto scan mode as shown in the figure below. When the trigger mode is "Auto", select **Interval** using the up/down direction key and use the numeric keyboard to set a desired interval. The range is from 00:00:00.000 to 99:59:59.999 (the time format is Hour:Minute:Second.Millisecond) and the default is 00:00:00.000.

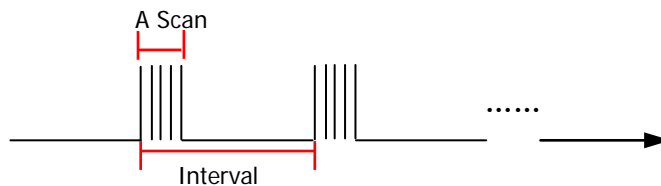

5 Advanced Source (Available only when the DMM module is not installed or disabled)

This setting is only available when an external digital multimeter is used. The advanced source provides the advanced channel signal. When receiving the advanced channel signal, the instrument disconnects the channel currently selected and closes the next channel in the scan list.

When an external DMM is connected, use the up/down direction key to select **Adv Src** and use the left/right direction key to select the desired advanced source.

- Auto:
After finishing measuring the current channel, the current channel is disconnected and the next channel in the list is closed automatically.
- Single:
After finished measuring the current channel, the unit will wait for user input before moving to the next channel in the list. Pressing **Single** to disconnect the current channel and close the next channel.

Because both the "Single" advanced source and the manual trigger use the same way, pressing **Single**, to generate signal, the manual trigger mode does not support "Single" advanced source.

- External:
The scan will advance after receiving a trigger on the external advanced channel signal. This signal, typically the VMC signal from the external DMM, is input from pin 6 of the Alarm/Ext Trig interface (converted from the **[RS-232/Alarms/Ext Trig]** interface). After "External" is selected, you need to select the edge type of the input signal (use the up/down direction key to select **Input Edge** and use the left/right direction key to select "Rising" or "Falling").

As the "External" advanced source input and the external trigger input use the same pin, the external trigger mode does not support "External" advanced source.

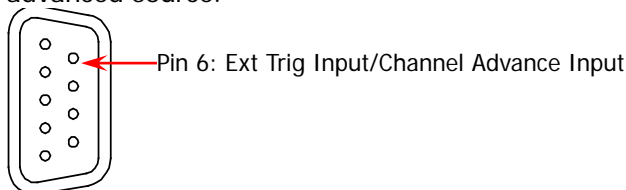

Alarms/Ext Trig Interface

6 Absolute Time

Absolute time is defined as the time when the instrument executes the scan in

absolute time scan mode. When the trigger mode is "AbsTime", select **AbsTime** using the up/down direction key and set the desired time using the numeric keyboard. The time format is "Month-Date Hour:Minute:Second". You need to set a valid time. The ranges of the parameters are as follows.

Month: 01 to 12

Date: 01 to 31, 30, 29 or 28

Hour: 00 to 23

Minute: 00 to 59

Second: 00 to 59

The instrument can also ignore some time parameters and trigger when the system time fulfills some of the parameters. Use "." on the numeric keyboard to set the parameters to be ignored and the corresponding position will display "***". For example, set the instrument to ignore the "Month" and "Date" and trigger at 8:00 every day; use the numeric keyboard to set the absolute time to "***.** 08:00:00".

7 Alarm Channel

When the trigger mode is set to "Alarm", select **Channel** using the up/down direction key and set the alarm channel to "Alarm1", "Alarm2", "Alarm3" or "Alarm4" using the left/right direction key. The instrument executes a scan when an alarm is generated from the channel selected.

8 Trigger Edge Type

When the trigger mode is "External", select **Edge** using the up/down direction key and select "Rising" or "Falling" using the left/right direction key. The instrument executes a scan when a TTL trigger pulse with specified edge is received by the external trigger signal input terminal.

To Edit the List

Press **Config** → **Edit** to enter the scan list editing interface.



Figure 2-2 Scan List Editing Interface

- 1 New**
Create a new channel configuration. Press this softkey to enter the channel configuration guide. Finish all the configurations according to the introductions in “**Channel Configuration**” and press **Done** to return to the scan list editing interface.
- 2 Copy**
Copy the channel configuration created to other channel or module. For details, refer to the introduction in “**Configuration Copy**”.
- 3 Modify**
Modify the channel configuration created. Select the desired channel using the direction keys and press **Modify** to open the configuration guide of the corresponding channel. At this point, you can modify the configuration of this channel and after the modification is finished, press **Done** to return to the scan list editing interface.

Note: The channel in **Chan No.** can only be modified to the channels in the scan list.
- 4 Delete**
Delete a channel configuration created. Select the channel to be deleted using the direction keys and press **Delete** to delete the corresponding channel.

5 Search

When a great number of channels are added into the scan list, you can press **Page Dn** → **Search**, use the numeric keyboard to input the desired channel number and then press **OK** to quickly locate this channel. You can copy, modify or delete the channel configuration located.

To Save the List

The M300 allows users to save the configured scan list in internal or external memory as measurement configuration file.

Press **Config** → **Save** to enter the store and recall interface (the file type is automatically set to "Measurement configuration"). Select the desired directory according to the method introduced in "**Store and Recall**" and then press **Save** to enter the filename input interface. Input the specified filename to save the current scan list.

You can read the scan list stored as well as modify its configuration and save it again.

To Read the List

The M300 allows users to read the scan list stored. Press **Config** → **Read** to enter the store and recall interface (the file type is set to "Measurement Configuration" automatically). Select and read the desired file according to the method introduced in "**Store and Recall**".

You can modify the configuration of the scan list read and save it again.

Trigger Mode

The M300 provides 5 trigger modes including auto trigger, manual trigger, external trigger, absolute time trigger and alarm trigger.

Auto Trigger

In auto trigger mode, the scan rate is determined by the specified interval. If the time required for a complete scan of the scan list is greater than the specified interval, the instrument will execute a continuous scan at the fastest possible rate (no error message will be generated).

The range of the interval is from 0 ms to 99:59:59.999 hours (the time format is "Hour:Minute:Second.Millisecond") and the resolution is 1 ms.

If the number of scans is set to "Infinite", press **Run/Stop** at the front panel and the instrument executes a continuous scan automatically at the specified interval. You can press and hold the key to stop the scan.

If the number of scans is a specific value (1 to 50000), press **Run/Stop** at the front panel and the instrument executes the specified number of scans at the specified interval and then stops automatically.

During the scan, the instrument stores the measurement data, scaling data and alarm data in the non-volatile memory automatically. You can press  at the front panel to view the history measurement data (including the maximum, minimum, average and standard deviation).

Manual Trigger

In manual trigger mode, after you press **Run/Stop** at the front panel, the instrument executes a scan and then enters the wait-for-trigger state. After that, the instrument triggers each time you press **Run/Stop** at the front panel.

If the number of scans is set to "Infinite", after each trigger is finished, the instrument will always stay in wait-for-trigger state. You can press and hold the key to stop the scan and the instrument will exit the wait-for-trigger state.

If the number of scans is set to a specific value (1 to 50000), after the trigger is finished, the instrument enters the wait-for-trigger state. The instrument will exit the wait-for-trigger state when the number of triggers reaches the preset value.

During the scan, the instrument stores the measurement data, scaling data and

alarm data in the non-volatile memory automatically. You can press  at the front panel to view the history measurement data (including the maximum, minimum, average and standard deviation).

External Trigger

To use the external trigger mode, first use the mixed-interface separator line (accessory) to convert the **[RS-232/Alarms/Ext Trig]** interface at the rear panel to two 9-pin interfaces. Wherein, the 9-pin male interface is a standard RS232 interface and the 9-pin female interface is used for alarm output, external trigger signal input (pin 6, as shown in the figure below) and so on. Secondly, you need to select the edge type (rising or falling) for the external trigger signal. In external trigger mode, the instrument initialize a trigger when a trigger signal met the conditions is received by the Ext Trig Input terminal.

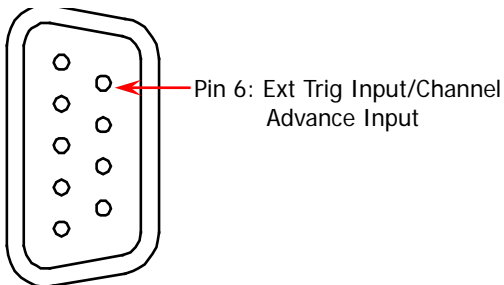

Alarms/Ext Trig

In external trigger mode, if the number of scans is set to "Infinite", after you press **Run/Stop** at the front panel, the instrument enters the wait-for-trigger state and then executes a scan each time an external trigger signal is received. Press and hold **Run/Stop** and the instrument will exit the wait-for-trigger state.

If the number of scans is a specific value, after you press **Run/Stop** at the front panel, the instrument enters the wait-for-trigger state and then the instrument executes a scan each time an external trigger signal is received. After executing the specified number of external triggers, the instrument exits the wait-for-trigger state.

During the scan, the instrument stores the measurement data, scaling data and alarm data in the non-volatile memory automatically.

Absolute Time Trigger

To use the absolute time trigger mode, set an accurate system time for the instrument by referring to “**Date**” and “**Time**”. Then select absolute time trigger mode and set a time. The instrument executes a scan when the system time reaches the specified time. If the system time reaches the next specified time point when the instrument is in a scan, the instrument will ignore the new trigger and continue with the current scan.

The absolute time format is “Month-Date Hour:Minute:Second”. You need to set a valid time. The ranges of the parameters are as follows.

Month: 01 to 12

Date: 01 to 31, 30, 29 or 28

Hour: 00 to 23

Minute: 00 to 59

Second: 00 to 59

The instrument can also ignore some time parameters and trigger when the system time fulfills some of the parameters. Use “.” on the numeric keyboard to set the parameters to be ignored and the corresponding position will display “***”. For example, to set the instrument to ignore the “Month” and “Date” and trigger at 8:00 every day, use the numeric keyboard to set the absolute time to “***-*** 08:00:00”. When parameters in “Month-Date Hour:Minute:Second” are all ignored, it is similar to auto trigger mode.

In absolute time trigger mode, if the number of scans is set to “Infinite”, after you press **Run/Stop** at the front panel, the instrument enters the wait-for-trigger state and then executes a scan each time the system time reaches the specified time. Press and hold **Run/Stop** and the instrument will exit the wait-for-trigger state.

If the number of scans is a specific value, after you press **Run/Stop** at the front panel, the instrument enters the wait-for-trigger state and then executes a scan each time the system time reaches the specified time. After executing the specified number of absolute time triggers, the instrument exits the wait-for-trigger state.

During the scan, the instrument stores the measurement data, scaling data and alarm data in the non-volatile memory automatically.

Alarm Trigger

To use the alarm trigger mode, configure the alarm by referring to “**Alarm Configuration**” and select alarm trigger mode, then select an alarm channel. The instrument executes a scan when an alarm is generated in the specified alarm channel.

In alarm trigger mode, if the number of scans is set to “Infinite”, after you press **Run/Stop** at the front panel, the instrument enters the wait-for-trigger state. Then the instrument executes a scan when an alarm is generated in the specified alarm channel. Press and hold **Run/Stop** and the instrument will exit the wait-for-trigger state.

If the number of scans is a specific value, after you press **Run/Stop** at the front panel, the instrument enters the wait-for-trigger state. Then the instrument executes a scan when an alarm is generated in the specified alarm channel. After executing the specified number of alarm triggers, the instrument exits the wait-for-trigger state.

During the scan, the instrument stores the measurement data, scaling data and alarm data in the non-volatile memory automatically.

Explanation:

The instrument triggers a scan when the trigger condition is met and scans the channels in the scan list in ascending order (from slot 1 to slot 5) automatically. Operations on any channels of the module of which the channel is in the scan list are forbidden. You can press and hold **Run/Stop** at the front panel to stop the scan but after the scan has stopped, it cannot be resumed. When a new scan is executed, all the readings in the memory will be cleared.

Channel Configuration

After creating a new scan list and configuring proper parameters (such as the scan sweep and trigger mode), you need to add channels into the scan list and configure the measurement, scaling, alarm and advanced parameters of the channels. The M300 provides special channel configuration guide for you to easily finish the channel configuration.

The flow diagram of the channel configuration guide is as shown in the figure below.

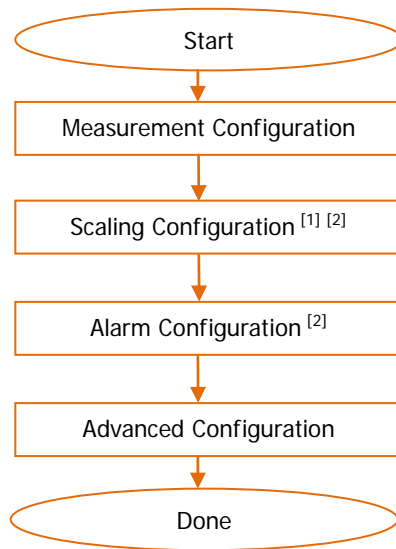

Figure 2-3 Flow Diagram of Configuration Guide

Note^[1]: For multiplexer channels using the “SENSOR” function or the DIO channels and TOT channels of the multifunction module, the configuration guide does not contain “Scaling Configuration”.

Note^[2]: For the multiplexer channels, if the DMM module is not inserted or it is inserted but is not enabled, you can connect an external DMM for scan and measurement. At this point, the configuration guide does not contain “Scaling Configuration” and “Alarm Configuration” and there are some differences in “Measurement Configuration” and “Advanced Configuration”.

Press **Config** → **Edit** → **New** to enter the channel configuration guide. After finishing all the configurations, press **Done**.

Measurement Configuration

The first step in the channel configuration guide: select the channel number, select the measurement function of the specified channel and configure the basic measurement parameters of the selected function.

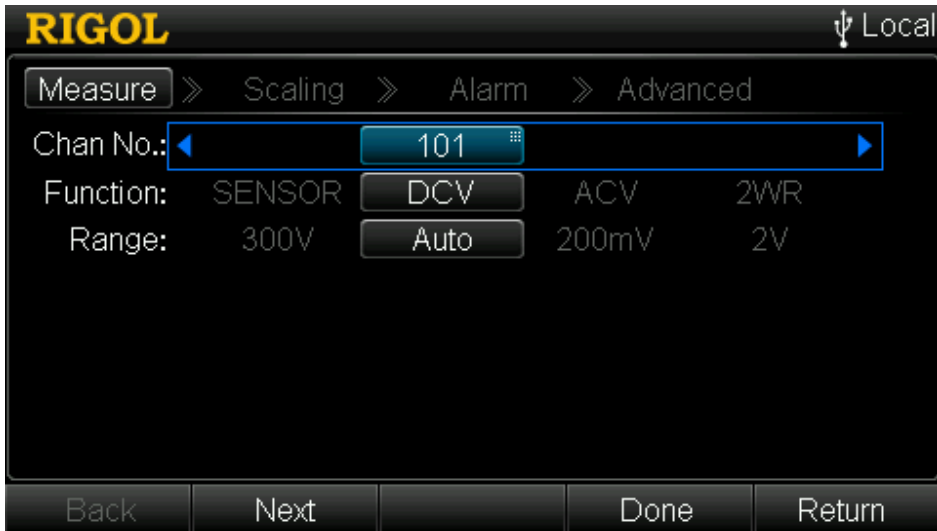
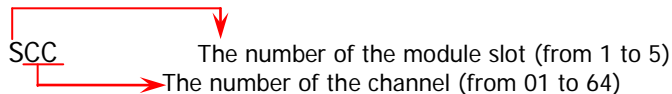

Figure 2-4 Measurement Configuration

1 Channel Number

Select the desired channel number. Generally, the channel number is a 3-digit number where the first digit (from the left) denotes **the number of the module slot** and the other two digits denote **the number of the channel**.



The channels available include all the channels of the multiplexer (S01 to S32/S64/S24), the DIO (S01 to S04) and TOT (S05 to S08) channels of the multifunction module.

After entering the channel configuration guide, **Chan No.** is selected by default. At this point, you can use the left/right direction key to modify the channel number or the numeric keyboard to input the channel number.

Explanation:

If you want to configure the channel of the multiplexer (MC3132 and MC3164), add it to the scan list and use it for measurement, you need to first insert and enable the DMM module (**Utility** → **DMM** → "ON") or connect an external digital multimeter.

2 Function

Use the up/down direction key to select **Function** and the left/right direction key to select the desired measurement function.

If the current channel is the voltage channel of the multiplexer, the measurement functions available include DCV, ACV, 2WR, 4WR (only supported by the first 16 channels of MC3132 and the first 10 channels of MC3120 and MC3324), FREQ, PERIOD, TEMP and SENSOR. If the channel is current channel (only for MC3324), the measurement functions available include DCI, ACV and SENSOR. After selecting the desired measurement function, please configure the basic measurement parameters for the function selected by referring to "**Measurement Parameter Configuration**" and press **Next** to configure the scaling or alarm parameters.

If the current channel is the DIO channel of the multifunction module, **Function** is fixed at "DIO". Please refer to "**Digital Input**" to set the basic parameters and press **Next** to configure the alarm parameters.

If the current channel is the TOT channel of the multifunction module, **Function** is fixed at "TOT". Please refer to "**Totalizer**" to set the basic parameters and press **Next** to configure the alarm parameters.

Scaling Configuration

The second step of the channel configuration guide: configure the scaling parameters.

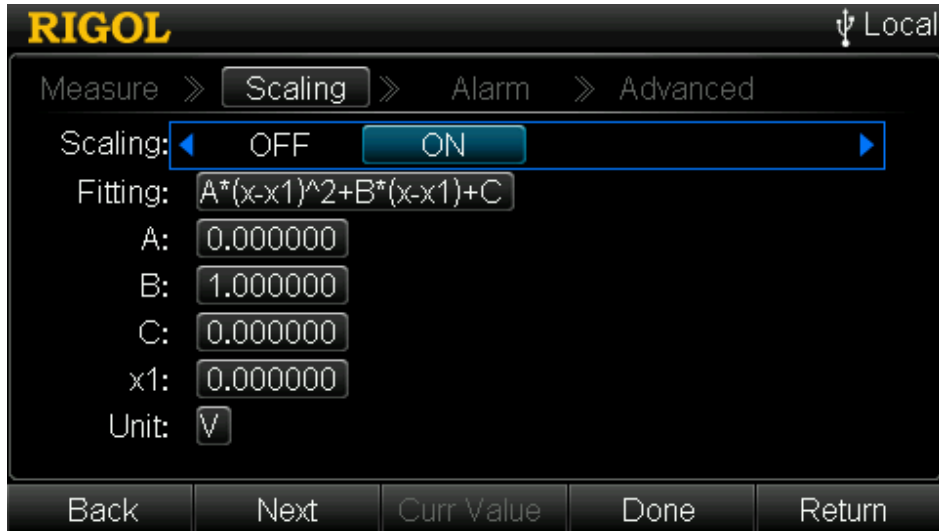

Figure 2-5 Scaling Configuration

Note: For multiplexer channels that are using the “SENSOR” function and the DIO and TOT channels of the multifunction module, the configuration guide does not contain scaling configuration. Also note that the multiplexer channels that are not using the DMM module, the configuration guide also does not contain “Scaling Configuration”.

The M300 provides a scaling function. This function has three scaling coefficients (A, B and C) for all the readings of the channel selected. The formula for the scaling function is as follows.

$$\text{Scaling Reading} = A \times (x - x1)^2 + B \times (x - x1) + C$$

Wherein, x is the reading measured. x1 is the correction value (can be a reading measured at certain time or a value defined by user). Subtracting x1 from all readings can correct the zero point of the fitting curve.

You can configure the scaling function for all the multiplexer channels (except channels using the “SENSOR” function or when external DMM is connected). Before applying the scaling function, you must configure the measurement parameters of the channel. After applying the scaling function, if the measurement function is modified, the scaling function will be disabled and the scaling coefficients will be reset.

If the channel using the scaling function is removed from the scan list, the scaling function of the channel will be disabled but the scaling coefficients will not be reset. When the channel is added into the scan list again (without changing the measurement function), the scaling function will be enabled and the scaling coefficients remain unchanged.

For a channel using the scaling function, when it is in single-channel monitor, all the measurement readings are scaling readings.

1 Enable Scaling Configuration

Enter the scaling configuration interface and **Scaling** is selected by default. You can use the left/right direction key to select "ON". At this point, the fitting function, coefficients and unit are displayed on the interface.

2 Set the Fitting Function Coefficients

Use the up/down direction key to select **A**, **B** and **C** respectively and use the numeric keyboard to input the desired values. The range is from $-1E+15$ to $1E+15$ and the default is 0. The fitting function defined is displayed in **Fitting**.

3 Set x1

Use the up/down direction key to select **x1** and press **Curr Value** to acquire the current reading as x1. You also can set x1 by using numeric keyboard.

4 Set the Unit

Set the unit of the measurement result. Use the up/down direction key to select **Unit** and then press **OK** to enter the filename input interface. Input the desired unit and press **OK**. The length of user-defined units cannot exceed 3 bytes. You can use direction keys to select C, F and O respectively and then press and hold the **OK** key to enter °C, °F and °.

Coefficient Setting Explanation:

When setting the fitting function coefficients (A, B and C), press any key on the numeric keyboard to open the dialog box in the form below.

- **Sign:** use the left direction key to move the cursor to the sign bit and press **+/-** on the numeric keyboard to switch the sign to "+" or "-".
- **Unit:** use the right direction key to move the cursor to the unit bit and use the up/down direction key to select the desired unit. The units available include n (10^{-9}), u (10^{-6}), m (10^{-3}), _ (1), K (10^3), M (10^6), G (10^9), T (10^{12}) and P (10^{15}).
- **Number:** use the left/right direction key to move the cursor to the number bit and use the numeric keyboard to input the desired value.

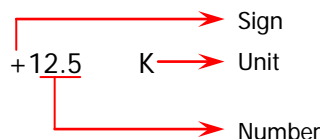

Alarm Configuration

The third step of channel configuration guide: configure the alarm parameters.

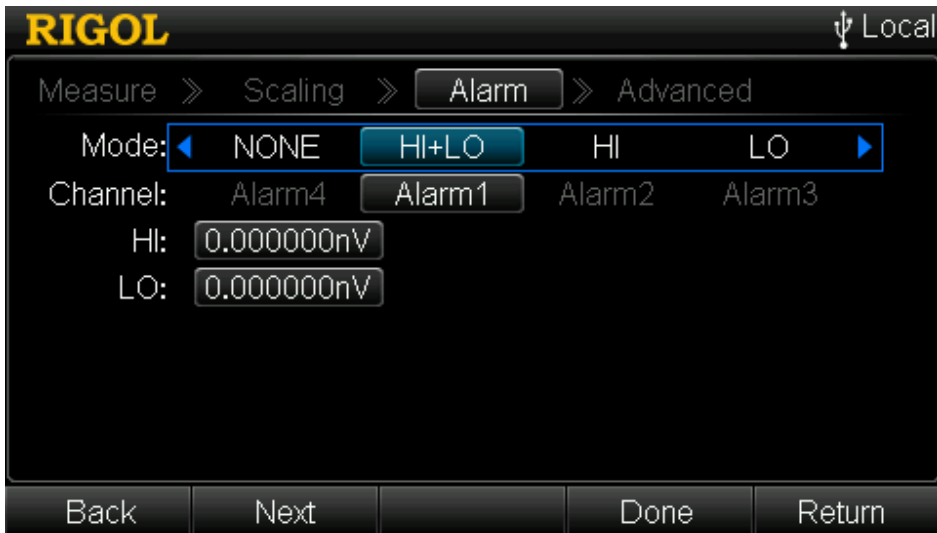

Figure 2-6 Alarm Configuration

Note: For multiplexer channel, if the DMM module is not currently inserted or it is inserted but is not enabled, the configuration guide does not contain “Alarm Configuration” when you connect an external DMM to execute scan and measurement.

M300 has 4 alarm channels (Alarm1, Alarm2, Alarm3 and Alarm4; refer to “**Alarm Channel Setting**”). You can configure an alarm channel and set the alarm limits (high limit, low limit or both limits) for channel in the scan list. During the scan, an alarm will be generated in the alarm channel when readings that exceed the specified limit are detected.

If an alarm is generated during the scan, the alarm data is stored in the reading memory as well as the alarm queue which is separate from the reading memory. The non-scanned alarms (alarms during single-channel monitor, alarms generated by the DIO channel, etc.) can only be stored in the alarm queue.

You can assign multiple channels to any of the 4 alarm channels and use the same alarm limit on multiple channels, but you cannot assign multiple alarm channels and alarm limits to the specified channel.

You can configure the alarm parameters for the DIO and TOT channels that are not added into the scan list.

1 Select the Alarm Mode

Enter the alarm configuration interface, **Mode** is selected by default and you can use the left/right direction key to select the desired mode. If the DIO channel is currently used, the options available are "OFF" and "ON". If the TOT channel is currently used, the options available are only "NONE" and "HI".

- NONE: disable the alarm configuration.
- HI+LO: when the measurement value is greater than HI or lower than LO, an alarm will be generated from the corresponding alarm channel.
- HI: when the measurement value or the count of the TOT channel is greater than HI, an alarm will be generated from the corresponding alarm channel.
- LO: when the measurement value is lower than LO, an alarm will be generated from the corresponding alarm channel.
- OFF: disable the alarm parameters (only for DIO channel).
- ON: enable the alarm configuration. Note that you need to select the alarm channel, set the alarm condition, and alarm value (only for DIO channel).

2 Select the Alarm Channel

Use the up/down direction key to select **Channel** and use the left/right direction key to select the desired alarm channel.

- Alarm1: select Alarm1 as the alarm channel of the current channel.
- Alarm2: select Alarm2 as the alarm channel of the current channel.
- Alarm3: select Alarm3 as the alarm channel of the current channel.
- Alarm4: select Alarm4 as the alarm channel of the current channel.

3 Set the Alarm Limits (only for multiplexer channel and TOT channel)

After setting the alarm mode to "HI", "LO" or "HI+LO", you can use the up/down direction key to select **HI** and/or **LO** to set the alarm limits.

- HI: use the numeric keyboard to input the desired value and press **OK**. For TOT channel, the range of HI is from 0 to $2^{32}-1$ (4294967295).
- LO: use the numeric keyboard to input the desired value and press **OK**.

Note: If the current alarm mode is "HI+LO", the value of HI must not be lower than the current value of LO.

4 Set the Alarm Condition (only for DIO channel)

Use the up/down direction key to select **Condition** and use the left/right direction key to select the desired alarm condition.

- Not Pattern: generate an alarm when the reading of the current channel does not match the alarm value set.
- Pattern: generate an alarm when the reading of the current channel matches the alarm value set.

5 Set the Alarm Value (only for DIO channel)

Use the up/down direction key to select **Value** and use the numeric keyboard to input the desired alarm value. The alarm value is a binary number that is formatted in **Bits** configuration (8-bit, 16-bit or 32-bit). You can input a number

outside the range but when you press **OK**, an error prompt message will be displayed. The instrument can also ignore some digits and alarm when the values of some digits are satisfied. Use "." on the numeric keyboard to set the digits to be ignored and the corresponding position will display "x".

Key Points:

- 1 You must complete the measurement configuration and scaling configuration before configuring the alarm parameters. If you change the measurement configuration or enable scaling function, alarms are turned off and the limit values are cleared.
- 2 If you remove a channel from the scan list, alarms are no longer evaluated on that channel but the limit values are not cleared. If you decide to add that channel back to the scan list, the original limit values are restored and alarms are turned back on.

Advanced Configuration

The fourth step of the channel configuration guide: configure the advanced measurement parameters relating to the function selected.



Figure 2-7 Advanced Configuration

The advanced parameters to be configured differ when different function is selected in the **“Measurement Configuration”** interface for the current channel.

1 Multiplexer Channel

According to the function currently selected, you need to configure the integration time, DC impedance, auto zero, etc. For details, please refer to **“Measurement Parameter Configuration”**.

2 DIO Channel

Select coding mode for the current DIO channel (refer to **“Digital Input”**).

3 TOT Channel

Set the reading mode for the current TOT channel (refer to **“Totalizer”**).

Channel Configuration When Using External DMM

For the multiplexer channels, if the DMM module is not inserted or enabled, you can connect an external DMM to realize scan and measurement function (for the connection method, please refer to “**To Connect Instruments**”).

Press **Config** → **Edit** → **New** to enter into the channel configuration guide which only contains measurement configuration and advanced configuration.

1 Measurement Configuration

After entering into the channel configuration guide, you can select desired channel number and use the up/down direction key to select the **Mode** item and then use the left/right direction key to select desired connection mode.

- **SCAN**: 2-wire connection mode which is supported by all the multiplexer channels.
- **SCAN_4W**: 4-wire connection mode which is supported by the first 16 channels of MC3132 and the first 10 channels of MC3120 and MC3324.

2 Advanced Configuration

Press **Next** to enter the advance configuration interface and set the channel delay time according to “**Channel Delay**”.

Explanation:

In this case, M300 only control the connection mode (2-wire or 4-wire) and the delay time of the channels in the scan list. The function and parameters for each channel are determined by the external DMM.

Measurement Parameter Configuration

This section introduces the measurement parameters (such as the range and integration time) that can be configured in the first and fourth steps of the configuration guide. The parameters available for configuration vary for each measurement function as shown in the table below.

Table 2-1 Measurement Parameter

Function	Parameter		
DCV	Range, Integration Time, Input Impedance, Auto Zero (AZ), Channel Delay		
ACV	Range, AC Filter, Channel Delay		
DCI	Range, Integration Time, Auto Zero (AZ), Channel Delay		
ACI	Range, AC Filter, Channel Delay		
2WR 4WR	Range, Integration Time, Offset Compensation, Auto Zero (AZ), Channel Delay		
FREQ PERIOD	Range, AC Filter, Gate Time, Channel Delay		
TEMP	Type	TC	Model, Unit, Precision, Integration Time, T/C Check, Reference Source, Auto Zero (AZ), Channel Delay
		THER	Model, Unit, Precision, Integration Time, Auto Zero (AZ), Channel Delay
		RTD RTD 4W	RO, ALPHA, Unit, Precision, Integration Time, Offset Compensation, Auto Zero (AZ), Channel Delay
SENSOR	Type	DCV	Unit, Scaling, Integration Time, Input Impedance, Auto Zero (AZ), Channel Delay
		DCI	Unit, Scaling, Integration Time, Auto Zero (AZ), Channel Delay
		2WR 4WR	Unit, Scaling, Integration Time, Offset Compensation, Auto Zero (AZ), Channel Delay
		FREQ	Unit, Scaling, AC Filter, Channel Delay

Note: When the measurement function of the current channel is changed, all the parameters will be restored to their defaults.

To Set the Range

The setting modes of range include “Auto” and “Manual”. In auto range mode, the instrument selects the proper range for each measurement according to the input signal automatically. In the manual range mode, users can select a fixed range for each channel. Auto ranging is convenient and manual ranging provides faster scanning because some additional time is required for the instrument to make a range selection in auto range mode.

Enter the first step of the channel configuration guide, select the desired channel number and function, use the up/down direction key to select **Range** and use the left/right direction key to select the desired range. The ranges available for each function are as shown in the table below.

Table 2-2 Range

Function	Range
DCV/ACV	Auto, 200 mV, 2 V, 20 V, 200 V, 300 V
DCI/ACI	Auto, 200 μ A, 2 mA, 20 mA, 200 mA, 1 A
2WR/4WR	Auto, 200 Ω , 2 k Ω , 20 k Ω , 200 k Ω , 1 M Ω , 10 M Ω , 100 M Ω
FREQ/PERIOD ^[1]	Auto, 200 mV, 2 V, 20 V, 200 V, 300 V

Note^[1]: In frequency/period measurement, the range set is the voltage range of the signal under test and is used to calculate the measurement resolution. The measurement range of frequency/period is from 3 Hz to 1 MHz (1 μ s to 0.33 s).

Key Points:

- Auto range threshold:
For signal under test with voltage/resistance that is between 10%*Range and 110%*Range, the instrument selects Range as the current range automatically. For example, the signal under test for DCV measurement is 5 V (between 10%*20 V and 110%*20 V), the 20 V range is selected automatically.
- If the input signal is greater than the current range, the instrument gives an overrange indication.
- At power-on or after a reset, the range is “Auto” by default.
- “Auto” range is recommended when it is hard to predict the measurement range to protect the instrument and acquire more accurate data.
- For temperature measurements, the instrument internally selects the range. It is not user selectable. For thermocouple measurements, the instrument internally selects the 200 mV range. For thermistor, RTD and RTD 4W measurements, the instrument will autorange to the correct resistance range.

Integration Time

The Integration time is the period of time that the instrument's analog-to-digital (A/D) converter samples the input signal for a measurement. The longer the integration time is, the slower the measurement speed and the better the measurement resolution will be. The shorter the integration time is, the faster the measurement speed and lower the measurement resolution will be. For the relationship between integration time and resolution, please refer to "**Specifications**".

Integration time is applicable to DCV, DCI, 2WR, 4WR, TEMP and SENSOR (except the FREQ sensor) functions. You can specify the integration time in the number of Power Line Cycles and aperture time.

- Number of Power Line Cycles: the unit is PLC. It can be set to 0.02 PLC, 0.2 PLC, 1 PLC, 2 PLC, 10 PLC, 20 PLC, 100 PLC or 200 PLC and the default is 1 PLC. The instrument detects the power frequency automatically at power-on, frequencies within 55 Hz and 66 Hz are regarded as 60 Hz (PLC=1/60 s). Other frequencies are regarded as 50 Hz (PLC=1/50 s).
- Aperture Time: user-defined integration time. The range is from 33 μ s to 4 s.

When the current measurement function is DCV, DCI, 2WR, 4WR, TEMP or SENSOR (except the FREQ sensor), enter the fourth step of the channel configuration guide, use the up/down direction key to select **Integ** and use the left/right direction key to select the desired integration time. The integration time can be set to "User", "0.02PLC", "0.2PLC", "1PLC", "2PLC", "10PLC", "20PLC", "100PLC" and "200PLC". If "User" is selected, you need to use the numeric keyboard to input the desired integration time and then press **OK**. The range is from 33 μ s to 4 s.

Input Impedance

The DC input impedance setting is applicable to DCV and SENSOR (DCV sensor) measurement functions. The default is 10 M Ω . For 200 mV, 2 V and 20 V ranges, you can select ">10 G Ω " to reduce the affect caused by the loading error of the measurement object. The current setting is stored in the volatile memory.

When the current measurement function is DCV or SENSOR (DCV sensor), enter the fourth step of the channel configuration guide, use the up/down direction key to select **IMP** and use the left/right direction key to select the desired impedance.

- **10M**
Set the DC input impedance to 10 M Ω . The input impedances are 10 M Ω on all ranges.
- **>10G**
Set the DC input impedance to >10 G Ω . The input impedances are >10 G Ω on the 200 mV, 2 V and 20 V ranges and are 10 M Ω on the other ranges.

Auto Zero

Auto Zero (AZ) is applicable to DCV, DCI, 2WR, 4WR, TEMP (RTD and RTD 4W) and SENSOR (except FREQ sensor) measurement functions.

When the current function is DCV, DCI, 2WR, 4WR or SENSOR (except FREQ sensor), enter the fourth step of the channel configuration guide, use the up/down direction key to select **AZ** and the left/right direction key to select "ON" or "OFF".

- **ON**

When auto zero is enabled, the DMM internally disconnects the input signal following each measurement and takes a zero reading. It then subtracts the zero reading from the preceding reading (namely, during the measurement, the value displayed is the difference between the measurement value and zero reading). This prevents offset voltages on the instrument's input circuitry from affecting measurement accuracy.

- **OFF**

After pressing "OFF", the auto zero function is disabled. The DMM will still take a zero reading automatically each time the function, range, or integration time is changed and the instrument subtracts this zero reading from the succeeding measurement value.

Tip:

Auto zero and offset compensation are mutually exclusive. After enabling auto zero, offset compensation (if currently enabled) will be disabled automatically and vice versa.

Offset Compensation

The Offset compensation setting is applicable to the 2WR, 4WR, TEMP (RTD and RTD 4W) and SENSOR (2WR sensor and 4WR sensor) measurement functions. It removes the affects of small DC offsets of the measurement lead on the measurement result.

When the current measurement function is 2WR, 4WR, TEMP (RTD or RTD 4W) or SENSOR (2WR sensor or 4WR sensor), enter the fourth step of the channel configuration guide, use the up/down direction key to select **OCOM** and use the left/right direction key to select "ON" or "OFF".

- **ON**
After selecting "ON", add two different currents onto the resistance under test and measure the variation of the voltage between two ends of the resistance. Calculate the resistance under test by dividing the voltage variation by the current variation.
- **OFF**
After selecting "OFF", no offset compensation will be made.

Tip:

Offset compensation and auto zero are mutually exclusive. After enabling offset compensation, auto zero (if currently enabled) will be disabled automatically and vice versa.

AC Filter

AC filter is applicable to the ACV, ACI, FREQ, PERIOD and SENSOR (FREQ sensor) measurement functions. The AC filter optimizes the low frequency accuracy and minimizes the AC settling time. The instrument selects slow, medium or fast filter based on the frequency of the input signal of the current channel as shown in the table below.

Table 2-3 AC Filter Type

Input Frequency	AC Filter Type
3 Hz to 300 kHz	3 Hz (slow)
20 Hz to 300 kHz	20 Hz (medium)
200 Hz to 300 kHz	200 Hz (fast)

When the current measurement function is ACV, ACI, FREQ, PERIOD or SENSOR (FREQ sensor), enter the fourth step of the channel configuration guide, use the up/down direction key to select **Filter** and use the left/right direction key to select "3Hz", "20Hz" or "200Hz". The default is "20Hz".

Gate Time

Gate time (also called Aperture Time) applies to **FREQ** or **PERIOD** function. It decides the resolution of low-frequency measurement. The longer the gate time is, the higher the resolution of the low-frequency measurement is and the slower the measurement is, and vice versa.

When the current measurement function is **FREQ** or **PERIOD**, enter the fourth step of the channel configuration guide, use the up/down direction key to select **GateTime** and use the left/right direction key to select "1ms", "10ms", "100ms" or "1s". The default is "100ms".

Channel Delay

Channel delay is applicable to all the multiplexer channels. Channel delay is the time interval between two neighboring channels during a scan as shown in the figure below. During the scan, the instrument immediately disconnects the previous channel and closes the current channel after finishing measuring the previous channel. The instrument starts the next measurement after the specified channel delay time has been reached.

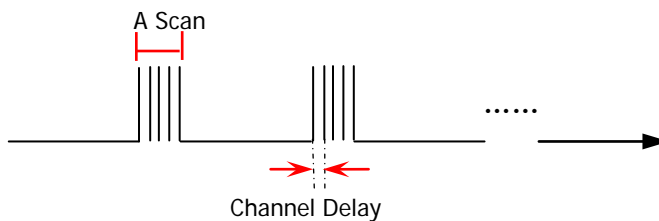

When the current channel is a multiplexer channel, enter the fourth step of the channel configuration guide, use the up/down direction key to select **Delay** and use the left/right direction key to select "Auto" or set a specific delay value.

- **Auto**

In auto mode, the instrument calculates the channel delay according to the function, range, integration time and AC filter of the current channel automatically. At this point, the channel delay time changes each time the configuration of the current channel is changed.

Table 2-4 Auto Delay Time

(a) DCV/DCI/TEMP (TC)/SENSOR (DCV/DCI) (all the ranges):

Integration Time ^[1]	Channel Delay
>1 PLC	2.0 ms
≤1 PLC	1.0 ms

(b) 2WR/4WR/TEMP (THER/RTD/RTD 4W)/SENSOR (2WR/4WR):

Range	Channel Delay (Integration Time > 1 PLC) ^[1]	Range	Channel Delay (Integration Time ≤ 1 PLC)
200 Ω	2.0 ms	200 Ω	1.0 ms
2 kΩ	2.0 ms	2 kΩ	1.0 ms
20 kΩ	2.0 ms	20 kΩ	1.0 ms
200 kΩ	25 ms	200 kΩ	20 ms
1 MΩ	30 ms	1 MΩ	25 ms
10 MΩ	200 ms	10 MΩ	200 ms
100 MΩ	200 ms	100 MΩ	200 ms

Note^[1]: For DCV, TEMP, 2WR, 4WR and SENSOR (except FREQ sensor), if the current integration time is set to "User", the instrument calculates the channel delay according to the condition "Integration Time > 1 PLC" automatically.

(c) ACV/ACI (all the ranges):

AC Filter	Channel Delay
3 Hz (slow)	7.0 s
20 Hz (medium)	1.0 s
200 Hz (fast)	120 ms

(d) FREQ/PERIOD/SENSOR (FREQ):

AC Filter	Channel Delay
3 Hz (slow)	600 ms
20 Hz (medium)	300 ms
200 Hz (fast)	100 ms

- **Delay**

Use the numeric keyboard to enter the desired delay. The range is from 0 to 60 s and the resolution is 1 ms.

Temperature Measurement Parameters

The parameters to be set in temperature measurement are as shown in Table 2-1. Wherein, for the integration time, offset compensation and channel delay, refer to the introduction in the preceding section. This section introduces the configuration methods of the other parameters.

1 Select the temperature sensor type

Enter the first step of the channel configuration guide, select the desired channel number and function (TEMP), use the up/down direction key to select **Type** and use the left/right direction key to select the desired sensor type.

- TC: thermocouple
- THER: thermistor
- RTD: thermal resistance, 2-wire connection mode
- RTD 4W: thermal resistance, 4-wire connection mode, not applicable to single-ended multiplexer

2 To select the unit

Use the up/down direction key to select **Unit** and the left/right direction key to select the desired unit. The M300 can report temperature measurements in °C (Celsius), °F (Fahrenheit) and K (Kelvins). The temperature conversion relations are as shown below.

$$^{\circ}F = (9/5) \times ^{\circ}C + 32$$

$$K \approx ^{\circ}C + 273.15$$

Different channels on the same module can use different temperature units.

3 Use Thermocouple to Measure Temperature

The thermocouple is one of the most commonly used devices for measuring temperature in industry. It converts temperature variation information into voltage variation information. It provides larger temperature measurement range.

- **Model**

After setting the temperature sensor type to TC, use the up/down direction key to select **Model** and use the left/right direction key to select the desired model.

The M300 supports the following thermocouple types: B (Pt Rh 30- Pt Rh6), E (NI CR-WRCK), J (Fe-WRCK), K (NI CR-NiSi), N (NiCrNi-NiSi), R (Pt Rh13 -Pt), S (Pt Rh10-Pt) and T (Cu-WRCK). Among them, B, R and S are precious metal thermocouples. E, J, K, N and T are low cost metal thermocouples. For the reference table about each thermocouple, please refer to the ITS-90 (International Temperature Scale of 1990) standards.

- **Precision**

After setting the temperature sensor type to TC, use the up/down direction key to select **Precision** and use the left/right direction key to select "1" or "0.1".

- **T/C Check**

The T/C Check (Thermocouple Check) function checks whether the TC is connected correctly. After setting the temperature sensor type to TC, enter the fourth step of the channel configuration guide, use the up/down direction key to select **T/C Check** and use the left/right direction key to select "ON" or "OFF". When "ON" is selected, the instrument measures the channel resistance (in the 20 k Ω range) automatically after each thermocouple measurement to ensure a proper connection. If an open connection is detected (greater than 5 k Ω), the instrument displays "OPEN T/C".

- **Reference Source**

Thermocouple measurements require a reference junction temperature.

After setting the temperature sensor type to TC, enter the fourth step of the channel configuration guide, use the up/down direction key to select **Ref** and use the left/right direction key to select "Fixed", "Internal" or "External".

- a) Fixed: select a fixed reference temperature. Then use up/down direction key to select **Fixed** and use the numeric keyboard to input desired temperature. The range is from -20 $^{\circ}\text{C}$ to 80 $^{\circ}\text{C}$ (always specify the temperature in $^{\circ}\text{C}$ regardless of the temperature units currently selected). Using this type of reference source, you can obtain the highest measurement precision.
- b) Internal: select an internal isothermal reference temperature on the module. Using this type of reference source, you will obtain the lowest measurement precision.
- c) External: before selecting external reference, please find the first module which supports temperature measurement function from Slot1. Then configure the first channel of this module to perform a temperature measurement function. The selected type can be THER, RTD or RTD 4W. Otherwise, you cannot select external reference for other channels. This channel is then reserved as the reference source. At this point, you can select other external references for other channels. If this channel is deleted or its function is modified, the channels taking this channel as reference source will revert to the internal reference automatically.

4 Use thermistor to measure temperature

A thermistor is made up of material of which the resistance changes with temperature and it converts temperature variation information to resistance variation information. Thermistor is especially sensitive to temperature but its

temperature measurement range is small and is more suitable for measurements with relatively small temperature variations.

Thermistor resistance is usually very high. Therefore, the 2-wire resistance method is preferred when measuring the resistance of the thermistor. The internal software conversion program converts the resistance measured to the corresponding temperature.

- **Model**
After setting the temperature sensor type to THER, use the up/down direction key to select **Model** and use the left/right direction key to select the desired model (2.2k Ω , 3k Ω , 5k Ω , 10k Ω or 30k Ω).
- **Precision**
After setting the temperature sensor type to THER, use the up/down direction key to select **Precision** and use the left/right direction key to select "1", "0.1" or "0.01".

5 Use RTD to measure temperature

RTD measures the temperature on the basis that the resistance of the measured substance changes with temperature. It features in high measurement accuracy and stable performance.

The instrument can measure the resistance using 2-wire (RTD) or 4-wire (RTD 4W) method. The internal software conversion program converts the resistance measured to the corresponding temperature. For the reference table about each kind of RTD, please refer to the related standards.

- **R0**
After setting the temperature sensor type to RTD or RTD 4W, use the up/down direction key to select **R0** and use the numeric keyboard to input the desired resistance. The range is from 49 Ω to 2100 Ω and the default is 100 Ω .
- **ALPHA**
Temperature coefficient.
After setting the temperature sensor type to RTD or RTD 4W, use the up/down direction key to select **ALPHA** and use the left/right direction key to select the desired coefficient (0.00385, 0.00389, 0.00391 or 0.00392).
- **Precision**
After setting the temperature sensor type to RTD or RTD 4W, use the up/down direction key to select **Precision** and use the left/right direction key to select "1", "0.1" or "0.01".

Tip:

For the temperature measurement principles of thermocouple, RTD and thermister, refer to the *Temperature Measurement Technique Application Instruction* (contact **RIGOL** to acquire the manual).

Any Sensor Measurement Parameters

Any sensor measurement supports DCV, 2WR, 4WR and FREQ sensors. With the any sensor measurement function, you can easily convert the measured quantity (pressure, flow, temperature, etc.) to quantity that is easy to measure (voltage, resistance, etc.). After inputting the response curve, the instrument converts and amends the data according to the internal arithmetic to obtain the physical quantity measured. Users can edit and modify the display unit of the measured physical quantity at will. The parameters for the any sensor measurement function are as shown in Table 2-1. Wherein, the integration time and AC filter are introduced in the preceding section and this section introduces the configuration methods of the other parameters.

1 Select the sensor type

Enter the first step of the channel configuration guide, select the desired channel number and function (SENSOR), use the up/down direction key to select **Type** and use the left/right direction key to select the desired type (DCV, DCI, 2WR, 4WR or FREQ).

2 Set the unit

Use the up/down direction key to select **Unit** and use the left/right direction key to select the desired unit ($^{\circ}$, $^{\circ}\text{C}$, $\%$, $^{\circ}\text{F}$, Ω or K).

You can also define a unit. Select "User" and press **OK** to enter the filename input interface. Input the desired unit and press **OK**. The length of user-defined unit cannot exceed 3 characters.

3 Configure the arithmetic curve

Use the up/down direction key to select **Scaling** and " Ax^2+Bx+C " is displayed by default. Press **OK** to open the configuration list interface. The arithmetic between the first start value and the second start value conforms to the first fitting function, the arithmetic between the second start value and the third start value conforms to the second fitting function,, from the last start value on, the arithmetic conforms to the last fitting function.

● Add

This menu is used to add the start value and fitting function. Press this softkey to open the any sensor configuration interface.

Start Value: use the up/down direction key to select **Start** and use the numeric keyboard to input the desired value between $-1\text{E}+15$ and $1\text{E}+15$.

Fitting Function Coefficients: use the up/down direction key to select **A**, **B** and **C** respectively and use the numeric keyboard to input the desired values between $-1\text{E}+15$ and $1\text{E}+15$.

Start Value and Coefficient Setting Explanation:

When setting the start value and fitting function coefficients (A, B and C), press any key on the numeric keyboard to open the dialog box in the form below.

- **Sign:** use the left direction key to move the cursor to the sign bit and press $\boxed{+/-}$ on the numeric keyboard to switch the sign to "+" or "-".
- **Unit:** use the right direction key to move the cursor to the unit bit and use the up/down direction key to select the desired unit. The units available are related to the sensor type currently selected. The unit coefficients include n (10^{-9}), u (10^{-6}), m (10^{-3}), _ (1), K (10^3), M (10^6), G (10^9), T (10^{12}) and P (10^{15}).
- **Number:** use the left/right direction key to move the cursor to the number bit and use the numeric keyboard to input the desired value.

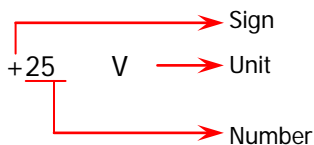

After configuring a group of start value and fitting function, press **Done** to return to the arithmetic curve configuration list interface. Press **Add** again to configure the next group of start value and fitting function.

- **Delete**
Use the up/down direction key to select a group of start value and fitting function in the arithmetic curve configuration list interface and press **Delete** to delete the configuration selected.
- **Modify**
Use the up/down direction key to select a group of start value and fitting function in the arithmetic curve configuration list interface and press **Modify** to enter the any sensor configuration interface. At this point, you can modify this group of configuration.
- **Done**
Finish the arithmetic curve configuration and return to the measurement configuration interface.
- **Return**
Give up the configuration currently edited and return to the measurement configuration interface.

Digital Input

The multifunction module has four non-isolated 8-bit digital input/output (DIO) ports which you can use as digital output ports (refer to “**Module Control**”) and digital input ports. When used as digital input ports, you can read the real-time status of each bit of the ports and read the digital signal automatically by configuring the DIO channels into the scan list via the channel configuration guide (or press **Control** and use the left/right direction key to select the multifunction module and the press **Config**).

DIO channel configuration guide includes “Measurement Configuration”, “Alarm Configuration” and “Advanced Configuration”. For alarm configuration, refer to “**Alarm Configuration**”. This section introduces the parameters to be set in “Measurement Configuration” and “Advanced Configuration” for the DIO channels.

1 Chan No.

Enter the first step of the channel configuration guide. Use the up/down direction key to select **Chan No.** and use the numeric keyboard to input or use the left/right direction key to select the desired channel number. Generally, the DIO channels are numbered “S01” to “S04” where S denotes the slot number of the multifunction module.

2 Function

After selecting the correct channel number, **Function** is fixed to “DIO” and users cannot modify it.

3 Status

Use the up/down direction key to select **Status** and use the left/right direction key to select the desired status.

- **READ**: configure the current DIO channel to the scan list. At this point, this channel can only be used as a digital input port. During a scan, the instrument can read the digital signal of this channel.
- **OFF**: do not configure the current DIO channel to the scan list. At this point, this channel can be used as both digital input (you can read the digital input signal of this port manually) and digital output port (you can edit the digital output signal of this port). Please refer to the introduction in “**To Control MC3534**”.

4 Bits

Use the up/down direction key to select **Bits** and use the left/right direction key to select the desired number of bits. Channels “S01” to “S04” are all 8-bit ports. You can configure the 4 channels to be independent 8-bit channels. You can also combine “S01” and “S02” as well as “S03” and “S04” respectively and configure them to 16-bit. Finally, all 4 channels can be combined and configured to be 32-bit input.

8-bit	S01 XXXXXXXX	S02 XXXXXXXX	S03 XXXXXXXX	S04 XXXXXXXX
16-bit	S02S01 XXXXXXXXXXXXXXXXXX		S04S03 XXXXXXXXXXXXXXXXXX	
32-bit	S04S03S02S01 XX			

Note: In the 16-bit S02S01, S02 is the upper 8-bit bank. In the 16-bit S04S03, S04 is the upper 8-bit bank. In the 32-bit S04S03S02S01, S04 is the upper 8-bit bank.

5 Type

When the channel status is READ, use the up/down direction key to select **Type** and use the left/right direction key to select the desired level (“TTL”, “CMOS5V”, “CMOS3.3V”, “CMOS2.5V” or “User”). If “User” is currently selected, use the up/down direction key to select **Level** and **Threshold** respectively and use the numeric keyboard to input the desired values.

- The range of level is from 2.000 V to 5.000 V and the default is 5.000 V.
- The range of threshold is from 0.500 V to 3.500 V and the default is 2.500 V.
- When setting the level and threshold, they should fulfill the relation equation: $Level \geq Threshold + 0.5 V$.
- When the input signal $< Threshold - 0.3 V$, it is regarded as logic 0; when the input signal $> Threshold + 0.3 V$, it is regarded as logic 1.

6 Coding

Enter the fourth step of the channel configuration guide. By default, **Coding** is selected and use the left/right direction key to select “Binary”, “Decimal” or “Hex”.

The coding mode selected will be used in both the digital input and output of this channel.

Key Points:

- 1 When the DIO channels are used as digital input channels, they do not have to be part of the scan list and the DMM module does not have to be enabled to generate an alarm when the reading matches or does not match the specific data pattern.
- 2 DIO channels added into the scan list cannot be used as digital output channels.

Totalizer

The multifunction module provides four 32-bit totalizers (TOT) which can count TTL pulses at a 10 MHz rate (for high-speed TOT channels) or 100 kHz rate (for normal TOT channels). You can manually read the TOT count or you can read the TOT count automatically by configuring the TOT channels to a scan list via the channel configuration guide.

The TOT channel configuration guide contains "Measurement Configuration", "Alarm Configuration" and "Advanced Configuration". For alarm configuration, refer to "**Alarm Configuration**". This section introduces the parameters to be set in "Measurement Configuration" and "Advanced Configuration" for the TOT channels.

1 Chan No.

Enter the first step of the channel configuration guide. Use the up/down direction key to select **Chan No.** and use the numeric keyboard to input or use the left/right direction key to select the desired channel number.

Generally, the TOT channels are numbered "S05" to "S08" where S denotes the current slot number of the multifunction module. "S05" and "S06" are high-speed TOT channels and can count TTL pulses at a 10 MHz rate. "S07" and "S08" are normal TOT channels with 100 kHz count rate.

2 Function

After selecting the correct channel number, **Function** is fixed at "TOT" and users cannot modify it.

3 Status

Use the up/down direction key to select **Status** and use the left/right direction key to select the desired status.

- **READ**: configure the current TOT channel to the scan list. During a scan, the instrument can read the current TOT count.
- **OFF**: do not configure the current TOT channel to the scan list. You can start and stop the counting or read the count of the TOT channel manually. Please refer to the introduction in "**To Control MC3534**".

4 TrigMode

When the channel status is READ, use the up/down direction key to select **TrigMode** and use the left/right direction key to select the desired mode.

- **Rising**: configure the totalizer to count on the rising edge of the input signal when the input signal passes through the trigger threshold.
- **Falling**: configure the totalizer to count on the falling edge of the input signal when the input signal passes through the trigger threshold.

Note: The "TrigMode" here refers to the mode in which to trigger the counting of the totalizer. Please pay attention to distinguish it from the "TrigMode" of the

instrument.

5 Threshold

For TOT channels "S07" and "S08", after selecting the trigger mode, use the up/down direction key to select **Threshold** and use the numeric keyboard to input the desired value between -12 V and +12 V.

Note: This function is only applicable to TOT channels "S07" and "S08". For TOT channels "S05" and "S06", the threshold is fixed at CMOS 3.3 V.

The terminal block of the multifunction module provides G and G# terminals which are used to control the trigger of the TOT channels.

- A TTL high level applied to the G terminal and a TTL low level applied to the G# terminal enables counting.
- Only providing a TTL high level applied to the G terminal enables counting.
- Only provide a TTL low level applied to the G# terminal enables counting.
- When a gate signal is not detected in both the terminals, counting is always enabled.

6 Read

Enter the fourth step of the channel configuration guide. Use the up/down direction key to select **Read** and use the left/right direction key to select the desired setting.

- READ&RST: read the count and reset the totalizer without losing any counts.
- READ: only read the count.

Key Points:

- 1 The maximum count is 4294967295 ($2^{32}-1$). The count rolls over to 0 after reaching the maximum allowed value.
- 2 You can configure the instrument to generate an alarm in the specified alarm channel when a specific count is reached for TOT channel that is not added to the scale list (the channel status is OFF). Please refer to "**Alarm Configuration**" to configure the desired parameters.
- 3 You can execute single-channel monitor on a TOT channel even if the channel is not part of the scan list (the channel status is OFF).
- 4 "S05" and "S06" are high-speed TOT channels with 10 MHz count rate; they only receive standard TTL pulse or 3.3 V to 5 V square signal and their thresholds are decided by the internal circuit. "S07" and "S08" are normal TOT channels with 100 kHz count rate. They can receive analog signal or TTL pulse and their thresholds are set by users (the range is from -12 V to +12 V).

Configuration Copy

The configuration copy function supports module copy, channel copy and extended copy. Press **Config** → **Edit** → **Copy** to enter the copying interface.

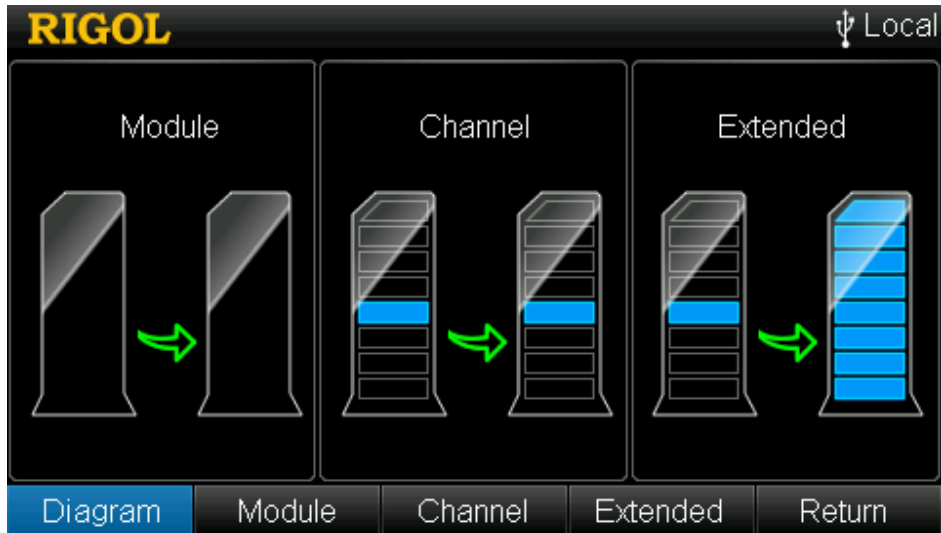

Figure 2-8 Configuration Copy

Module Copy

Module copy can copy the configuration of a module (source module) to another module (target module) of the same model. After that, the configuration of each channel of the source module is copied to the target module automatically.

Press **Module** to enter the module copy interface.

- Switch: switch the cursor between the “Source Module” and “Target Module” areas.
- OK: copy the configuration of the source module selected to the target module selected.
- Return: return to the upper-level menu.

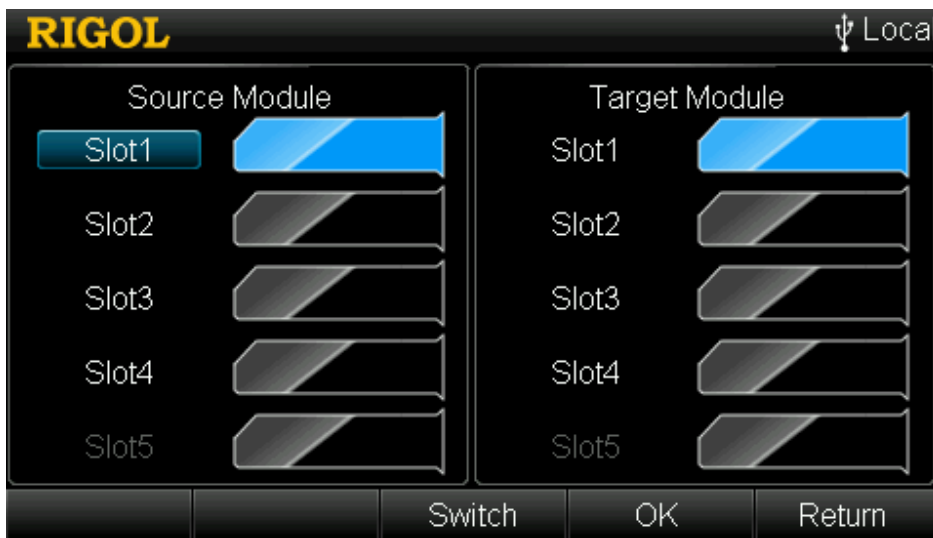

Figure 2-9 Module Copy

Steps of Module Copy:

- 1 After entering the module copy interface, the “Source Module” area is selected by default. Use the up/down direction key to select the desired source module.
- 2 Press **Switch** to move the cursor to the “Target Module” area and use the up/down direction key to select the desired target module.
- 3 Press **OK** to execute module copy.

Note: The source module and target module selected must be of the same model and it is forbidden to copy the configuration of a module to itself.

Channel Copy

Channel copy can copy the configuration of a channel (source channel) to another channel or multiple channels (target channels) of the same type. After that, the following settings of the source channel are copied to the target channels automatically.

- 1 Measurement Configuration: include measurement function, range, etc.
- 2 Scaling Setting: on/off status of the scaling function and scaling coefficients.
- 3 Alarm Setting: on/off status of the alarm function, alarm channel number and alarm limits.
- 4 Advanced Configuration: include integration time, AC filter, etc.

Press **Channel** to enter the channel copy interface. This interface is divided into the upper and lower areas.

- Switch: switch the cursor to select desired area. This menu is available only when the current scan list has 2 or more channels.
- Upper Area: use the channel selected as the source channel. You can select the target channels.
- Lower Area: use the channel selected as the target channel. You can select the source channel.
- Done: copy the configuration of the source channel selected to the target channel selected.
- Return: return to the upper-level menu.

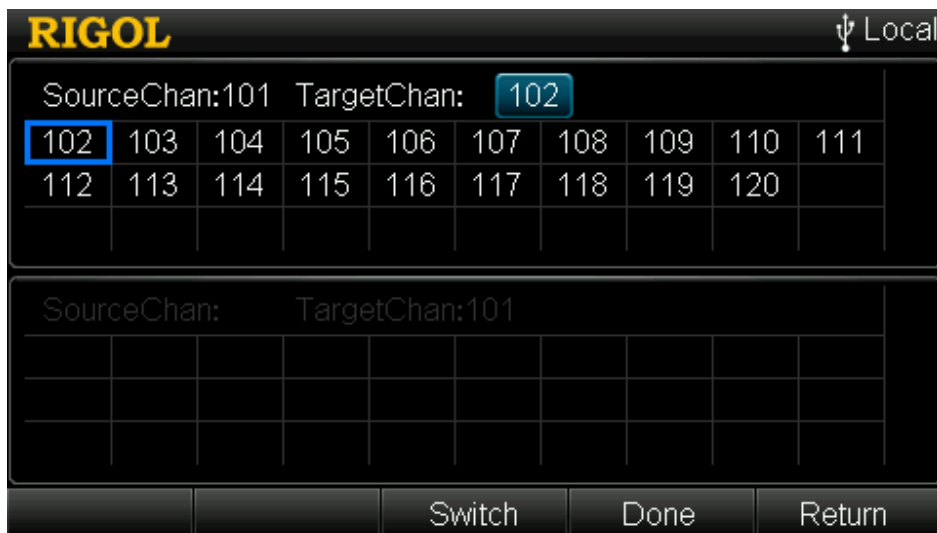

Figure 2-10 Channel Copy

Steps of Channel Copy:

After entering the channel copy interface, the channel selected is fixed as the source channel and the upper area is selected by default. Use the left/right direction key to select the desired target channels, press **OK** to confirm it (press **OK** again to cancel

it) and press **Done** to execute the channel copy.

You also can press **Switch** to fix the channel selected as the target channel after entering the channel copy interface. At this point, the lower area is selected. Use the left/right direction key to select the desired source channel and press **Done** to execute channel copy.

Tips:

1. When the channel selected is fixed as the source channel, multiple target channels can be selected and are displayed in the lower area.
2. When the channel selected is fixed as the target channel, only one source channel can be selected.
3. The **Switch** menu is gray and disabled if the scan list only has one channel.

Note: For channel copy, only copies between the same type of channels are allowed.

Extended Copy

Extended copy allows copying the configuration of a channel (source channel) of a module to all the channels (which type is the same to that of the source channel) of the target module. After that, the following settings will be copied to the target module automatically.

- 1 Measurement Configuration: include measurement function, range, etc.
- 2 Scaling Setting: on/off status of the scaling function and scaling coefficients;
- 3 Alarm Setting: on/off status of the alarm function, alarm channel number and alarm limits;
- 4 Advanced Configuration: include integration time, AC filter, etc.

Press **Extended** to enter the extended copy interface.

- Switch: switch the cursor between the “Source Channel” area and “Target Module” area.
- OK: copy the configuration of the source channel selected to the target module selected.
- Return: return to the upper-level menu.



Figure 2-11 Extended Copy

Steps of Extended Copy

- 1 After entering the extended copy interface, the “Source Channel” area is selected by default. Use the direction keys to select the desired source channel.
- 2 Press **Switch** to move the cursor to the “Target Module” area and use the up/down direction key to select the desired target module.
- 3 Press **OK** to execute extended copy.

Note:

For extended copy, only copies among the same type of modules are allowed. This function makes it easy to configure several channels for the same measurement.

Channel Monitor

The channel monitor function of M300 allows users to monitor a single channel, multiple channels, or all of the channels in the scan list. The instrument monitors the channel and takes readings from the channel monitored continuously even during a scan. This function is helpful for troubleshooting your system before a test or for watching an important signal.

The channel monitor function can monitor the following channels: multiplexer channels (configured to the scan list and the DMM module is enabled), DIO and TOT channels of the multifunction module (no matter whether they are configured to the scan list and the DMM module is not required).

Press **Monitor** at the front panel to configure the channel monitor function.

Single-channel Monitor

Press **Monitor** → **Single** to enter the single-channel monitor interface as shown in Figure 2-12 and by default, the first channel in the scan list is monitored. If no scan list is currently configured, the first channel of the multifunction module (DIO channel) is monitored.

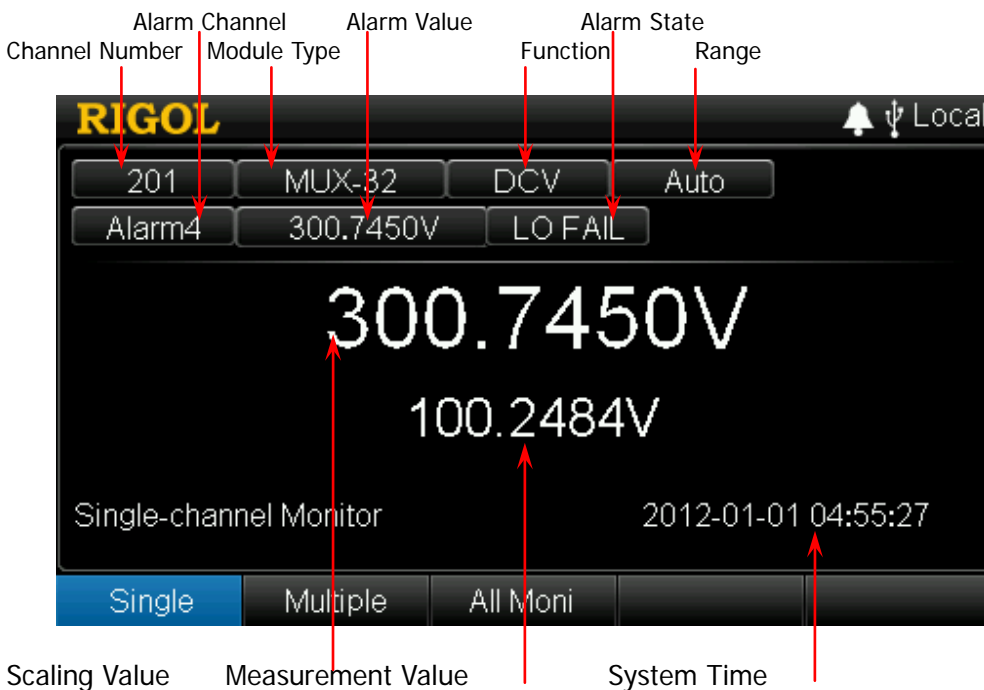

Figure 2-12 Single-channel Monitor

1 Channel Number

The channel number is in the editable status. At this point, you can modify the number of the channel monitored by inputting the desired channel number using the numeric keyboard (you can also press **Single** at the front panel to switch the channel monitored).

Note: If the channel number of the multiplexer channel that is not added into the scan list is input, the instrument will generate an error prompt message.

2 Module Type

Display the module type of the channel currently monitored.

MUX-20: 20-Channel Multiplexer and its model is MC3120

MUX-32: 32-Channel Multiplexer and its model is MC3132

MUX-64: 64-Channel Single-Ended Multiplexer 64 and its model is MC3164

MUX-MIX-24: 24-Channel Multiplexer and its model is MC3324

MFC: Multifunction Module and its model is MC3534

3 Function

Display the function (DCV, ACV, DCI, ACI, 2WR, 4WR, FREQ, PERIOD, TEMP, SENSOR, DIN or TOT) of the channel currently monitored.

4 Range

Display the range of the channel currently monitored. This is only applicable to multiplexer channels.

5 Scaling Value

Display the scaling value of the channel currently monitored (only when the current channel uses the scaling function).

6 Measurement Value

Display the measurement value of the channel currently monitored. For TOT channel, the count value is displayed. If the current channel does not use the scaling function (the scaling value is not displayed), the measurement value is displayed at the center of the screen in relatively larger font size.

7 Alarm Channel/Alarm Value/Alarm State

Display the alarm information of the channel currently monitored, including the alarm channel, alarm value (displayed only when alarm is generated) and alarm state (PASS, LO FAIL or HI FAIL). For DIO channels, the alarm state can be PASS, EQU FAIL or NOT EQU FAIL. If the channel monitored does not use the alarm function, "ALARM NO CONFIGURE" will be displayed.

8 System Time

Display the system time.

Key Points:

- 1 For single-channel monitor function, only one channel can be monitored at a time, but you can change the channel being monitored at any time.
- 2 Readings acquired during a monitor are not stored in memory but they are displayed on the screen.
- 3 When the alarm function are applied to the selected channel during monitor, all the alarm data is stored in the alarm queue (which will be cleared at power-off).
- 4 You can monitor a multiplexer channel only if the DMM module is installed and enabled (**Utility** → **DMM** → "ON"). The channel must also be configured to be part of the scan list.
- 5 You can monitor a DIO or TOT channel even if the channel is not part of the scan list.

Multi-channel Monitor

Press **Monitor** → **Multiple** to enter the multi-channel monitor interface. At most 7 channels can be monitored. You can add or delete the channels being monitored.

- Add: use the numeric keyboard to input the channel number.
- Delete: use the up/down direction key to select the desired channel number and then press **Delete**.

All Channel Monitor

Press **Monitor** → **All Moni** to enter the all channel monitor interface. All channels in the scan list can be monitored.

Module Control

The M300 provides a user-friendly module control interface. Press **Control** at the front panel to enter the interface as shown in Figure 2-13. You can control the status of each module (except the DMM module).

The 5 column diagrams in the module control interface represent the 5 slots. The corresponding number (such as slot1) and type of the module inserted into the slot are displayed above and below the column diagram respectively and the name of the module is displayed in the middle of the column diagram. Use the left/right direction key to select the desired module (slot without module and slot with the DMM module cannot be selected). The module currently selected is displayed in blue. Press **Single** to enter the control interface of the module currently selected.

Note: In the module control interface, the model and name of the module are related to the module currently inserted into the instrument.

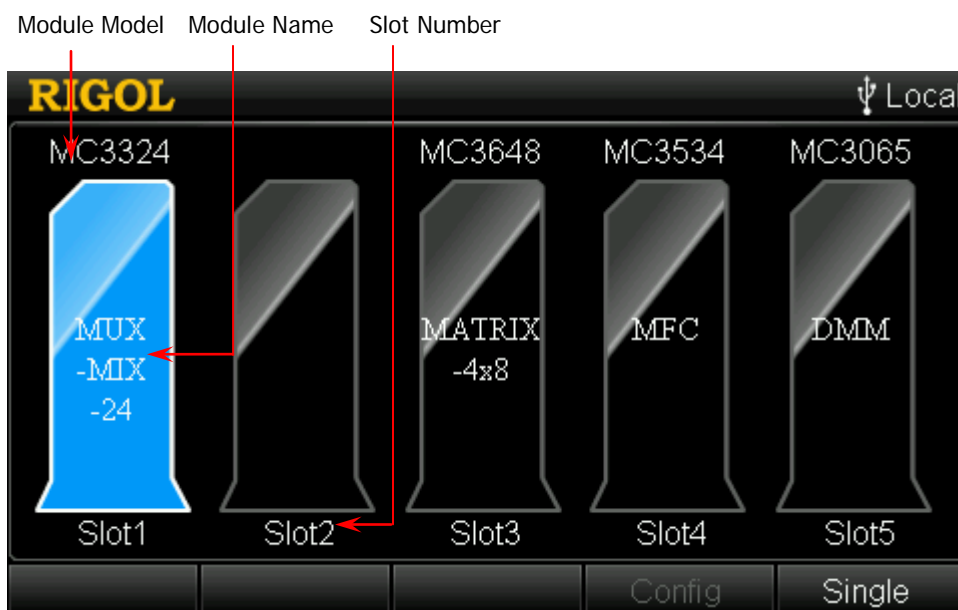

Figure 2-13 Module Control Interface

Explanation:

When the multiplexer is used as the DMM input channel, only one channel can be closed at each time. For example, use channel 1 of MC3132 to measure temperature and channel 2 to measure DCV. The instrument first closes channel 1 to measure temperature, and then disconnects channel 1 and closes channel 2 to measure DCV (namely, the "break-before-make" feature).

To Control MC3120

MC3120 is a 20-channel multiplexer (MUX-20 for short). MC3120 is divided into two banks of 10 two-wire channels (HI and LO) each and can be used for 2-wire and 4-wire connections. When making 4-wire resistance measurement, the instrument automatically pairs channel n with channel $n+10$ (wherein, n is an integer between 1 and 10). MC3120 is used with the external terminal block (M3TB20) which has a built-in thermocouple reference junction.

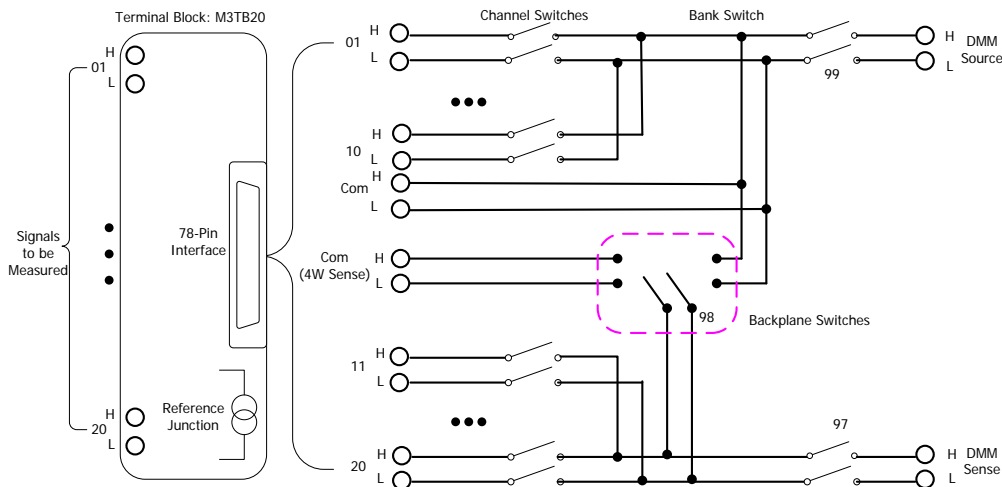

Figure 2-14 MC3120 Schematic Diagram

The control interface of MC3120 is as shown in Figure 2-15. Use the up/down and left/right direction keys to select the desired channel. The channel currently selected is highlighted, for example, **01**. You can perform various operations on the channel currently selected (such as open or close the channel).

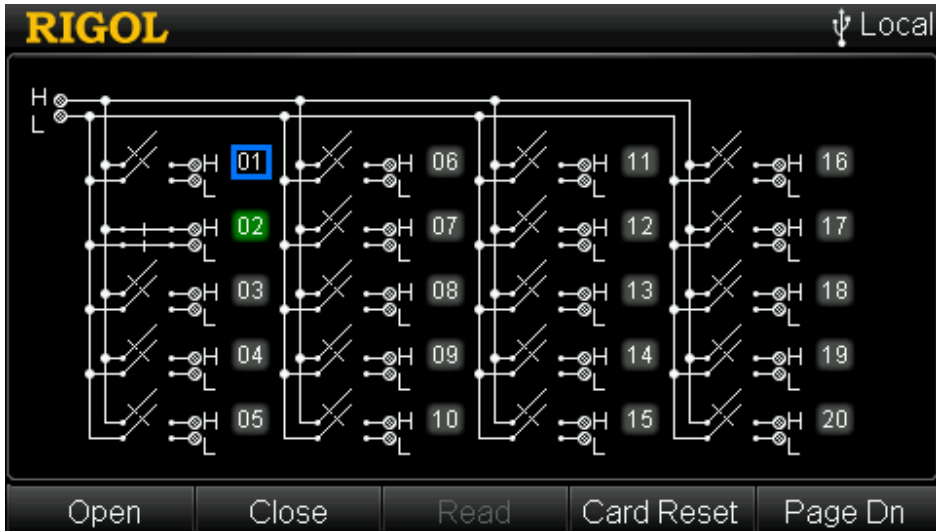

Figure 2-15 MC3120 Control Interface (Bank Joined)

If the channel currently selected is not added to the scan list and other channels of the module are not added to the scan list, pressing **OK** can close the channel. At this point, pressing **OK** again can open the channel. If the channel is added to the scan list, pressing **OK** can close the channel and read the measurement result (before closing this channel, the instrument opens the channel currently closed). Pressing **OK** again can read the measurement result again.

1 Open

Disconnect the channel currently selected. The channel number of the channel currently disconnected is displayed in gray, for example, 03. If one or more channels of the current module are added to the scan list, this operation is invalid.

2 Close

Close the channel currently selected. The channel number of the channel currently closed is displayed in green, for example, 02. If one or more channels of the current module are added to the scan list, this operation is invalid.

3 Read

Read the measurement value of the current channel. This operation is only applicable to channels added to the scan list.

4 Card Reset

Initialize the status of each channel of the current module. If one or more channels of the current module are added to the scan list, this operation is invalid.

5 Bank Separate/Bank Joined

By default, this module is in “Bank Joined” state (namely the bank switch in Figure 2-14 is closed and the control interface is as shown in Figure 2-15). At this point, this module can only be used for 2-wire connection. Press **Page Dn** → **Bank Sepa** to execute the “Bank Separate” operation (namely disconnect the bank switch in Figure 2-14 and the control interface is as shown in Figure 2-16). At this point, this module is divided into two independent banks and can be used for 4-wire connection. When it is used for 4-wire resistance measurement, the instrument pairs channel n and channel $n+10$ automatically (wherein, n is an integer between 1 and 10). Channel n is used to connect the source terminal of DMM and channel $n+10$ is used to connect the sense terminal of DMM.

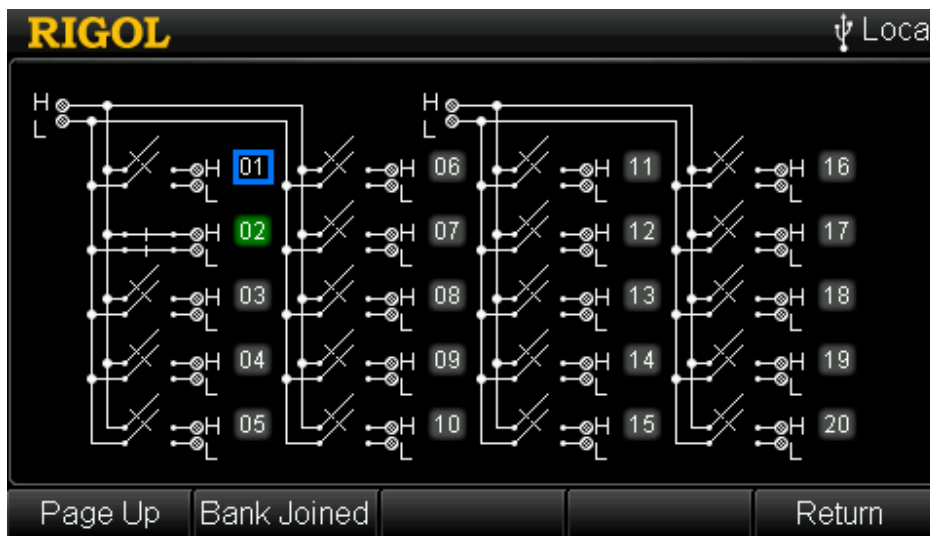

Figure 2-16 MC3120 Control Interface (Bank Separate)

To Control MC3132

MC3132 is a 32-channel multiplexer (MUX-32 for short). MC3132 is divided into two banks of 16 two-wire channels (HI and LO) each and can be used for 2-wire and 4-wire connections. When making 4-wire resistance measurement, the instrument automatically pairs channel n with channel $n+16$ (wherein, n is an integer between 1 and 16). MC3132 is used with the external terminal block (M3TB32) which has a built-in thermocouple reference junction.

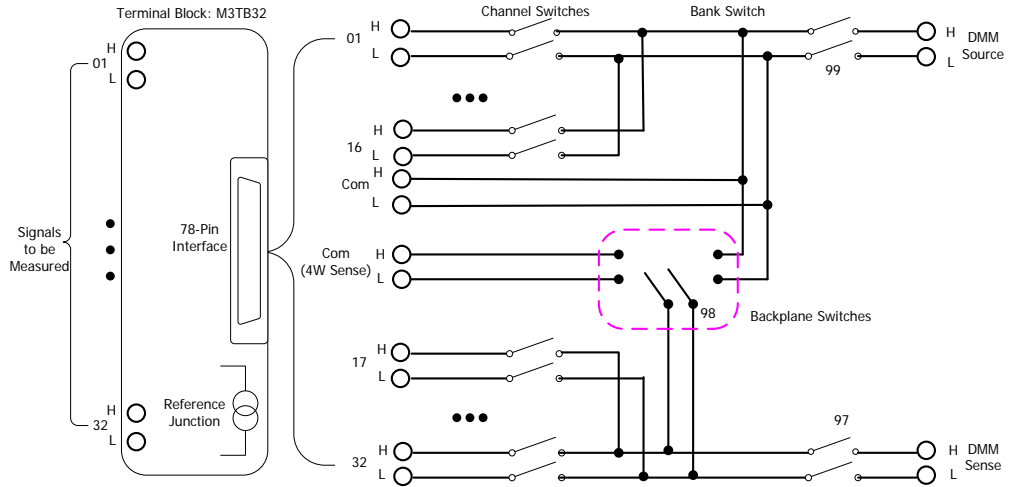

Figure 2-17 MC3132 Schematic Diagram

The control interface of MC3132 is as shown in Figure 2-18. Use the up/down and left/right direction keys to select the desired channel. The channel currently selected is highlighted, for example, **01**. You can perform various operations on the channel currently selected (such as disconnect and close the channel).

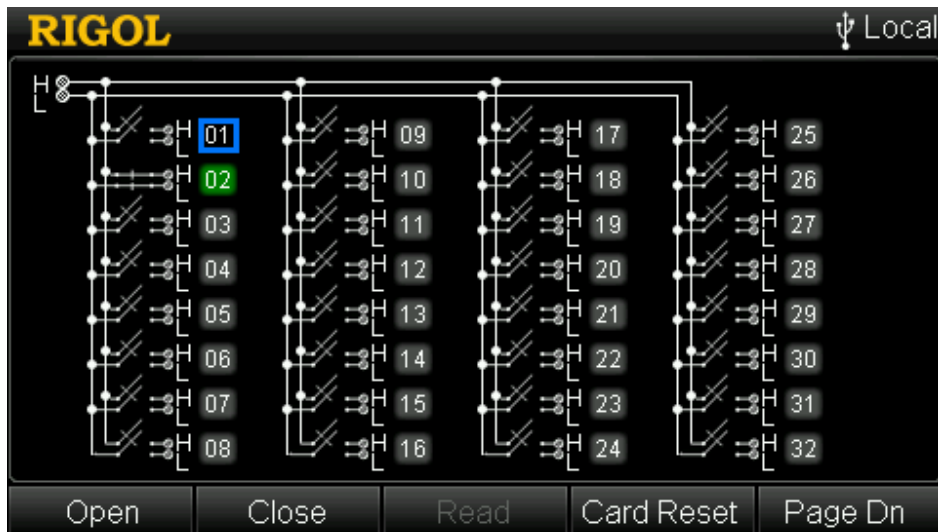

Figure 2-18 MC3132 Control Interface (Bank Joined)

If the channel currently selected is not added to the scan and other channels of the module are not added to the scan list, pressing **OK** can close the channel. At this point, pressing **OK** again can open the channel. If the channel is added to the scan list, pressing **OK** can close the channel and read the measurement result (before closing this channel, the instrument opens the channel currently closed). Pressing **OK** again can read the measurement result again.

1 Open

Disconnect the channel currently selected. The channel number of the channel currently disconnected is displayed in gray, for example, 03. If one or more channels of the current module are added to the scan list, this operation is invalid.

2 Close

Close the channel currently selected. The channel number of the channel currently closed is displayed in green, for example, 02. If one or more channels of the current module are added to the scan list, this operation is invalid.

3 Read

Read the measurement value of the current channel. This operation is only applicable to channels added to the scan list.

4 Card Reset

Initialize the status of each channel of the current module. If one or more channels of the current module are added to the scan list, this operation is invalid.

5 Bank Separate/Bank Joined

By default, this module is in “Bank Joined” state (namely the bank switch in Figure 2-17 is closed and the control interface is as shown in Figure 2-18). At this point, this module can only be used for 2-wire connection. Press **Page Dn** → **Bank Sepa** to execute the “Bank Separate” operation (namely disconnect the bank switch in Figure 2-17 and the control interface is as shown in Figure 2-19). At this point, this module is divided into two independent banks and can be used for 4-wire connection. When it is used for 4-wire resistance measurement, the instrument pairs channel n and channel $n+16$ automatically (wherein, n is an integer between 1 and 16). Channel n is used to connect the source terminal of DMM and channel $n+16$ is used to connect the sense terminal of DMM.

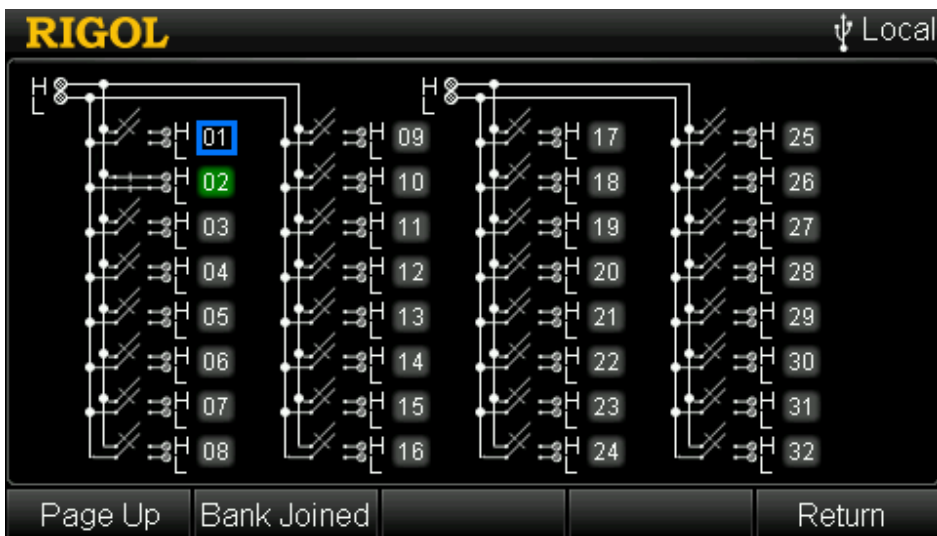

Figure 2-19 MC3132 Control Interface (Bank Separate)

To Control MC3164

MC3164 is a 64-channel single-ended multiplexer (MUX-64 for short). MC3164 is divided into two banks of 32 single-ended channels (HI only, the 32 channels has a common LO terminal) each and cannot be used for 4-wire connection. MC3164 is used with the external terminal block (M3TB64) which has a built-in thermocouple reference junction.

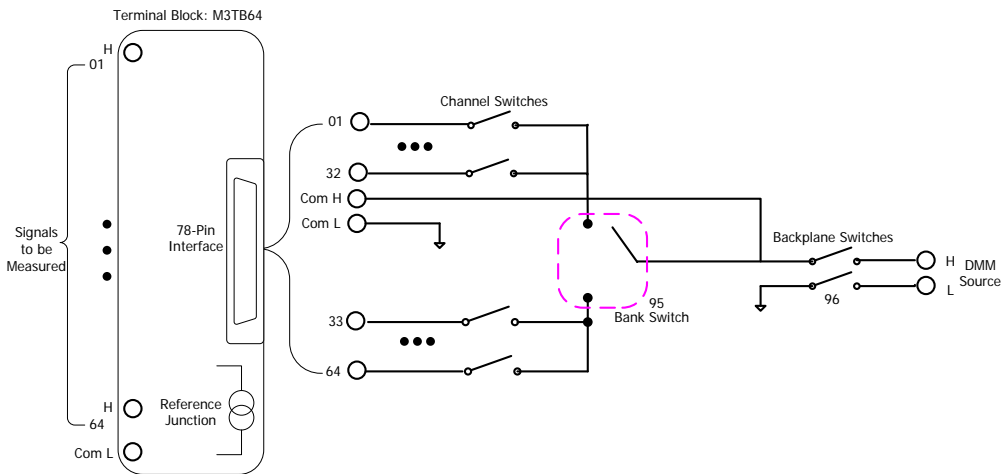

Figure 2-20 MC3164 Schematic Diagram

The control interface of MC3164 is as shown in Figure 2-21. Press **Page Up** and **Page Dn** at the front panel to open the previous and next pages of the control interface. Use the up/down and left/right direction keys to select the desired channel. The channel currently selected is highlighted, for example, **01**. You can perform various operations on the channel currently selected (such as disconnect and close the channel).

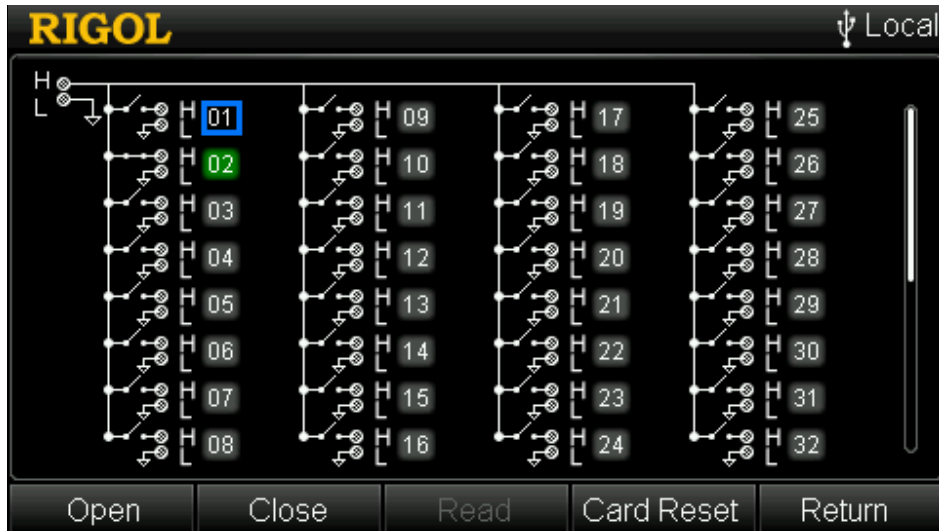

Figure 2-21 MC3164 Control Interface

If the channel currently selected is not added to the scan list and other channels of the module are not added to the scan list, pressing **OK** can close the channel. At this point, pressing **OK** again can open the channel. If the channel is added to the scan list, pressing **OK** can close the channel and read the measurement result (before closing this channel, the instrument opens the channel currently closed). Pressing **OK** again can read the measurement result again.

1 Open

Disconnect the channel currently selected. The channel number of the channel currently disconnected is displayed in gray, for example, 03. If one or more channels of the current module are added to the scan list, this operation is invalid.

2 Close

Close the channel currently selected. Only one channel can be closed each time. The channel number of the channel currently closed is displayed in green, for example, 02. If one or more channels of the current module are added to the scan list, this operation is invalid.

3 Read

Read the measurement value of the current channel. This operation is only applicable to channels added to the scan list.

4 Card Reset

Initialize the status of each channel of the current module. If one or more channels of the current module are added to the scan list, this operation is invalid.

To Control MC3324

MC3324 is a mixed multiplexer with 20 voltage channels and 4 current channels. The 20 voltage channels (from channel 01 to channel 20) are divided into two banks of 10 two-wire channels each and can be used for 2-wire and 4-wire connections. When making 4-wire resistance measurement, the instrument automatically pairs channel n with channel $n+10$ (wherein, n is an integer between 1 and 10). 4 current channels (from channel 21 to channel 24) are used to measure DC current or AC current. MC3324 is used with the external terminal block (M3TB24) which has a built-in thermocouple reference junction.

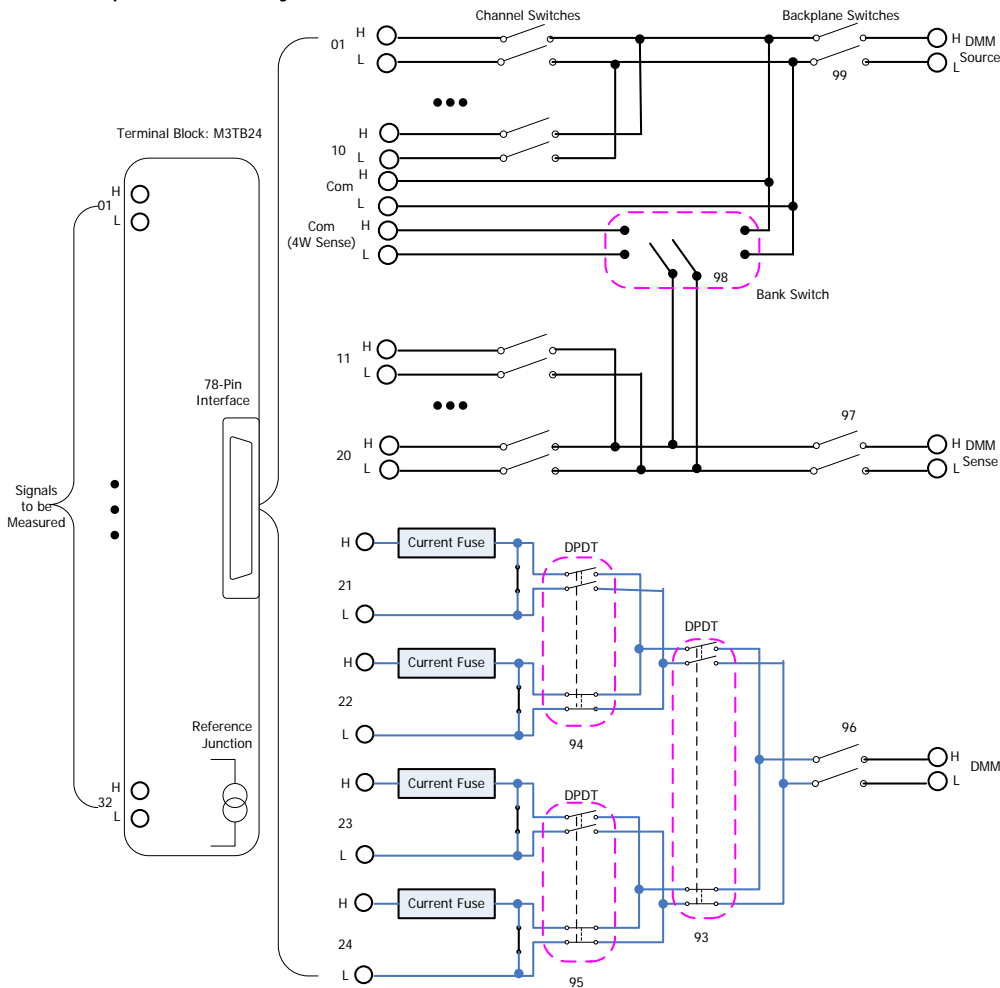

Figure 2-22 MC3324 Schematic Diagram

The control interface of MC3324 is as shown in Figure 2-23. Press **Page Up** and **Page Dn** at the front panel to open the previous and next pages of the control interface. Use the up/down and left/right direction keys to select the desired channel. The channel currently selected is highlighted, for example, **01**. You can perform

various operations on the channel currently selected (such as disconnect and close the channel).

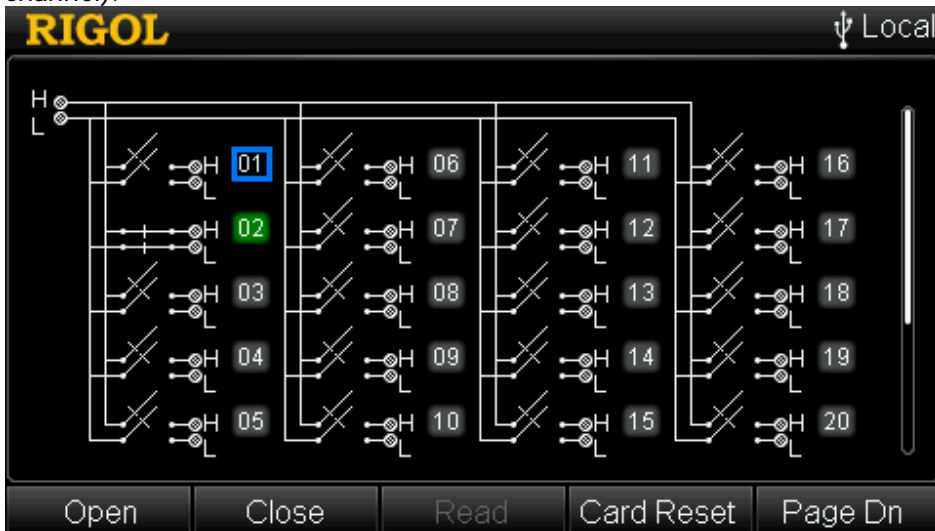

Figure 2-23 MC3324 Control Interface (Bank Joined)

If the channel currently selected is not added to the scan list and other channels of the module are not added to the scan list, pressing **OK** can close the channel. At this point, pressing **OK** again can open the channel. If the channel is added to the scan list, pressing **OK** can close the channel and read the measurement result (before closing this channel, the instrument opens the channel currently closed). Pressing **OK** again can read the measurement result again.

1 Open

Disconnect the channel currently selected. The channel number of the channel currently disconnected is displayed in gray, for example, 03. If one or more channels of the current module are added to the scan list, this operation is invalid.

2 Close

Close the channel currently selected. Only one channel can be closed each time. The channel number of the channel currently closed is displayed in green, for example, 02. If one or more channels of the current module are added to the scan list, this operation is invalid.

3 Read

Read the measurement value of the current channel. This operation is only applicable to channels added to the scan list.

4 Module Reset

Initialize the status of each channel of the current module. If one or more channels of the current module are added to the scan list, this operation is

invalid.

5 Bank Separate/Bank Joined

By default, the first 20 channels of this module are in “Bank Joined” state (namely the bank switch in Figure 2-22 is closed and the control interface is as shown in Figure 2-23). At this point, this module can only be used for 2-wire connection. Press **Page Dn** → **Bank Sepa** to execute the “Bank Separate” operation (namely disconnect the bank switch in Figure 2-22 and the control interface is as shown in Figure 2-24). At this point, this module is divided into two independent banks and can be used for 4-wire connection. When it is used for 4-wire resistance measurement, the instrument pairs channel n and channel n+10 automatically (wherein, n is an integer between 1 and 10). Channel n is used to connect the source terminal of DMM and channel n+10 is used to connect the sense terminal of DMM.

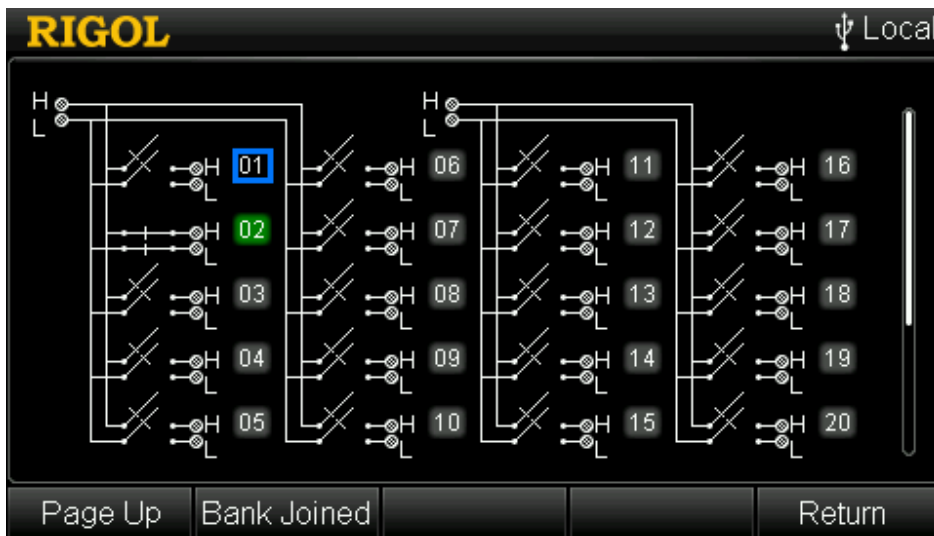

Figure 2-24 MC3324 Control Interface (Bank Separate)

1 Open

Disconnect the channel currently selected. The channel number of the channel currently disconnected is displayed in gray, for example, 03. Pressing **OK** can also open the channel currently selected.

2 Close

Close the channel currently selected. The channel number of the channel currently closed is displayed in green, for example, 02. Pressing **OK** can also close the channel currently selected.

3 Card Reset

Initialize the status of each channel of the current module.

To Control MC3534

MC3534 is a multifunction module (MFC for short). This module combines four 8-bit digital input/output (DIO) channels, four 32-bit totalizer (TOT) channels and four analog output (DAC) channels.

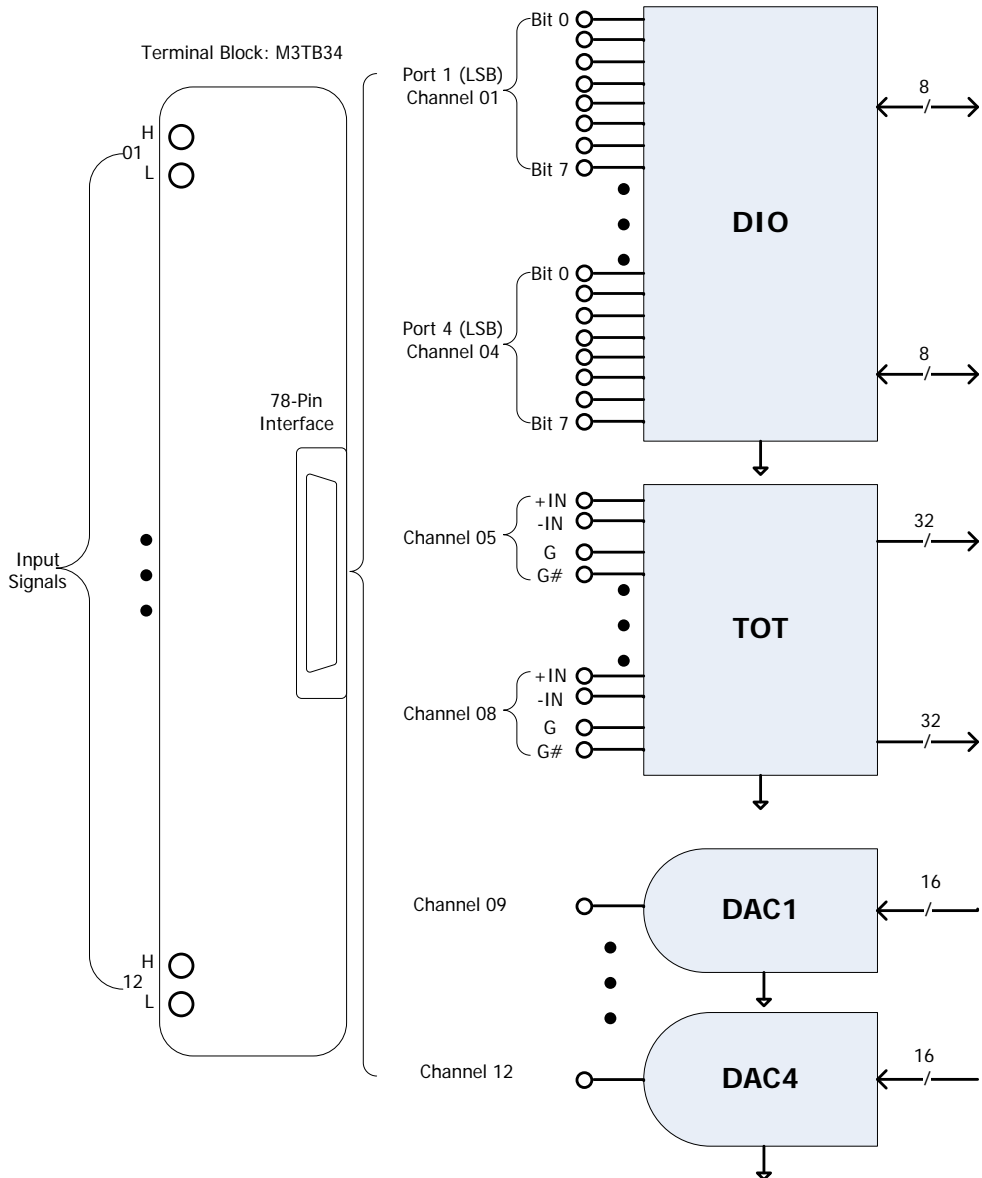

Figure 2-27 MC3534 Schematic Diagram

You can enter the channel configuration guide of the MFC module by pressing **Control**, selecting MC3534 and pressing **Config**. The channel number is S01 by default (wherein, S is the number of the module slot and the range is from 1 to 5)

and the function is fixed as DIO. For detailed information about the channel configuration, please refer to “**Channel Configuration**”. This section mainly introduces how to control MC3534.

The control interface of MC3534 is as shown in the figure below. Use the up/down and left/right direction keys to select the desired channel. The channel currently selected is highlighted, for example, 01. You can perform various operations on the channel currently selected (such as the write and read operations).

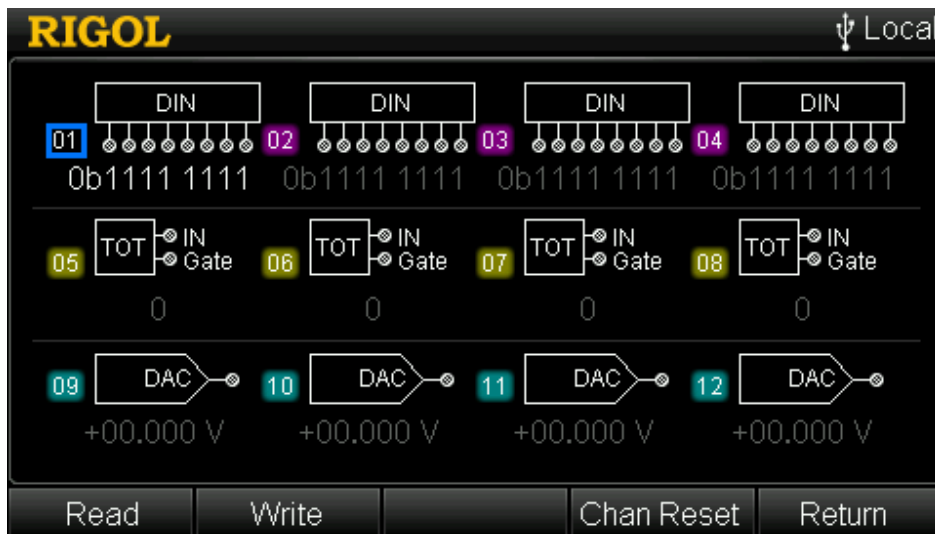

Figure 2-28 MC3534 Control Interface

1 DIO Channel Control

Digital Input (DIN): the four DIO channels can all be used as digital input ports. You can configure the DIO channels to the scan list to read the input value of the specified channel automatically or you can read the input value manually via the MC3534 control interface.

Digital Output (DOUT): only DIO channels that are not configured to the scan list can be used as digital output (DOUT) ports.

- Read: read the input value of the channel currently selected. The value is displayed on the interface.
- Write: edit the output value of the channel currently selected. Press **Write** and use the numeric keyboard to input the desired value between 00000000 and 11111111. If the channel currently selected is added to the scan list, this operation is invalid.

2 TOT Channel Control

You can configure the TOT channels to the scan list to read the count of the specified channel automatically or you can read the count manually via the

MC3534 control interface.

- Read: read the count of the channel currently selected. The count is displayed on the interface.
- Start: press this softkey and the current TOT channel starts counting.
- Stop: press this softkey and the current TOT channel stops counting. This function is only valid when the current channel is counting.
- Def Start: when the instrument starts next time (the power-on setting is "Last"), this TOT channel starts counting by default. You do not need to press **Start**.
- Def Stop: when the instrument starts next time (the power-on setting is "Last"), this TOT channel stops counting by default. You need to press **Start** to start the counting.

3 DAC Channel Control

The multifunction module (MC3534) provides 4 low-noise analog output (DAC) channels. The 4 analog output channels are capable of outputting calibrated voltages between -12 V and +12 V with 16 bits of resolution. Each DAC channel can be used as the programmable voltage source for other analog control device. The DAC channels are usually numbered "S09" to "S12"; wherein, S denotes the number of the slot of the multifunction module.

Press **Write** and use the numeric keyboard to input the desired output value between -12.000 V and +12.000 V and the resolution is 1 mV.

4 Channel Reset

Reset the status of the channel currently selected.

To Control MC3648

MC3648 is a 4×8 matrix switch and contains 32 two-wire crosspoints. Each crosspoint relay has its own unique channel label representing the row and column. For example, channel 24 represents the crosspoint connection between row 2 and column 4. This module does not connect to DMM. You can close multiple channels and connect multiple inputs to multiple outputs at the same time. Before making any connection, make sure that the connection will not introduce any danger.

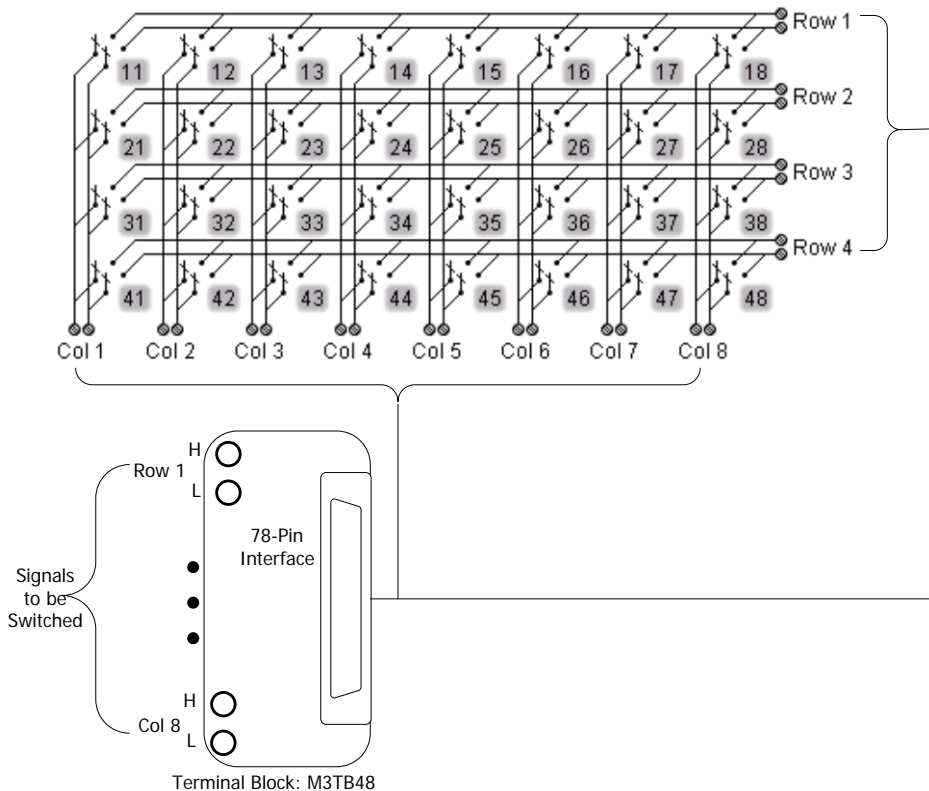

Figure 2-29 MC3648 Schematic Diagram

The control interface of MC3648 is as shown in Figure 2-30. Use the up/down and left/right direction keys to select the desired channel. The channel currently selected is highlighted. You can perform various operations on the channel currently selected (such as disconnect and close the channel).

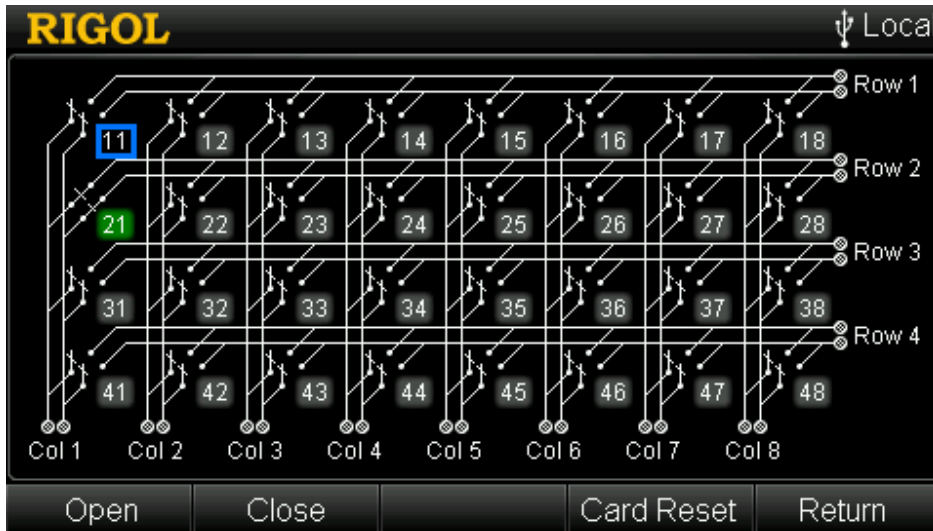

Figure 2-30 MC3648 Control Interface

1 Open

Disconnect the channel currently selected. The channel number of the channel currently disconnected is displayed in gray. Pressing **OK** can also open the channel currently selected.

2 Close

Close the channel currently selected. The channel number of the channel currently closed is displayed in green. Pressing **OK** can also close the channel currently selected.

3 Card Reset

Initialize the status of each channel of the current module.

Matrix Combination:

For M300, you can combine two or more (up to 5) matrixes together to form a larger matrix. For example, you can connect the rows or (columns) of two 4×8 matrixes to form a 4×16 (8×8) matrix.

Note: The combined matrix provides more complicated signal switch. You can connect more inputs to more outputs at the same time. Please make sure that the connection will not introduce any danger.

Alarm Channel Setting

M300 provides 4 alarm channels (Alarm1, Alarm2, Alarm3 and Alarm4). You can assign an alarm channel to a configured channel via the channel configuration guide. An alarm will be generated from the corresponding channel when a reading fulfills the specified alarm condition during a scan or monitor.

When an alarm is generated, the corresponding pin of the Alarm/Ext Trig interface at the rear panel (converted from the **[RS-232/Alarms/Ext Trig]** interface) outputs a pulse with specified edge. If an alarm channel is assigned to multiple channels, the corresponding pin outputs a pulse when any of the channel generates an alarm.

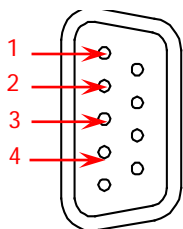

Pin	Definition
1	Alarm 1 Output
2	Alarm 2 Output
3	Alarm 3 Output
4	Alarm 4 Output

Alarm/Ext Trig Interface

Press , , or at the front panel to set the output mode of the corresponding pin of the Alarm/Ext Trig interface for the 4 alarm channels when an alarm is generated.

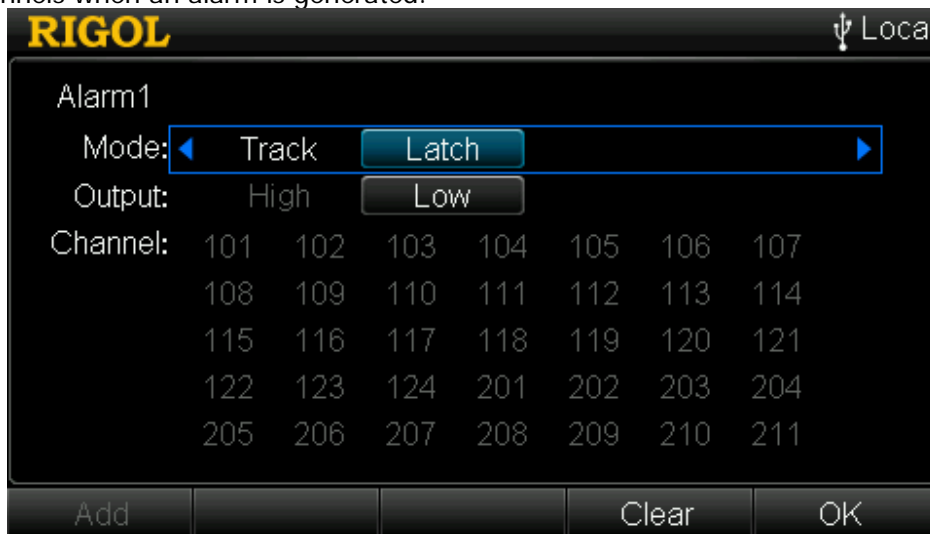

Figure 2-31 Alarm Channel Setting Interface

1 Mode

Set the output mode of the corresponding pin when an alarm is generated. Use the up/down direction key to select **Mode** and use the left/right direction key to select "Latch" or "Track".

- **Latch**

In this mode, the corresponding pin is latched to the status (high level or low level) specified in **Output** when the alarm channel generates an alarm until you clear it by initiating a new scan or cycling power. You can also manually clear (pressing **Clear**) the output of this pin at any time (even during a scan) and the alarm data is not cleared. The alarm data is cleared when you initiate a new scan.

- **Track**

In this mode, the corresponding pin jumps to the status (high level or low level) specified in **Output** when a reading of the channel crosses a limit and remains outside the limit. When a reading returns to within the limits, the output of this pin is cleared automatically. You can also manually clear (pressing **Clear**) this pin at any time (even during a scan) and the alarm data is not cleared. The output pin and alarm data are both cleared when you initiate a new scan.

2 Output

Set the output status of the corresponding pin when an alarm is generated. Use the up/down direction key to select **Output** and use the left/right direction key to select "High" or "Low".

- **Low**

When an alarm is generated, the corresponding pin outputs a TTL low level (0 V).

- **High**

When an alarm is generated, the corresponding pin outputs a TTL high level (+3.3 V).

3 Channel

Display the numbers of channels that select this alarm channel. By default, all the channels select Alarm1. You can modify the alarm configuration via the third step of the channel configuration guide (refer to "**Alarm Configuration**") or using **Add** and **Delete**.

- **Add**

Use the up/down direction key to select **Channel**, press **Add** and input the desired channel number. After that, the specified channel uses the current alarm channel and the number of the channel added is displayed in **Channel**.

- **Delete**

Use the up/down direction key to select **Channel**, use the left/right direction key to select the desired channel number and press **Delete** to delete the specified channel. The number of the channel deleted will not be displayed in **Channel**.

4 Clear

Press this softkey to clear the alarm output of the corresponding pin of the current alarm channel manually, but the alarm data is not cleared.

View Switch

M300 provides view switch function which provides multiple display forms for the scan list and scan results. Press  at the front panel to display the scan history information, channel status table, measurement curve and the channel information.

Scan History Information

Press  at the front panel to enter the scan history information interface through which you can view the start time, scan sweep, count, channel number and the corresponding function as well as the maximum, minimum, average and standard deviation measured. You can also store/read the measurement data and view the measurement value of the specified channel.

Note: When the count reaches to 100000, the new readings will overwrite the first readings stored.

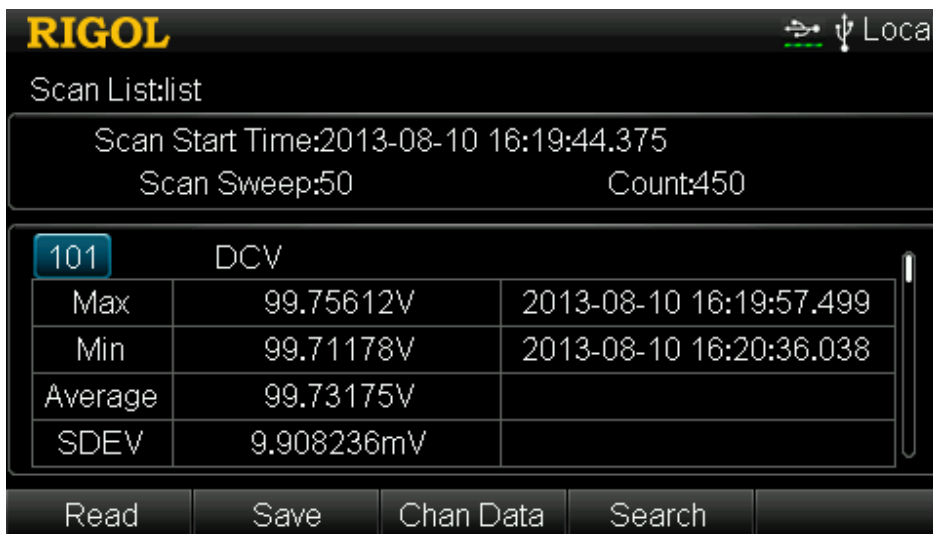

Figure 2-32 Scan History Information

1 Read

Read the measurement data stored in the internal or external memory. Press **Read** and the instrument enters the store and recall interface (the file type is set to "Meas Data" automatically). Please refer to "**Store and Recall**" to select the desired file to read.

2 Save

Save the measurement data into the internal or external memory. Press **Save** and the instrument enters the store and recall interface (the file type is set to

"Meas Data" automatically). Please refer to "**Store and Recall**" to save the data.

3 Channel Data

Select a channel and press **Chan Data** to view the measurement values of this channel. These values contain time stamps. Press **Search** and use the numeric keyboard to input the point number to quickly locate the data of the specified point. Press **Return** to return to the scan history information interface.

4 Search

Press **Search** and input the desired channel number to display the specified channel in the interface. When a larger number of channels are contained in the scan list, this softkey can be used to quickly locate the desired channel to view the channel information.

Channel Status Table

Press  at the front panel again to enter the channel status table interface as shown in Figure 2-33. In this interface, you can judge the channel status.

- Yellow: channels not added to the scan list is displayed in yellow
- Green: channels added to the scan list is displayed in green
- Red: during a scan, an alarm is generated, the corresponding channel is displayed in red

Note: This status table displays the channel status in real time. For example, the channel is displayed in red after an alarm is generated. If the next measurement value is judged as PASS, the channel will be displayed in green again.

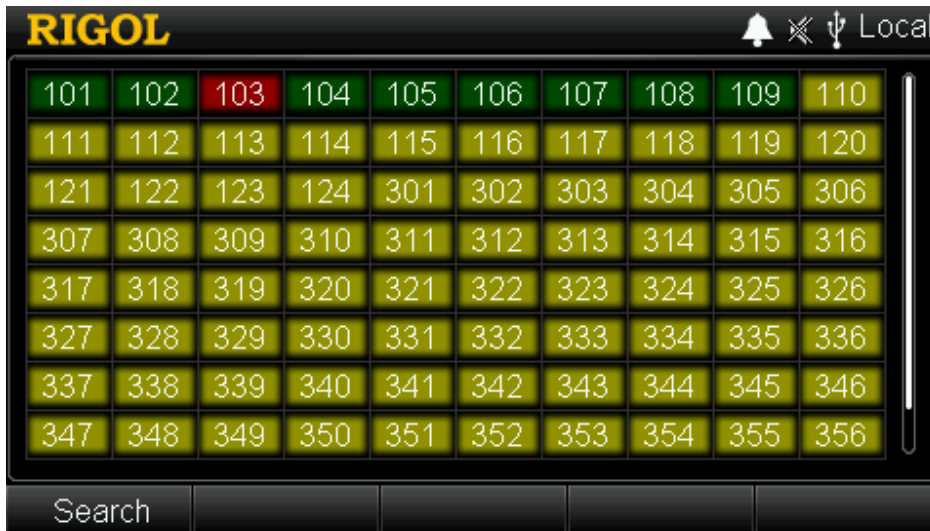

RIGOL										Local
101	102	103	104	105	106	107	108	109	110	
111	112	113	114	115	116	117	118	119	120	
121	122	123	124	301	302	303	304	305	306	
307	308	309	310	311	312	313	314	315	316	
317	318	319	320	321	322	323	324	325	326	
327	328	329	330	331	332	333	334	335	336	
337	338	339	340	341	342	343	344	345	346	
347	348	349	350	351	352	353	354	355	356	
Search										

Figure 2-33 Channel Status Table

Measurement Curve

Press  at the front panel again and the instrument enters an interface with a blank coordinate. This interface can display the measurement curves of the specified channels.

1 Switch

Press **Switch** to switch the cursor to select the channel number or the curve. By default, the channel number is selected. At this point, you can delete the channel selected or select other channel number by using the left/right direction key. Press **Switch** to switch the cursor to select the curve and use the left/right direction key to view the curve outside of the range of the horizontal axis.

2 Add

Press **Add** and use the numeric keyboard to input a channel number in the scan list. The instrument starts drawing the measurement curve in the coordinate. Up to 4 channels can be added.

3 Delete

To delete a channel, press **Switch** to switch the cursor to select the channel number and use the left/right direction key to select the channel number to be deleted, and then press **Delete**.

4 Zoom In

Press this softkey to reduce the maximum of the horizontal axis to zoom in the curve.

5 Zoom Out

Press this softkey to increase the maximum of the horizontal axis to zoom out the curve.

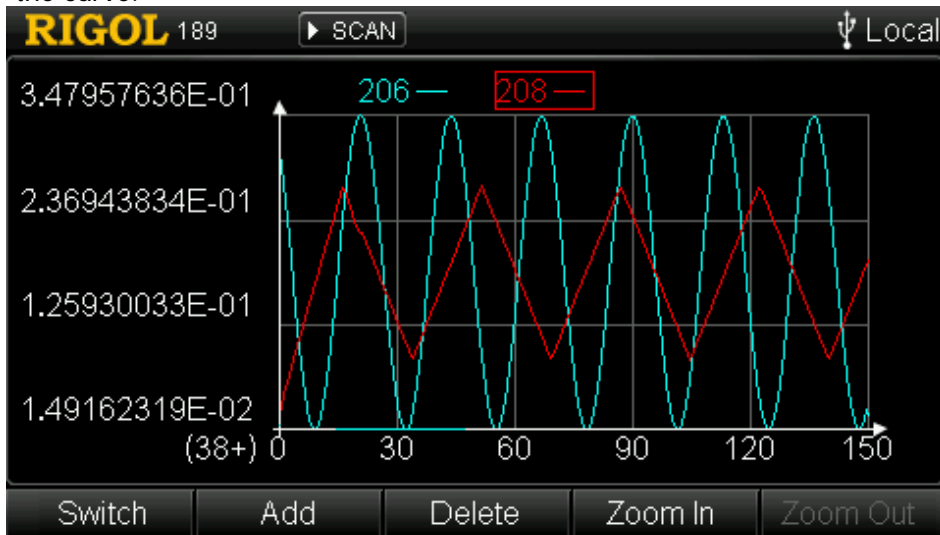



Figure 2-34 Measurement Curve

Channel Information

Press  at the front panel again and the instrument enters the channel information display interface.



Channel	Relay Cycle	Channel	Relay Cycle	Channel	Relay Cycle
101	181Cyc	102	170Cyc	103	167Cyc
104	75Cyc	105	75Cyc	106	50Cyc
107	50Cyc	108	50Cyc	109	59Cyc
110	9Cyc	111	11Cyc	112	9Cyc
113	9Cyc	114	8Cyc	115	9Cyc
116	8Cyc	117	9Cyc	118	8Cyc
119	9Cyc	120	9Cyc	121	240Cyc
122	237Cyc	123	233Cyc	124	232Cyc

Figure 2-35 Relay Cycle/Alarm Info/Error Info

1 Relay Cycle

M300 measures relay cycles and stores the result in the non-volatile memory of the corresponding module. When starting up and detecting the modules currently inserted, M300 reads the cycle of each relay. Via this interface, you can view the statistical results to ensure proper maintenance of the relay. For more information, please refer to the schematic diagrams of the modules in “**Module Control**”.

2 Alarm Information

Read and clear the first 100 alarm messages (generated on 4 alarm channels) of the last scan, including the alarm reading, the time, channel and mode of the alarm as well as the alarm channel.

3 Error Information

Read and clear the first 20 error messages in the error queue.

When remote command grammar error or hardware error is detected, the system displays “Error” in the user interface and stores the first 20 error messages in the error queue of the instrument. If error is still generated, the last error message in the error queue will be replaced by “Error queue overflow”. At this point, the instrument will not store the new error messages unless error messages in the error queue are removed. Turning off the instrument (or using the remote command *CLS) can clear the error queue.

Store and Recall

M300 allows you to save the system configuration, measurement configuration and measurement data into the internal or external memory and recall them when required. Press **Store/Recall** to enter the interface as shown in the figure below.

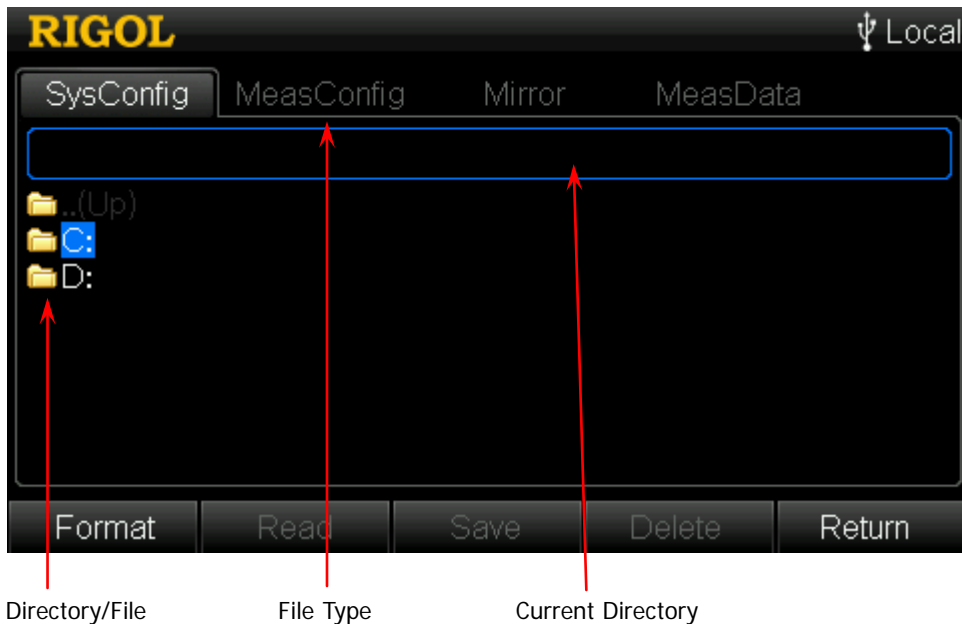

Figure 2-36 Store and Recall

1 File Type

Display the four file types of M300 storage and recall. You can select the desired file type using the left/right direction key.

2 Current Directory

Display the directory currently selected. In the interface displayed by default when **Store/Recall** is pressed, this area is empty.

To select the specified directory, please execute the following operation in the interface as shown in Figure 2-36.

- 1) Select the desired drive letter (**C:** or **D:**) using the up/down direction key and press **OK**; for example, **D:**.
- 2) Select the desired folder under this drive letter using the up/down direction key and press **OK**; for example, RIGOL.

At this point, the current directory area displays D:\RIGOL\.

3 Directory/File

Display the files and folders under the current directory. In the interface displayed by default when **Store/Recall** is pressed, this area displays the drive

letter (**C:** and/or **D:**). The **C:** disk is the local disk with 256 Mbytes storage space. The **D:** disk is the external USB storage device (it will only be displayed when an USB storage device is connected). Use the up/down direction key to select the desired file, folder or drive letter.

Menu Explanations:

1 Format

Press **Format** to delete all the data under the corresponding directory. This menu is only available when **C:** disk is currently selected.

2 Read

Press **Read** to read the file currently selected. This menu is valid only when the specified type of file is selected.

Note: Before reading a system configuration file, make sure that the module currently inserted and the module used when storing the configuration file is of the same type.

3 Save

Press **Save** to enter the filename input area. This menu is valid only when the current directory can store the specified type of file.

4 Delete

Press **Delete** to remove the file currently selected. This menu is only valid the specified type of file is selected.

File Type

You can store or read various types of files.

1 System Configuration

Store the current system configuration as a file with the suffix “.sfg” into the internal memory or external USB storage device.

The system configuration saves the states of all the modules, including all the system information (under **Utility** → **System**) except date and time and the configurations of the I/O interfaces (under **Utility** → **I/O**).

2 Measurement Configuration

Store the current measurement configuration as a file with the suffix “.mfg” into the internal memory or external USB storage device.

The measurement configuration saves the scan list settings (including trigger

count, trigger mode, interval for auto trigger mode and trigger edge type for external trigger) and the channel configurations (including measurement configuration, scaling configuration, alarm configuration and advanced configuration).

3 Mirror Configuration

Combine the "System Configuration" and "Measurement Configuration" files into one file (with the suffix ".mir") and store it in the internal memory or the external USB storage device. The mirror configuration is the combination of the system configuration and the measurement configuration.

4 Measurement Data

Store the current measurement data as a file with the suffix ".dat" or ".csv" into the internal memory or external USB storage device.

Note: The file with the suffix ".csv" can only be stored in the USB storage device.

Internal Storage

The internal **C:** disk holds 256 Mbytes storage space and can store four types of files, including system configuration, measurement configuration and measurement data (only ".dat" file).

Note: When executing internal storage for the first time, please format **C:** disk.

External Storage

The **D:** disk can store four types of files, including system configuration, measurement configuration, mirror configuration and measurement data (".dat" or ".csv" file), according to its capacity.

Before using the external storage, insert the USB storage device into the USB Host interface at the front panel. When the instrument detects the USB storage device,



will be displayed in the screen status bar.



CAUTION

When executing operations in the **D:** disk storage area, do not remove the USB storage device.

To Save a File

When the current directory can store the specified type of file, press **Save** to enter the filename input interface as shown in Figure 1-6. The length of the filename cannot exceed 12 characters. Please refer to the introduction in “**To Input Filename**” to input the filename and press **OK** to finish the save operation.

Utility

Press **Utility** at the front panel to enter the utility interface in which you can set the system parameters and I/O parameters, view the system information as well as update the system.



Figure 2-37 Utility

1 System

Press **System** to set the system parameters such as the date, time and language. For details, refer to “**System Setting**”.

2 I/O

Press **I/O** to configure the remote interfaces such as RS232 and LAN. For details, refer to “**I/O Configuration**”.

3 Information

Press **Info** to view the instrument serial number, software version, etc.

4 Detect

Press **Detect** to execute self-test or view the type, model, serial number and version of the module in each slot.

5 Update

Insert the USB storage device with the update file. After the instrument recognizes the USB storage device, press this softkey, the instrument read the update file and finish the update automatically. The update takes into effect after restarting the instrument. Note: Before updating the system, make sure the instrument power source is stable and the instrument is in non-operation state.

System Setting

Press **Utility** and the instrument enters the system configuration interface by default (or press **Utility** → **System**).

Date

Use the up/down direction key to select **Date** and use the numeric keyboard to set the system date. The format is as follows.

YYYY-MM-DD

Wherein,

YYYY denotes "Year" and the range is from 2001 to 2099;

MM denotes "Month" and the range is from 01 to 12;

DD denotes "Date" and the range is from 01 to 28, 29, 30 or 31 (related to the YYYY and MM currently set).

Time

Use the up/down direction key to select **Time** and use the numeric keyboard to set the system time. The format is as follows.

hh:mm:ss

Wherein,

hh denotes "Hour" and the range is from 00 to 23;

mm denotes "Minute" and the range is from 00 to 59;

ss denotes "Second" and the range is from 00 to 59.

Tip:

The date and time forms the system time. The instrument stores the measurement data and alarm data with the time stamp during a scan. In absolute trigger mode, the instrument triggers when the system time reaches the specified time.

Language

M300 supports Chinese and English menus and built-in help systems. All the messages and help information are displayed in the language selected. Use the up/down direction key to select **Language** and use the left/right direction key to select the desired language.

Sound

Use the up/down direction key to select **Sound** and use the left/right direction key to select "ON" or "OFF" to enable or disable the sound generated when operating any of the front panel keys. The current setting is stored in the no-volatile memory. When the sound is disabled,  is displayed in the status bar of the user interface.

DMM

Use the up/down direction key to select **DMM** and use the left/right direction key to select "ON" or "OFF" to enable or disable the DMM module (MC3065). When the DMM module is disabled, the system initializes the scan list automatically.

This operation is only valid when the DMM module is inserted. If the DMM module is not inserted, this option is fixed at "OFF" and cannot be modified.

Factory Settings

Use the up/down direction key to select **Factory** and the left/right direction key to select "ON" or "OFF" (the default is "OFF"). When "ON" is selected, the prompt message asking whether you want to restore all the settings to the factory setting will be displayed. Press **OK**. The factory settings are as shown in Table 2-5.

Table 2-5 Factory Settings

Parameter	Factory Setting
Scan Configuration	
Scan List	Empty
Reading Memory	Cleared
Max, Min, Average and SDEV	Cleared
Trigger Mode	Auto
Scan Interval	10 s (use TRIGger:SOURce TIMER)
Number of Scans	1
Measurement Configuration	
Function	DCV
Range	Auto
Integration Time	1 PLC
Input Impedance	10 M Ω
Channel Delay	Auto
TOT Read Mode	READ
TOT Trigger Mode	Rising

Scaling Configuration	
Scaling Configuration	OFF
A	0
B	1
C	0
x1	0
Unit	V
Alarm Configuration	
Alarm Mode	NONE
Alarm Channel	Alarm1
HI	0
LO	0
Alarm Channel Configuration	
Alarm Queue	Not cleared
Output Status	Cleared
Output Mode	Latch
Alarm Output	Low Level
Channel Monitor	
Monitor in Progress	Stop
Module Control	
MC3120/MC3132/MC3164	All channels off
MC3416	All channels off
MC3534	4 DIO ports: input 4 TOT counts: 0 4 DAC: 0 VDC
MC3648	All channels off
System Related	
Date	No change
Time	No change
Language	No change
Sound	ON
DMM	No change
Screen Saver	OFF
Decimal Point	.
Separator	None
Power-on	Default

Power Key	OFF
Module Plug	No change
Brightness	8
Error Queue	Not cleared

Power-on Settings

Use the up/down direction key to select **Power-on** and use the left/right direction key to select "Default" or "Last" (the configuration before the last power-off) as the initial status at power-on. If "Default" is selected, the system will be restored to its factory settings when starting up next time. The following settings always recall the configuration before the last power-off and will not be affected by "Default".

- Power Switch
- Language
- Module Plug
- I/O Configuration

Power-off Status

Use the up/down direction key to select **Power-off** and use the left/right direction key to select "ON" or "OFF" (the default is "OFF"). When "ON" is selected, the prompt message asking whether you want to restore all the settings to the status before the last power-off will be displayed. Press **OK**.

Preset Settings

Use the up/down direction key to select **Preset** and use the left/right direction key to select "ON" or "OFF" (the default is "OFF"). When "ON" is selected, the prompt message asking whether you want to restore all the settings to the preset status will be displayed. Press **OK**. The preset settings are as shown in the table below.

Table 2-6 Preset Settings

Parameter	Factory Setting
Scan Configuration	
Scan List	No change
Reading Memory	Cleared
Max, Min, Average and SDEV	Cleared
Trigger Mode	No change
Scan Interval	No change
Number of Scans	No change

Measurement Configuration	
Function	No change
Range	No change
Integration Time	No change
Input Impedance	No change
Channel Delay	No change
TOT Read Mode	No change
TOT Trigger Mode	No change
Scaling Configuration	
Scaling Configuration	No change
A	No change
B	No change
C	No change
x1	No change
Unit	No change
Alarm Configuration	
Alarm Mode	NONE
Alarm Channel	Alarm1
HI	0
LO	0
Alarm Channel Configuration	
Alarm Queue	No change
Output Status	No change
Output Mode	No change
Alarm Output	No change
Channel Monitor	
Monitor in Progress	Stop
Module Control	
MC3120/MC3132/MC3164	All channels off
MC3416	All channels off
MC3534	4 DIO ports: input 4 TOT counts: 0 4 DAC: 0 VDC
MC3648	All channels off
System Related	
Date	No change

Time	No change
Language	No change
Sound	ON
DMM	No change
Screen Saver	OFF
Decimal Point	.
Separator	None
Power-on	Default
Power Key	OFF
Module Plug	No change
Brightness	8
Error Queue	Not cleared

Screen Saver

Use the up/down direction key to select **Saver** and use the left/right direction key to select "OFF" or set the time to wait before entering the screen saver state.

- OFF: disable the screen saver function.
- Time: you can use the numeric keyboard to set a value between 1 and 60. The unit is minute and the resolution is 1 minute. The instrument enters the screen saver state automatically when the instrument has not been operated for the specified period of time.

Decimal

Use the up/down direction key to select **Decimal** and use the left/right direction key to set the display form of the decimal point of the screen data to "." or ",".

Separator

Use the up/down direction key to select **Separator** and use the left/right direction key to set the display form of the separator of the screen data to “,” (or “.”), “None” or “Space”.

Tip:

The display form of the decimal point affects the display form of the separator. The two cannot be set to “.” or “,” at the same time. There are 6 kinds of data formats.

Decimal Point	Separator	Example
.	,	10.000,00
.	Space	10.000 00
.	None	10.00000
,	.	10,000.00
,	Space	10,000 00
,	None	10,00000

Power Switch

Use the up/down direction key to select **PwrSW** and use the left/right direction key to select “ON” or “OFF” to set whether the front panel power key is valid. The default is “OFF”.

- ON: the front panel power key is valid. After power-on, you need to press the front panel power key to start the instrument.
- OFF: the front panel power key is invalid. After power-on, the instrument starts automatically. But, you can still use the front panel power-key to turn off the instrument.

Module Plug

None of the current M300 modules are hot-swappable. To avoid damage, you can select the mainframe response below. Use the up/down direction key to select **Card Plug** and use the left/right direction key to select the way in which the instrument responds to the hot plug^[1] of the module.

- Restart: the instrument restarts automatically. If you insert the module during a scan, the instrument restarts and resumes the scan.
- Confirm: a prompt message is displayed. At this point, users need to confirm the module connection.
- Ignore: the instrument does not execute any operation and automatically recognize the module. Usually, the system works more efficiently when "Ignore" is selected.



CAUTION

In any situation, hot plug might result in instability as well as product damage or data loss.

Note^[1]: Hot plug/hot swap is defined as inserting or removing the module without turning off the instrument.

Analog Output

Select **Analog Output** using the up/down direction key and select "OFF" or "ON" using the left/right direction key to open or close the analog switch on the back board inside the M300 main frame.

The analog switch on the back board inside the M300 main frame is used to control the connection between the multiplexer module and DMM module. When the switch is open ("OFF" is selected), the multiplexer module and DMM module is not connected; at this point, M300 cannot measure the signal input from the multiplexer channel correctly. To acquire correct measurement, close the switch (select "ON").

Brightness

Use the up/down direction key to select **Bright** and use the left/right key to adjust the brightness between 0 and 15 (the default is 8). The current setting is stored in non-volatile memory.

I/O Configuration

M300 supports RS232, GPIB, LAN and USB interfaces. After configuring proper parameters for the above interfaces, you can control M300 remotely. Press **Utility** → **I/O** to enter the interface configuration interface.

To Set GPIB Address

Connect the instrument with the PC with GPIB card installed using GPIB cable before using the GPIB (General Purpose Interface Bus) Interface.

Each device on the GPIB interface must have a unique address. Press **Utility** → **I/O** → **GPIB** to enter the interface. Use the numeric keyboard to set the GPIB address to any integer between 0 and 30 and the default is "7". The address set is stored in the non-volatile memory.

To Set USB Parameters

A USB Device interface and a USB Host interface are provided by M300. The former is used to connect computer to realize remote control and the latter is used to connect an USB storage device to store measurement data, information in screen and etc.

Before using the USB Device interface, please use the USB cable connect the USB Device interface at the rear panel of M300 and the USB Host interface of the computer and press **Utility** → **I/O** → **USB** to enter the USB Device setting interface in which USB ID is displayed. At this point, you can control M300 remotely via USB Device interface.

Press **Utility** → **I/O** → **USB** → **Host** to enter the USB Host setting interface.

- **Log Data**

When "Auto" is selected, the instrument configuration and scan data will be stored as .csv files in the USB storage device during a scan.

The path of the files stored is usually <the drive letter of the USB storage device>:\M300\data\<<the series number of M300>\<the start time of the scan>, for example, G:\M300\data\M300123123123\20131121_140506.

The instrument configuration file is usually config.csv and the scan data file is usually dat00001.csv. If "64K" row limit is selected in this scan, the files (such as dat00002.csv and etc.) may be created.

When "OFF" is selected, the scan data will be stored into the internal memory.

Note: When auto storage of data into the USB storage device is selected, the measurement speed of the instrument might be affected.

- **Export Data**

Set whether the scan data stored in the internal memory will be exported to the USB storage device when a scan finishes.

- **Row Limit**

If "64K" is selected, the file stored in the USB storage device cannot exceed 64K rows. Each time when the data in the scan data file exceeds 64k rows, a new .csv file will be created automatically by the instrument to store the following data.

- **File Separator**

Select ";", "Tab" or "," as the separator of the scan data file stored in the USB storage device.

- **Import**

If "Yes" is selected when a USB storage device is inserted, the instrument searches and lists the .blcfg files in the root directory of the USB storage device. Select the desired file and press the **Import** softkey to import it. .blcfg file stores the measurement configuration. After it is imported, the scan list settings (including trigger count, trigger mode, interval for auto trigger mode and trigger edge type for external trigger) and the channel configurations (including measurement configuration, scaling configuration, alarm configuration and advanced configuration) are overwritten.

To Set RS232 Parameters

You can convert the **[RS-232/Alarms/Ext Trig]** interface at the rear panel to two 9-pin interfaces using the Mixed Interface Convert Cable (accessory). Wherein, one is a 9-pin male interface used as a standard RS232 interface (the definitions of the pins are as shown in the table below). The 9-pin female interface is used for alarm output, external trigger signal input, etc.

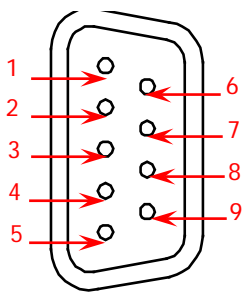

RS232 Interface

Pin	Name	Definition
1	DCD	Data Carrier Detect
2	RXD	Received Data
3	TXD	Transmitted Data
4	DTR	Data Terminal Ready
5	SGND	Signal Ground
6	DSR	Data Set Ready
7	RTS	Request To Send
8	CTS	Clear To Send
9	RI	Ring Indicator

Connect the RS232 interface with the PC or data terminal equipment (DTE) device using a RS232 cable and set the interface parameters (such as the baud rate and

parity) to match the PC or terminal device. At this point, you can control the instrument remotely. The measurement result of the instrument can be output to serial port receiving devices via this interface.

Press **Utility** → **I/O** → **RS232** to enter the interface.

1 Print

Use the up/down direction key to select **Print** and use the left/right direction key to select "ON" or "OFF" to enable or disable the measurement data output function of the serial port. After connecting the instrument and the computer via RS232 and enable the print function, the instrument will output the measurement readings automatically through RS232 interface when the instrument is measuring. At this point, you can capture the readings using serial port data acquisition tool.

2 Parity

Use the up/down direction key to select **Parity** and use the left/right direction key to set the parity to "None" (8 data bits), "Odd" (7 data bits) or "Even" (7 data bits). Please select a parity that matches the PC or DTE. When you set the parity, you are also indirectly setting the number of data bits. The current setting is stored in the non-volatile memory.

3 Flow Control

Use the up/down direction key to select **Flow** and use the left/right direction key to select "NONE", "XON/XOFF", "DTR/DSR", "RTS/CTS" or "MODEM". Please select a flow control mode that matches the PC or DTE.

- **NONE**

In this mode, data is sent and received over the RS232 interface without any flow control used. When this mode is selected, please select relatively slower baud rate (lower than 9600 Baud) and please do not send data that is too long (longer than 128 characters) and does not contain end bit.

- **XON/XOFF**

This mode is software flow control mode. This mode uses special characters embedded in the data stream to control the flow. If the instrument is addressed to send data, it continues sending data until the "XOFF" character (13H) is received. When the "XON" character (11H) is received, the instrument resumes sending data.

- **DTR/DSR**

This mode is hardware flow control mode. The instrument monitors the state of the DSR pin. When the state goes "True", the instrument sends data over the interface. When the state goes "False", the instrument stops sending data. The instrument sets the DTR pin "False" when the input buffer is almost full (approximately 100 characters) and sets the pin "True"

when space is available again.

- **RTS/CTS**

This mode is hardware flow control mode and it operates the same as the DTR/DSR mode. The instrument monitors the state of the CTS pin. When the state goes "True", the instrument sends data over the interface. When the state goes "False", the instrument stops sending data. The instrument sets the RTS pin "False" when the input buffer is almost full (approximately 100 characters) and sets the pin "True" when space is available again.

- **MODEM**

This mode uses the DTR/DSR and RTS/CTS pins to control the flow of data between the instrument and a modem. When the RS232 interface is selected, the instrument sets the DTR pin "True". The DSR pin is set "True" when the modem is on-line. The modem sets the CTS pin "True" when it is ready to receive data. The instrument sets the RTS pin "True" when it is ready to receive data. The instrument sets the RTS pin "False" when the input buffer is almost full (approximately 100 characters) and set the RTS pin "True" when space is available again.

4 **Baud Rate**

Use the up/down direction key to select **Baud** and use the left/right direction key to select the desired value (4800, 9600, 19200, 38400, 57600 and 115200). The unit is Baud. Please select a baud rate that matches the PC or DTE. The current setting is stored in the non-volatile memory.

To Set LAN Parameters

Connect the instrument to the PC or the network of the PC using network cable before using the LAN interface. Press **Utility** → **I/O** → **LAN** to enter the interface.

1 **Status**

Display the current LAN Status. Use the up/down direction key to view other information about network connection as shown in the figure below.

- Connected
- Disconnected
- LAN Configure...
- IP Conflict

2 **IP Mode**

The IP address configuration mode can be DHCP, AutoIP or ManualIP. By default, DHCP is enabled, AutoIP and ManualIP are disabled. In different IP configuration mode, the configuration mode of network parameters (such as the IP address) is different.

Tip

- When all the three IP configuration modes are enabled, the priority of the parameter configuration from high to low is "DHCP", "AutoIP" and "ManualIP".
- The three IP configuration modes cannot be all disabled at the same time.

1) DHCP (Dynamic Host Configuration Protocol)

In this mode, the DHCP server of the current network distributes network parameters (such as the IP address) to the instrument.

Use the up/down direction key to select **DHCP** and use the left/right direction key to enable or disable the DHCP configuration mode. By default, DHCP is enabled.

2) AutoIP

In this mode, the instrument acquires an IP address from 169.254.0.1 to 169.254.255.254 and subnet mask 255.255.0.0 according to the current network configuration.

Use the up/down direction key to select **AutoIP** and use the left/right direction key to enable or disable the AutoIP configuration mode. By default, AutoIP is disabled.

Note: To acquire an IP address using this mode, you need to disable the DHCP mode. If DHCP is not disabled, the instrument will use the DHCP mode automatically.

3) ManualIP

In this mode, users define the network parameters of the instrument, including the IP address, subnet mask, default gateway and DNS (Domain Name Service).

Use the up/down direction key to select **ManualIP** and use the left/right direction key to enable the ManualIP configuration mode. By default, ManualIP is disabled. At this point, you need to use the up/down direction key to select **IP Addr**, **SubMask**, **Gateway** and **DNS** respectively and use the numeric keyboard to input the correct values.

Note: To use this mode to set the IP address, you need to disable the DHCP and AutoIP modes. Otherwise, the instrument will use the DHCP or AutoIP mode automatically.

- **IP Address**

The format of IP address is nnn.nnn.nnn.nnn, for example, 172.16.2.13. After enabling the ManualIP mode, use the up/down direction key to select **IP Addr** and use the numeric keyboard to set the desired IP

address.

- **Subnet Mask**

The format of subnet mask is nnn.nnn.nnn.nnn, for example, 255.255.255.0. After enabling the ManualIP mode, use the up/down direction key to select **SubMask** and use the numeric keyboard to set the desired subnet mask.

- **Gateway**

The format of gateway is nnn.nnn.nnn.nnn, for example, 172.16.2.1. After enabling the ManualIP mode, use the up/down direction key to select **Gateway** and use the numeric keyboard to set the desired gateway.

- **DNS**

The format of DNS address is nnn.nnn.nnn.nnn, for example, 202.96.199.133. After enabling the ManualIP mode, use the up/down direction key to select **DNS** and use the numeric keyboard to set the desired DNS address. Generally, users do not need to set the DNS address of the network and this parameter setting can be ignored.

3 VISAAddr

VISA (Virtual Instrument Software Architecture) is an advanced application programming interface developed by NI (National Instruments) for communication with various instrument buses using the same method regardless of the type of the instrument interface (GPIB, USB, LAN/Ethernet or RS232). The instrument communicating with it via the GPIB, USB, LAN/Ethernet or RS232 interface is called "Resource". The VISA address (also called VISA descriptor) refers to the resource name and describes the accurate name and position of the VISA resource. For example, if LAN interface is currently used for communicating with the instrument, the VISA descriptor is :TCPIP0::172.16.2.13::INSTR.

4 MAC

The physical address (also called MAC (Media Access Control) address or hardware address) is used to define the position of the network device. For an instrument, the MAC address is unique. When distributing an IP address for the instrument, the MAC address is always used to distinguish the instrument. The MAC address (48 bits, namely 6 bytes) is usually denoted by a six-section hexadecimal number, for example, 00-14-0E-42-12-CF.

5 Default

In the LAN parameter setting interface, press **Default** to restore the network parameters to their defaults.

6 Apply

In the LAN parameter setting interface, press **Apply** to configure the network parameters using the current settings.

System Information

Press **Utility** → **Info** to view the system information of the instrument, such as the model, serial number, hardware version and software version.

Detect

Press **Utility** → **Detect** to enter the interface as shown in the figure below. The 5 column diagrams represent the 5 slots. The corresponding slot number (such as Slot1) and the model of the module inserted into the slot are displayed below and above the column diagram respectively and the name of the module is displayed in the middle of the column diagram. Use the left/right direction key to select the desired module (slot without module and slot with the DMM module cannot be selected) and the module currently selected is displayed in blue.

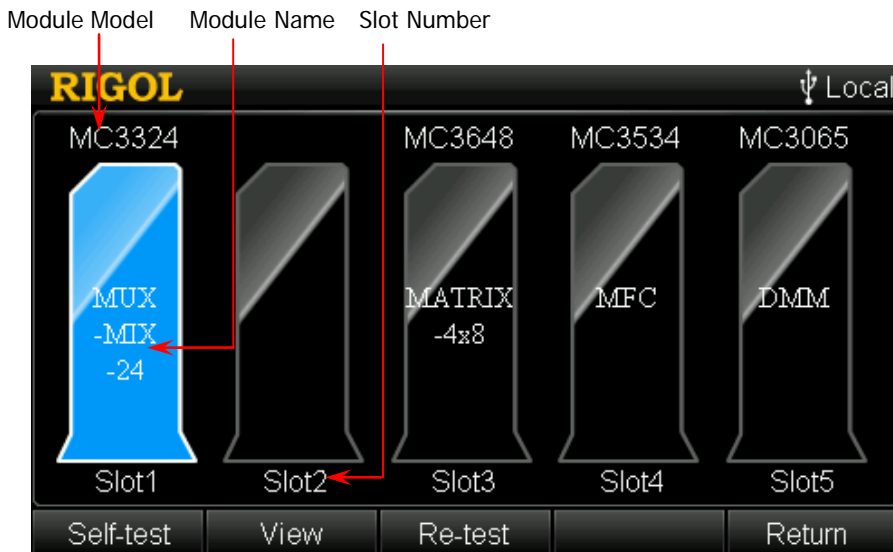

Figure 2-38 Detect Interface

1 Self-test

Select the corresponding slot and press this softkey to test the module.

2 View

Press this softkey to view the information of the module currently selected, including the function, model, serial number and version.

3 Re-test

If the module is inserted or removed when the instrument is running, select the corresponding slot and press this softkey to test the module of this slot again to acquire the latest status.

System Update

M300 can update the system by reading the update file stored in the USB storage device. Insert the USB storage device with the update file. After the instrument recognizes the USB storage device, press **Utility** → **Update**. Now, you can operate the instrument according to the prompts. The instrument will read the update file and finishes the update automatically. The update will take effect after you restart the instrument.



CAUTION

Please update the system advised by the technical support of **RIGOL** and make sure the power supply of the instrument is stable and the instrument is in non-operation state.

Chapter 3 To Use External DMM

You can connect the M300 with an external DMM and configure them in proper way to realize scan and measurement if the DMM module (MC3065) is not ordered. Any digital multimeter can be connected to the M300. This chapter takes RIGOL DM3068 as an example to illustrate the connection and configuration method.

Topics in this chapter:

- To Connect Instruments
- To Configure the Instruments
- Scan Control Method

To Connect Instruments

- 1 **Make sure that the DMM module is not installed in the M300 or not enabled**
- 2 **Split the mixed interface of M300**
Convert the **[RS232/Alarm/Ext Trig]** interface of M300 into two 9-pin interfaces (RS232 and Alarm/Ext Trig) using the Mixed Interface Convert Cable (accessory).
- 3 **Connect the M300 and DM3068**
 - (1) Connect the pin 5 and pin 7 of the Alarm/Ext Trig interface to the external trigger signal input interface (**[Ext Trig IN]**) of DM3068.
 - (2) Connect the pin 6 and pin 7 of the Alarm/Ext Trig interface to the VMC output interface (**[VM Complete OUT]**) of DM3068.

Note: This step is a typical connection which uses the VMC signal output from DM3068 as the advanced source signal. At this point, the trigger mode of M300 cannot be "External" and the advanced source type of M300 should be set to "External" and the edge type must be set to "Falling".

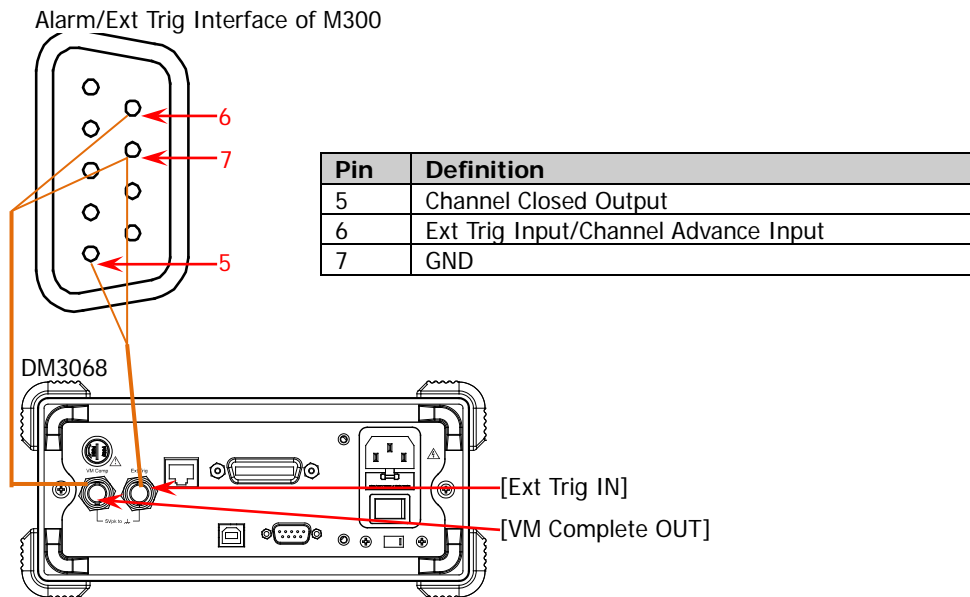

Figure 3-1 To Connect External DMM Schematic Diagram

- 4 **Connect the signals to be measured**
To connect the signals to be measured to the modules (multiplexer or multifunction module) through the external terminal blocks according to "Measurement Connections".

5 Connect the signals to be measured into the external DMM

Connect the analog bus interface at the rear panel of M300 and the measurement signal input terminal at the front panel of the external DMM using the analog bus external port (option, as shown in the figure below).

Note: When connecting the external DMM, the 5 terminals of the analog bus external port should be connected to the measurement signal input terminals of the external DMM according to the corresponding relations (as shown in the table below) between the numbers of the colored rings on the analog bus external port terminals and the measurement signal input terminals of the external DMM.

No.	Corresponding Input Terminal
6	HI
2	LO
7	HI SENSE
3	LO SENSE
1	CURRENT

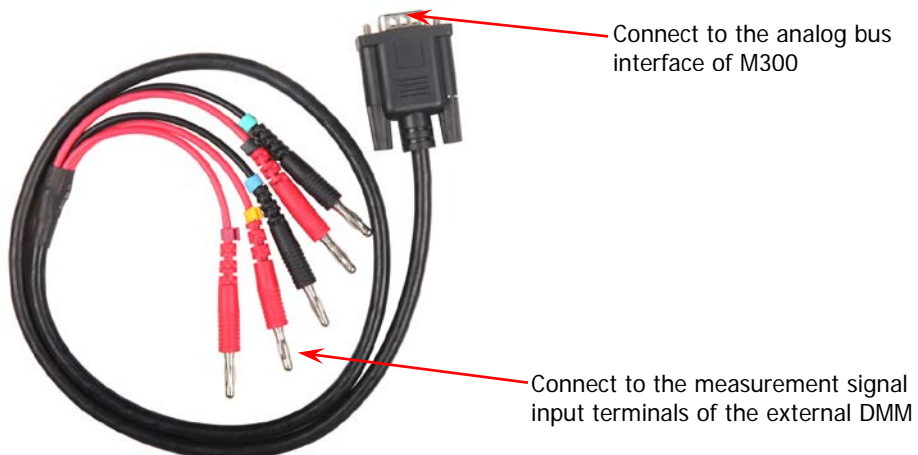

If only a single multiplexer module is used, you can connect the corresponding terminals (as shown in the figure below) on the external terminal block to the measurement signal input terminal of the external DMM.



M3TB20/M3TB32



M3TB64



M3TB24

To Configure the Instruments

1 To configure the external DMM

Set the external DMM to external trigger mode and triggering at the falling edge of the external trigger signal.

2 To configure the M300

(1) To configure the scan list parameters

Press **Config** to set the scan cycles, trigger mode, advanced source type, etc.

Based on the connection in Figure 3-1, external trigger mode cannot be selected, advanced source should be set to "external" and the edge type must be set to "Falling".

Note:

- External trigger mode and external advanced source cannot be selected at the same time.
- Manual trigger mode and "Single" advanced source cannot be selected at the same time.

(2) To configure channels to the scan list

Press **Config** → **Edit** → **New** to enter into the channel configuration guide. You can select desired channel number and set its scan mode and then press **Next** to enter into the advanced setting interface in which you can set the channel delay time.

- SCAN: 2-wire connection mode which is supported by all the multiplexer channels.
- SCAN_4W: 4-wire connection mode which is supported by the first 16 channels of MC3132 and the first 10 channels of MC3120 and MC3324.

Configure other channels into the scan list using the same method.

Scan Control Method



The typical scan control method based on the connection shown in Figure 3-1 is as follows.

- 1 After the external DMM and M300 are connected and configured properly, press the **Run/Stop** key at the front panel of M300 to place M300 into “wait for trigger” state.
- 2 When the preset trigger condition of the scan list is reached, the first channel in the scan list is closed. At this point, the pin 5 (Channel Closed Output) of the Alarm/Ext Trig interface outputs a negative TTL pulse (its pulse width is about $7\mu\text{s}$ and its output speed is related to the measurement speed and cannot exceed 1000 times per second) to the external trigger input interface and then the external DMM starts measuring.
- 3 When the measurement is finished, the VMC (Voltage Measurement Complete) output interface of the external DMM outputs a negative TTL pulse with about $2\mu\text{s}$ pulse width to the pin 6 (Channel Advance Input) of the Alarm/Ext Trig interface. Thus, M300 open the first channel and close the next channel. At this point, the pin 5 of the Alarm/Ext Trig interface outputs pulse again to control the external DMM to start measuring.

Then running down accordingly, all channels in the scan list are scanned.

Chapter 4 Remote Control

This chapter introduces the method to control M300 remotely. You can build communication between M300 and computer via GPIB, USB, RS232 or LAN to realize remote control based on the SCPI (Standard Commands for Programmable Instruments) commands. There are two remote control methods, including user-defined programming and sending command using PC software.

Note: When the instrument is working in remote mode, Rmt is displayed in the status bar in the user interface and the keys except **Monitor**,  and  at the front panel are locked. At this point, you can press  to exit the remote mode.

Topics in this chapter:

- User-defined Programming
- To Use PC Software

User-defined Programming

Users can select desired programming tool (such as LabVIEW, Matlab, Visual C++, etc.), program and control M300 by using SCPI commands on the basis of NI-VISA (National Instrument–Virtual Instrument Software Architecture).

1 Install NI-VISA Library

You need to install the VISA library of NI (download from <http://www.ni.com/visa/>) on your PC. NI-VISA is an application program interface developed by NI according to the VISA standards. You can use NI-VISA to realize the communication between the generator and PC through instrument buses (such as USB). VISA defines a set of software commands with which users can control the instrument without the need to understand how the interface bus works. For details, please refer to NI-VISA Help.

2 Build Communication between Instrument and PC

You need to build the communication between the generator and PC.

- **Using GPIB Interface:**

Connect M300 with the PC with GPIB card installed using GPIB cable before using the GPIB (General Purpose Interface Bus) Interface and set proper parameters according to **“To Set GPIB Address”**.

- **Using USB Interface:**

Use USB cable to connect M300 and PC. At this point, the hardware update wizard dialog box is displayed. Then, follow the instructions to install the “USB Test and Measurement Device (IVI)”. The steps are as following:

- 1) Select “Install the software automatically (Recommended)” and click “Next”;
- 2) Select “Don’t search. I will choose the driver to install” and click “Next”;
- 3) Select “USB Test and Measurement Device” and click “Next”;
- 4) When the installation is finished, click “Finish”.

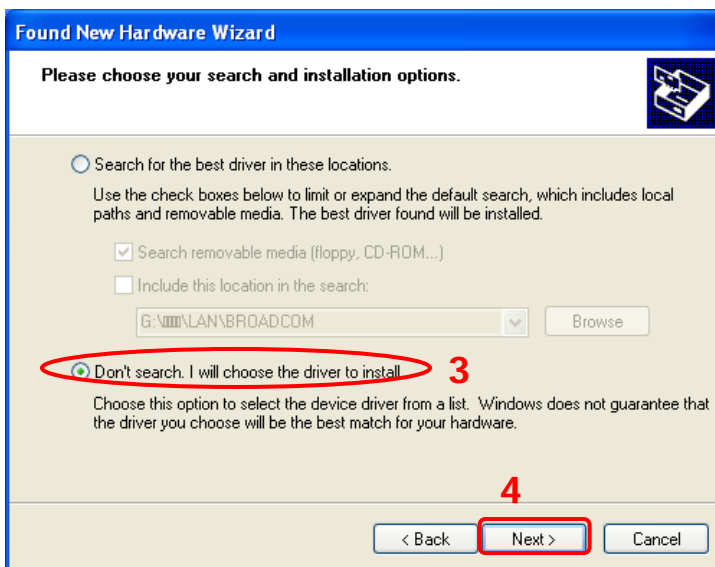
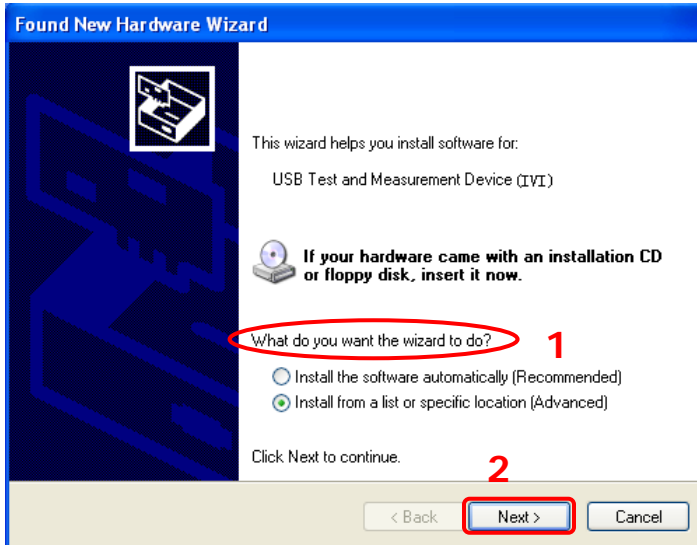

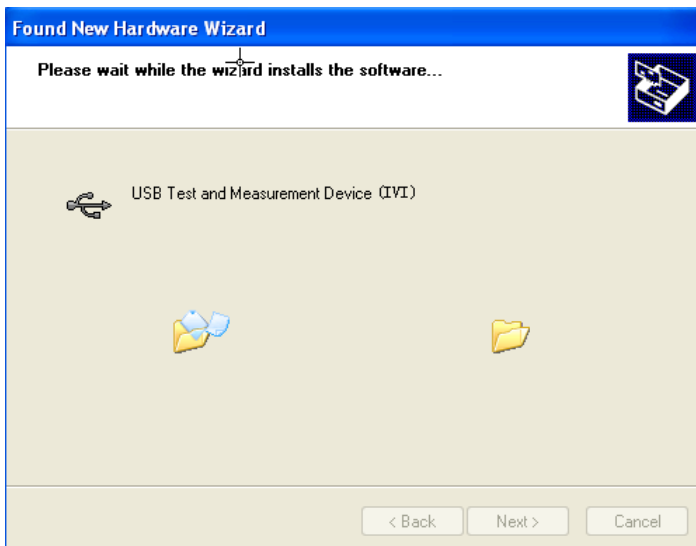
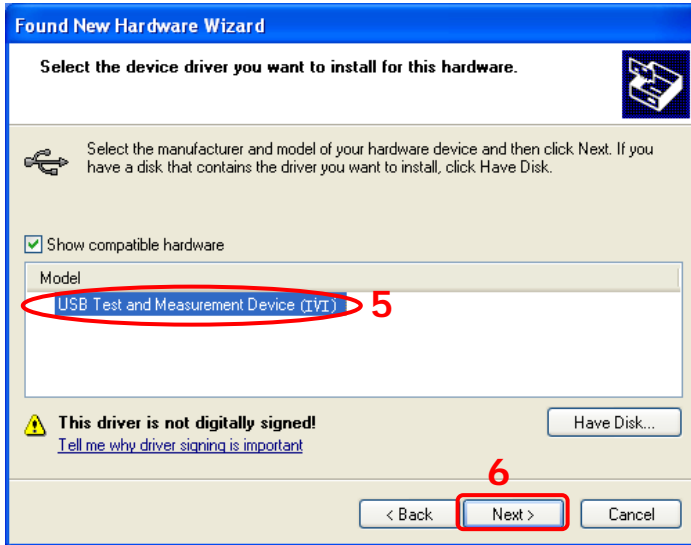

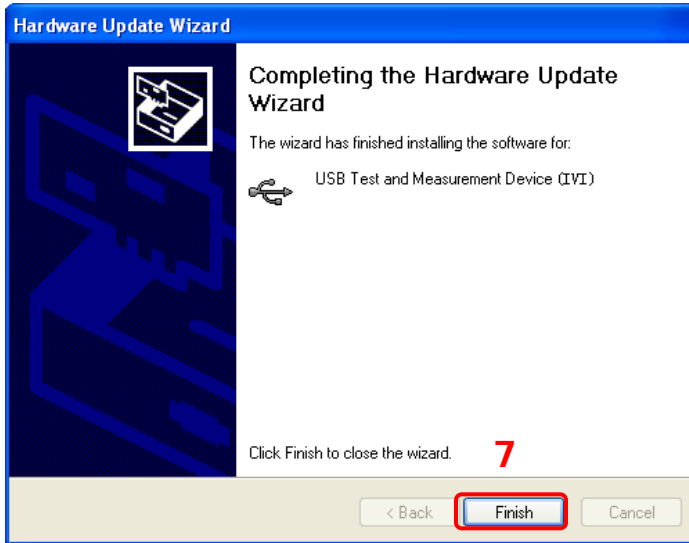

- **Using RS232 Interface:**

Convert the **[RS-232/Alarms/Ext Trig]** interface at the rear panel to two 9-pin interfaces using the Mixed Interface Convert Cable (accessory). Wherein, one is a 9-pin male interface used as a standard RS232 interface. Connect this interface with the computer using RS232 cable and set proper parameters according to **"To Set RS232 Parameters"**.

- **Using LAN Interface:**

Connect M300 to the LAN of the computer and set proper parameters according to **"To Set LAN Parameters"**.

3 Programming

Then, you can select a familiar software developing tool (such as LabVIEW, Matlab, Visual C++, etc.) for programming. For detailed information about SCPI commands and programming method of M300, refer to M300 Programming Guide.

To Use PC Software

You can control the instrument remotely by sending SCPI commands using PC software (**RIGOL** Ultra Sigma). This section introduces in details how to use Ultra Sigma to send commands through multiple interfaces to control M300. Please refer to Ultra Sigma Help to install the software and the components required correctly. About how to acquire the Ultra Sigma software, please contact with **RIGOL**.

To Control M300 through GPIB

1 Connect the device

Connect the instrument with the PC with GPIB card installed using GPIB cable before using the GPIB (General Purpose Interface Bus) Interface.

2 Install the driver of GPIB card

Install the driver of the GPIB card which has been connected to the PC correctly.

3 Set the GPIB address

Set the GPIB address of the instrument according to the description in “To Set GPIB Address”.

4 Search device resource

Start up the **Ultra Sigma** and click **GPIB** to open the panel as shown in the figure below. Click “Search” and the software will search the GPIB instrument resources connected to the PC. The device resources will be displayed on the right side of the panel.



If resources cannot be found automatically:

Select the GPIB card address of the PC from the dropdown box of “GPIBO::” and select the GPIB address set in the instrument from the dropdown box of “O::INSTR”. Click “Test” to check whether the GPIB communication works normally; if not, please follow the corresponding prompt messages to solve the problem.

5 View device resource

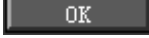
Click  to return back to the main interface of Ultra Sigma. The resources found will appear under the “RIGOL Online Resource” directory as shown in the figure below.



6 Communication Test

Right-click the resource name “M300 (GPIB0::7::INSTR)” to select “SCPI Panel Control” to turn on the remote command control panel through which you can send commands and read data.

To Control M300 through USB

1 Connect the devices

Connect M300 (USB Device) with your PC (USB Host) using USB cable.

2 Install the USB drive

As this instrument is a USB-TMC device, after you connect it to the PC and turn both on, the PC will display the hardware update wizard dialog box. Please install the "USB Test and Measurement Device (IVI)" driver following the directions of the wizard. The detailed steps are the same as the instruction in "User-defined Programming".

3 Search device resource

Start up Ultra Sigma, the software starts searching the generator resources currently connected to the PC automatically, or click **USB-TMC** to search manually. The status bar of Ultra Sigma at present is as shown in the figure below:

4 View the resource

The resources that have been searched successfully are shown under the "RIGOL Online Resource" catalog and the instrument model and the USB interface information are also displayed, as shown in the figure below.



5 Communicate test

Right click the resource name "M300 (USB0::0x1AB1::0x0C80::M300123123123::INSTR)" and select "SCPI Panel Control" to open the remote command control panel through which users can send commands and read data.

To Control M300 through RS232

1 Connect the devices

Convert the [RS-232/Alarms/Ext Trig] interface at the rear panel to two 9-pin interfaces using the Mixed Interface Convert Cable (accessory). Wherein, one is a 9-pin male interface used as a standard RS232 interface. Connect this interface with the computer using RS232 cable.

2 Set the RS232 parameters

Set proper parameters according to “To Set RS232 Parameters”.

3 Search device resource

Start up Ultra Sigma and click  to open the setting panel as shown in the figure below. Set the matched parameters (\r\n must be selected in End Mark) and click TEST. If the test succeeds, the instrument resources searched will be displayed in the right resource list. If not, please process according to the prompt message.



4 View the resource

Click “OK” to return the main interface of Ultra Sigma. The resources that have been searched successfully are shown under the “RIGOL Online Resource” catalog.



5 Communicate test

Right click the resource name "M300 (ASRL1::INSTR)" and select "SCPI Panel Control" to open the remote command control panel through which users can send commands and read data.

To Control M300 through LAN

1 Connect the devices

Connect M300 to your computer or the LAN of the computer using network cable.

2 Configure LAN parameters

1) DHCP mode:

If the network supports DHCP, the DHCP server in the network assigns network parameters (IP Address, Subnet Mask, Gateway and DNS) for M300 automatically.

2) Auto IP mode:

When the network doesn't support DHCP, the DHCP mode of M300 is disabled, or M300 is connected to the PC directly, the instrument selects Auto IP mode and acquires the IP address from 169.254.0.1 to 169.254.255.254, and subnet mask 255.255.0.0 automatically.

3) Manual IP mode:



Enable the Manual IP mode and disable the DHCP mode as well as the Auto IP mode to set the network parameters manually.

If M300 is connected to the PC directly, set the IP Addresses, Subnet Masks and Gateways for both of the PC and the instrument. The Subnet Masks and Gateways of M300 and PC must be the same and the IP Addresses of them must be within the same network segment (for details, refer to the TCP/IP protocol). An example is shown in the table below.

Network Parameters	PC	Instrument
IP Address	192.16.3.3	192.16.3.8
Subnet Mask	255.255.255.0	255.255.255.0
Default Gateway	192.16.3.1	192.16.3.1

If your M300 is connected to the LAN of your PC, please acquire a set of valid network parameters (IP Address, Subnet Mask, Gateway and DNS) and configure the network parameters of the instrument according to the description in "**To Set LAN Parameters**".

3 Search device resource

Start up Ultra Sigma, click  and click  in the pop-up window. Ultra Sigma searches for the instrument resources currently connected to the LAN and the resources found are displayed at the right of the window. Select the desired resource name and click  to add it, as shown in the figures below.

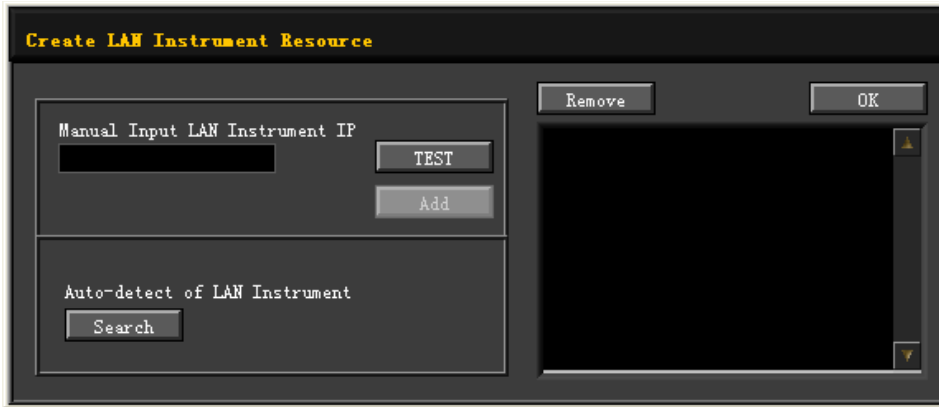

(a)

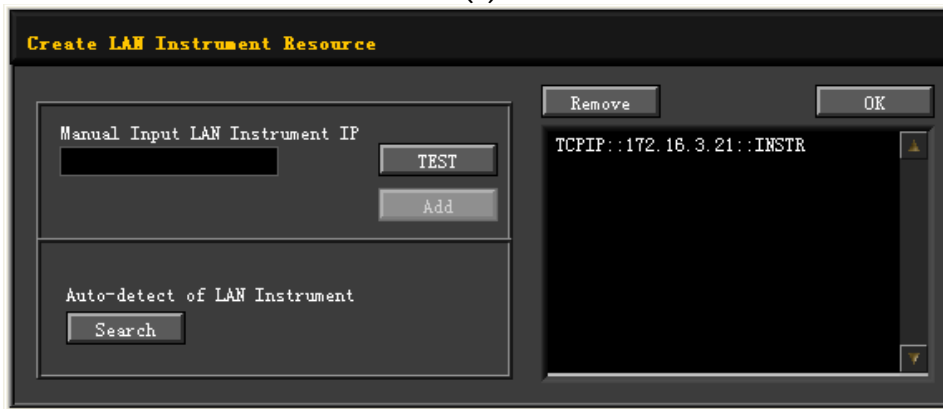

(b)

4 View device resource

The resources found will appear under the “RIGOL Online Resource” directory as shown in the figure below.



5 Communication test

Right click the resource name "M300(TCPIP::172.16.3.21::INSTR)" to select "SCPI Panel Control" to turn on the remote command control panel through which you can send commands and read data.

6 Load LXI webpage

As this instrument conforms to LXI Core 2011 Device standards, you can load the LXI webpage through Ultra Sigma (right-click the resource name and select LXI-Web; or directly input the IP address in the browser). Information about the instrument (model, manufacturer, serial number, description, MAC address and IP address) will be displayed on the webpage.

Chapter 5 Troubleshooting

This section lists some questions and failures which might occur when using this instrument. Please solve them according to the following method. If the problem remains, please contact **RIGOL** and provide the device information of your instrument (**Utility** → **Info**).

1. The instrument does not start.

- 1) Check the power cable connection.
- 2) Check whether the power switch at the front panel is turned on.
- 3) Remove the power cord and check whether the voltage selector is at the proper scale and whether the fuse specification is correct and the fuse is in good condition. To replace the fuse refer to the instructions.
- 4) Restart the instrument after executing the above steps.
- 5) If the problem remains, please contact **RIGOL**.

2. The USB storage device cannot be recognized.

- 1) Check whether the USB storage device can work normally.
- 2) Make sure the USB storage device used is Flash storage type, as this instrument does not support hardware storage type USB storage device.
- 3) Restart the instrument and insert the USB storage device to check it.
- 4) If the USB storage device still cannot work normally, please contact **RIGOL**.



3. How to recover the configurations from the last power failure or unexpected shutdown and continue the work before the shutdown automatically?

- 1) Restart the instrument.
- 2) Press **Utility** → **System**, select **Power-off** using the up/down direction key and select "ON" using the left/right direction key.

4. The screen is too dark?

Press **Utility** → **System**, select **Brightness** using the up/down direction key and set the proper brightness using the left/right direction key.

5. The instrument is locked?

- 1) Check whether the instrument is in remote mode (namely check whether "Rmt" is displayed in the status bar of the interface). If yes, press the  key to exit the remote mode and unlock the instrument.
- 2) Check whether the front panel of the instrument is locked (namely check whether  is displayed in the status bar of the interface). If yes, press and hold the  key to unlock the front panel.
- 3) Check whether a progress bar is displayed in the interface. If yes, please wait for a moment and operate the instrument when the progress bar

disappears.

- 4) If the problem remains, please restart the instrument.

6. How to change the system language?

Press **Utility** → **System**, select **Language** using the up/down direction key and select your desired language using the left/right direction key.

7. How to view the information and model number of the plug-in modules?

Press **Utility** → **Test**, select the desired module using the left/right direction key and press **View** to view the information of the module currently selected, including the function, model, serial number and version.

8. The corresponding indicator at the front panel does not go on when the module has been inserted?

- 1) Press **Utility** → **Test**, select the desired module using the left/right direction key and press **Re-test**. If the problem remains, press **View** to view the information of the module.
- 2) If the information of the module does not been displayed correctly, please refer to the problem 9.
- 3) If the information of the module is displayed correctly, the module indicator is possibly damaged, please contact **RIGOL** to consult maintenance information.

9. Unable to view the information of the module or unable to use the module when the module has been inserted?

- 1) Turn the mainframe off, pluck the module from the mainframe and insert the module into the mainframe again firmly.
- 2) Restart the mainframe, wait for about 1 minute and view the module information again.
- 3) If the problem remains, please contact **RIGOL**.

10. Unable to do the configurations or operations related to the DMM module when it has been inserted?

- 1) Ensure the setting of **Utility** → **System** → **DMM** is "ON". If the problem remains, please refer to the next step.
- 2) Press **Utility** → **Test**, select the DMM module using the left/right direction key and press **View** to view the information of the DMM module. If the information does not been displayed or displayed correctly, the DMM module is abnormal due to high current or power load failure probably. At this point, please turn the mainframe off and restart it a few minutes later.
- 3) If the problem remains, please contact **RIGOL**.

11. The GPIB interface does not work normally?

- 1) Check whether the cable works normally and the connection is correct and reliable.
- 2) Ensure the GPIB addresses of M300 and computer are identical.
- 3) If the problem remains, please contact **RIGOL**.

12. The USB Device interface does not work normally?

- 1) Check whether the cable works normally and the connection is correct and reliable.
- 2) Check whether the "USB Test and Measurement Device" drive program has been installed in your computer (namely check whether "USB Test and Measurement Devices" is displayed in the device manager of your computer).
- 3) If the problem remains, please contact **RIGOL**.

13. The RS232 interface does not work normally?

- 1) Ensure the RS232 parameters (baud rate, etc.) of M300 and computer are identical. If the problem remains, please refer to the next step.
- 2) Check whether the RS232 cable is a cross line.
- 3) If the problem remains, please contact **RIGOL**.

14. The LAN interface does not work normally?

- 1) Check whether the cable works normally and the connection is correct and reliable.
- 2) Check the IP address configuration mode:
 - If DHCP is enabled, please ensure the network supports DHCP mode and can distribute network parameters (such as the IP address) to the instrument automatically.
 - If DHCP is disabled and Auto IP is enabled, please ensure the IP addresses of M300 and computer is in the same network segment.
 - If Manual IP is enabled, please ensure the IP addresses of M300 and computer is in the same network segment.
- 3) If the problem remains, please contact **RIGOL**.

Chapter 6 Specifications

DC Characteristics

Accuracy Specifications: \pm (% of reading + % of range) ^[1]

Function	Range ^[2]	Test Current or Load Voltage	24 Hour ^[3] T _{CAL} °C \pm 1 °C	90 Day T _{CAL} °C \pm 5 °C	1 Year T _{CAL} °C \pm 5 °C	Temperature Coefficient 0 °C to (T _{CAL} °C - 5 °C) (T _{CAL} °C + 5 °C) to 50 °C
DC Voltage	200.0000mV	-	0.0020 + 0.0020	0.0030 + 0.0025	0.0040 + 0.0025	0.0005 + 0.0005
	2.000000V	-	0.0015 + 0.0005	0.0020 + 0.0006	0.0035 + 0.0006	0.0005 + 0.0001
	20.00000V	-	0.0020 + 0.0004	0.0030 + 0.0005	0.0040 + 0.0005	0.0005 + 0.0001
	200.0000V	-	0.0020 + 0.0006	0.0040 + 0.0006	0.0050 + 0.0006	0.0005 + 0.0001
	300.000V	-	0.0020 + 0.0006	0.0040 + 0.0010	0.0055 + 0.0010	0.0005 + 0.0001
DC Current	200.0000 μ A	<0.03V	0.010 + 0.012	0.040 + 0.015	0.050 + 0.015	0.0020 + 0.0030
	2.000000mA	<0.25V	0.007 + 0.003	0.030 + 0.003	0.050 + 0.003	0.0020 + 0.0005
	20.00000mA	<0.07V	0.007 + 0.012	0.030 + 0.015	0.050 + 0.015	0.0020 + 0.0020
	200.0000mA	<0.7V	0.010 + 0.002	0.030 + 0.003	0.050 + 0.003	0.0020 + 0.0005
	1.000000A	<0.12V	0.050 + 0.020	0.080 + 0.020	0.100 + 0.020	0.0050 + 0.0010
Resistance ^[4]	200.0000 Ω	1mA	0.0030 + 0.0030	0.008 + 0.004	0.010 + 0.004	0.0006 + 0.0005
	2.000000k Ω	1mA	0.0020 + 0.0005	0.008 + 0.001	0.010 + 0.001	0.0006 + 0.0001
	20.00000k Ω	100 μ A	0.0020 + 0.0005	0.008 + 0.001	0.010 + 0.001	0.0006 + 0.0001
	200.0000k Ω	10 μ A	0.0020 + 0.0005	0.008 + 0.001	0.010 + 0.001	0.0006 + 0.0001
	1.000000M Ω	2 μ A	0.002 + 0.001	0.010 + 0.001	0.012 + 0.001	0.0010 + 0.0002
	10.00000M Ω	200nA	0.015 + 0.001	0.030 + 0.001	0.040 + 0.001	0.0030 + 0.0004
	100.0000M Ω	200nA 10M Ω	0.300 + 0.010	0.800 + 0.010	0.800 + 0.010	0.1500 + 0.0002

[1] Specifications are for 90-minute warm-up and 100 PLC integration time.

[2] 10% overrange on all ranges.

[3] Relative to calibration standards.

[4] Specifications are for 4-wire resistance measurement. Add 3 Ω additional error in 2-wire resistance measurement.

Measuring Characteristics

DC Voltage	
Input Impedance	200mV, 2V, 20V ranges: 10M Ω or >10G Ω (For these ranges, input beyond ± 26 V are clamped through 106 k Ω) 200V and 300V ranges: 10M Ω \pm 1%
Input Protection	300V
Input Offset Current	50pA, at 25 $^{\circ}$ C, typical
CMRR (common mode rejection ratio)	140 dB for 1 k Ω unbalanced resistance in LO lead, \pm 300 VDC peak maximum.
Resistance	
Measurement Method	4-wire or 2-wire resistance Current source referenced to LO input
Open-circuit Voltage	Limited to <10 V
Max. Lead Resistance (4-wire)	10% of range per lead for 200 Ω and 2 k Ω ranges, 1 k Ω per lead on all other ranges
Input Protection	300V on all ranges
Offset Compensation	Available on 200 Ω , 2 k Ω and 20 k Ω ranges.
DC Current	
Shunt Resistor	100 Ω for 200 μ A, 2 mA 1 Ω for 20 mA, 200 mA 0.01 Ω for 2 A, 10 A
Auto Zero OFF Operation (typical value)	
Following instrument warm-up at the environment temperature \pm 1 $^{\circ}$ C and <5 minutes, add 0.0001 % range + 2 μ V error for DCV and 2 m Ω error for resistance.	
Settling Considerations	
Reading settling times are affected by source impedance, cable dielectric characteristics and input signal changes. The default measurement delay can ensure the correctness of the first reading for most measurements.	
Measurement Considerations	
Teflon or other high-impedance, low-dielectric absorption wire insulation is recommended for these measurements.	

AC Characteristics

Accuracy Specifications: \pm (% of reading + % of range) ^[1]

Function	Range ^[2]	Frequency Range	24 Hour ^[3] T _{CAL} °C \pm 1°C	90 Day T _{CAL} °C \pm 5°C	1 Year T _{CAL} °C \pm 5°C	Temperature Coefficient 0°C to (T _{CAL} °C - 5°C) (T _{CAL} °C + 5°C) to 50°C
True RMS AC Voltage ^[4]	200.0000mV	3Hz- 5Hz	1.00 + 0.03	1.00 + 0.04	1.00 + 0.04	0.100 + 0.004
		5Hz-10Hz	0.35 + 0.03	0.35 + 0.04	0.35 + 0.04	0.035 + 0.004
		10Hz-20kHz	0.04 + 0.03	0.05 + 0.04	0.06 + 0.04	0.005 + 0.004
		20kHz-50kHz	0.10 + 0.05	0.11 + 0.05	0.12 + 0.05	0.011 + 0.005
		50kHz-100kHz	0.55 + 0.08	0.60 + 0.08	0.60 + 0.08	0.060 + 0.008
		100kHz- 300kHz	4.00 + 0.50	4.00 + 0.50	4.00 + 0.50	0.20 + 0.02
	2.000000V	3Hz-5Hz	1.00 + 0.02	1.00 + 0.03	1.00 + 0.03	0.100 + 0.003
		5Hz-10Hz	0.35 + 0.02	0.35 + 0.03	0.35 + 0.03	0.035 + 0.003
		10Hz-20kHz	0.04 + 0.02	0.05 + 0.03	0.06 + 0.03	0.005 + 0.003
		20kHz-50kHz	0.10 + 0.04	0.11 + 0.05	0.12 + 0.05	0.011 + 0.005
		50kHz-100kHz	0.55 + 0.08	0.60 + 0.08	0.60 + 0.08	0.060 + 0.008
		100kHz-300kHz	4.00 + 0.50	4.00 + 0.50	4.00 + 0.50	0.20 + 0.02
	20.00000V	3Hz-5Hz	1.00 + 0.03	1.00 + 0.04	1.00 + 0.04	0.100 + 0.004
		5Hz-10Hz	0.35 + 0.03	0.35 + 0.04	0.35 + 0.04	0.035 + 0.004
		10Hz-20kHz	0.04 + 0.04	0.07 + 0.04	0.08 + 0.04	0.008 + 0.004
		20kHz- 50kHz	0.10 + 0.05	0.12 + 0.05	0.15 + 0.05	0.012 + 0.005
		50kHz-100kHz	0.55 + 0.08	0.60 + 0.08	0.60 + 0.08	0.060 + 0.008
		100kHz-300kHz	4.00 + 0.50	4.00 + 0.50	4.00 + 0.50	0.20 + 0.02
	200.0000V	3Hz-5Hz	1.00 + 0.02	1.00 + 0.03	1.00 + 0.03	0.100 + 0.003
		5Hz-10Hz	0.35 + 0.02	0.35 + 0.03	0.35 + 0.03	0.035 + 0.003
		10Hz-20kHz	0.04 + 0.02	0.07 + 0.03	0.08 + 0.03	0.008 + 0.003
		20kHz-50kHz	0.10 + 0.04	0.12 + 0.05	0.15 + 0.05	0.012 + 0.005
		50kHz-100kHz	0.55 + 0.08	0.60 + 0.08	0.60 + 0.08	0.060 + 0.008
		100kHz-300kHz	4.0 + 0.50	4.0 + 0.50	4.0 + 0.50	0.20 + 0.02
300.000V	3Hz-5Hz	1.00 + 0.02	1.00 + 0.03	1.00 + 0.03	0.100 + 0.003	

		5Hz-10Hz	0.35 + 0.02	0.35 + 0.03	0.35 + 0.03	0.035 + 0.003
		10Hz-20kHz	0.04 + 0.02	0.07 + 0.03	0.08 + 0.03	0.008 + 0.003
		20kHz-50kHz	0.10 + 0.04	0.12 + 0.05	0.15 + 0.05	0.012 + 0.005
		50kHz-100kHz	0.55 + 0.08	0.60 + 0.08	0.60 + 0.08	0.060 + 0.008
		100kHz-300kHz	4.0 + 0.50	4.0 + 0.50	4.0 + 0.50	0.20 + 0.02
True RMS AC Current [8]	200.0000μA	3Hz-5Hz	1.10 + 0.06	1.10 + 0.06	1.10 + 0.06	0.200 + 0.006
		5Hz-10Hz	0.35 + 0.06	0.35 + 0.06	0.35 + 0.06	0.100 + 0.006
		10Hz-5kHz	0.15 + 0.06	0.15 + 0.06	0.15 + 0.06	0.015 + 0.006
		5kHz-10kHz	0.35 + 0.70	0.35 + 0.70	0.35 + 0.70	0.030 + 0.006
	2.000000mA	3Hz-5Hz	1.00 + 0.04	1.00 + 0.04	1.00 + 0.04	0.100 + 0.006
		5Hz-10Hz	0.30 + 0.04	0.30 + 0.04	0.30 + 0.04	0.035 + 0.006
		10Hz-5kHz	0.12 + 0.04	0.12 + 0.04	0.12 + 0.04	0.015 + 0.006
		5kHz-10kHz	0.20 + 0.25	0.20 + 0.25	0.20 + 0.25	0.030 + 0.006
	20.00000mA	3Hz-5Hz	1.10 + 0.06	1.10 + 0.06	1.10 + 0.06	0.200 + 0.006
		5Hz-10Hz	0.35 + 0.06	0.35 + 0.06	0.35 + 0.06	0.100 + 0.006
		10Hz-5kHz	0.15 + 0.06	0.15 + 0.06	0.15 + 0.06	0.015 + 0.006
		5kHz-10kHz	0.35 + 0.70	0.35 + 0.70	0.35 + 0.70	0.030 + 0.006
	200.0000mA	3Hz-5Hz	1.00 + 0.04	1.00 + 0.04	1.00 + 0.04	0.100 + 0.006
		5Hz-10Hz	0.30 + 0.04	0.30 + 0.04	0.30 + 0.04	0.035 + 0.006
		10Hz-5kHz	0.10 + 0.04	0.10 + 0.04	0.10 + 0.04	0.015 + 0.006
		5kHz-10kHz	0.20 + 0.25	0.20 + 0.25	0.20 + 0.25	0.030 + 0.006
	1.000000A	3Hz-5Hz	1.10 + 0.06	1.10 + 0.06	1.10 + 0.06	0.100 + 0.006
		5Hz-10Hz	0.35 + 0.06	0.35 + 0.06	0.35 + 0.06	0.035 + 0.006
		10Hz-5kHz	0.15 + 0.06	0.15 + 0.06	0.15 + 0.06	0.015 + 0.006
		5kHz-10kHz	0.35 + 0.70	0.35 + 0.70	0.35 + 0.70	0.030 + 0.006
5Hz-10Hz		0.35 + 0.08	0.35 + 0.10	0.35 + 0.10	0.035 + 0.008	
10Hz-5kHz		0.15 + 0.08	0.15 + 0.10	0.15 + 0.10	0.015 + 0.008	

[1] Specifications are for 90-minute warm-up, slow ac filter and sine wave input.

[2] 10% overrange on all ranges.

[3] Relative to calibration standards.

[4] Specifications are for sine wave input >5% of range. For inputs from 1% to 5% of range and <50 kHz, add 0.1% of range additional error. For

50 kHz to 100 kHz, add 0.13% of range.

- [5] When the frequency is lower than 100 Hz, the specification of slow filter is only for sine wave input.
- [6] Specifications are for sine wave input >5% of range. For inputs from 1% to 5% of range, add 0.1% of range additional error. Specifications are typical values for 200 μ A, 2 mA, 2 A and 10 A ranges when frequency is >1 kHz.

Measuring Characteristics

True RMS AC Voltage	
Measurement Method	AC-coupled True-RMS -- measure the ac component of input with up to 300 V DC bias on any range.
Crest Factor	≤ 5 at full range
Input Impedance	1 M Ω \pm 2%, in parallel with <150 pF capacitance on any range
Input Protection	300 Vrms on all ranges
AC Filter Bandwidth	Slow: 3 Hz – 300 kHz
	Medium: 20 Hz – 300 kHz
	Fast: 200 Hz – 300 kHz
CMRR (common mode rejection ratio)	70 dB, for the 1 k Ω unbalance in LO lead, <60 Hz common mode signal frequency, \pm 300 Vpeak maximum.
True RMS AC Current	
Measurement Method	Direct coupled to the fuse and shunt; AC-coupled True RMS measurement (measure the AC component).
Crest Factor	≤ 3 at full range
Max. Input	DC + AC current peak value <300% of range. Current with DC current component <1 Arms.
Shunt Resistor	100 Ω for 200 μ A, 2 mA
	1 Ω for 20 mA, 200 mA
	0.01 Ω for 1 A
Settling Time Considerations	
The default measurement delay of the multimeter can ensure the correctness of the first readings of most of the measurements. Make sure the RC circuit of input terminal has been fully settled (about 1 s) before accurate measurement.	

Frequency and Period Characteristics

Accuracy Specifications: \pm (% of reading) ^{[1] [2]}

Function	Range	Frequency Range	24 Hour ^[3] $T_{CAL} \text{ } ^\circ\text{C} \pm 1^\circ\text{C}$	90 Day $T_{CAL} \text{ } ^\circ\text{C} \pm 5^\circ\text{C}$	1 Year $T_{CAL} \text{ } ^\circ\text{C} \pm 5^\circ\text{C}$	Temperature Coefficient 0°C to ($T_{CAL} \text{ } ^\circ\text{C} - 5^\circ\text{C}$) ($T_{CAL} \text{ } ^\circ\text{C} + 5^\circ\text{C}$) to 50°C
Frequency, Period	200mV to 300V	3 Hz-5 Hz	0.07	0.07	0.07	0.005
		5 Hz-10 Hz	0.04	0.04	0.04	0.005
		10 Hz-40 Hz	0.02	0.02	0.02	0.001
		40 Hz-300 kHz	0.005	0.006	0.007	0.001
		300 kHz-1 MHz	0.005	0.006	0.007	0.001

Additional Low Frequency Errors: (% of reading)

Frequency	Gate Time (Resolution)			
	1 s (0.1 ppm)	0.1 s (1 ppm)	0.01 s (10 ppm)	0.001 s (100 ppm)
3 Hz-5Hz	0	0.12	0.12	0.12
5 Hz-10Hz	0	0.17	0.17	0.17
10 Hz-40Hz	0	0.20	0.20	0.20
40 Hz-100Hz	0	0.06	0.21	0.21
100 Hz-300Hz	0	0.03	0.21	0.21
300 Hz-1 kHz	0	0.01	0.07	0.07
>1kHz	0	0	0.02	0.02

[1] Specifications are for 90 minutes warm-up and 1 s gate time.

[2] For frequency ≤ 300 kHz, the specification is for AC input voltage of 10% to 110% of range. For frequency > 300 kHz, the specification is for AC input voltage of 20% to 110% of range. The maximum input is limited to 750 Vrms or 8×10^7 Volts-Hz (whichever is less). 200 mV range is full range input or input that is larger than the full range. For 20 mV to 200 mV inputs, multiply % of reading error by 10.

[3] Relative to calibration standards.

Measuring Characteristics**Frequency and Period**

Measurement Method	Reciprocal-counting technique, AC-coupled input using the AC voltage function.
Input Impedance	1 M Ω \pm 2%, in parallel with <150 pF capacitance on any range
Input Protection	300 Vrms on all ranges

Measurement Considerations

All frequency counters are susceptible to error when measuring low-voltage, low-frequency signals. Shielding inputs from external noise pickup is critical for minimizing measurement errors.

Settling Considerations

Errors will occur when attempting to measure the frequency or period of an input following a dc offset voltage change. The input blocking RC time constant must be allowed to fully settle (about 1 s) before the most accurate measurements are possible.

Temperature Characteristics

Function	Probe Type	Type	Optimum Range	Accuracy Specifications ^[1]	
				1 Year $T_{CAL} \text{ } ^\circ\text{C} \pm 5^\circ\text{C}$	Temperature Coefficient $0^\circ\text{C to } (T_{CAL} \text{ } ^\circ\text{C} - 5^\circ\text{C})$ $(T_{CAL} \text{ } ^\circ\text{C} + 5^\circ\text{C}) \text{ to } 50^\circ\text{C}$
Temperature	RTD ^[2] (R_0 is within 49 Ω and 2.1 k Ω)	$\alpha=0.00385$	-200 $^\circ\text{C}$ to 660 $^\circ\text{C}$	0.16 $^\circ\text{C}$	0.01 $^\circ\text{C}$
		$\alpha=0.00389$	-200 $^\circ\text{C}$ to 660 $^\circ\text{C}$	0.17 $^\circ\text{C}$	0.01 $^\circ\text{C}$
		$\alpha=0.00391$	-200 $^\circ\text{C}$ to 660 $^\circ\text{C}$	0.14 $^\circ\text{C}$	0.01 $^\circ\text{C}$
		$\alpha=0.00392$	-200 $^\circ\text{C}$ to 60 $^\circ\text{C}$	0.15 $^\circ\text{C}$	0.01 $^\circ\text{C}$
	Thermal Resistance	2.2 k Ω	-40 $^\circ\text{C}$ to 150 $^\circ\text{C}$	0.08 $^\circ\text{C}$	0.002 $^\circ\text{C}$
		3 k Ω	-40 $^\circ\text{C}$ to 150 $^\circ\text{C}$	0.08 $^\circ\text{C}$	0.002 $^\circ\text{C}$
		5 k Ω	-40 $^\circ\text{C}$ to 150 $^\circ\text{C}$	0.08 $^\circ\text{C}$	0.002 $^\circ\text{C}$
		10 k Ω	-40 $^\circ\text{C}$ to 150 $^\circ\text{C}$	0.08 $^\circ\text{C}$	0.002 $^\circ\text{C}$
		30 k Ω	-40 $^\circ\text{C}$ to 150 $^\circ\text{C}$	0.08 $^\circ\text{C}$	0.002 $^\circ\text{C}$
	Thermocouple ^[3]	B	0 $^\circ\text{C}$ to 1820 $^\circ\text{C}$	0.76 $^\circ\text{C}$	0.14 $^\circ\text{C}$
		E	-270 $^\circ\text{C}$ to 1000 $^\circ\text{C}$	0.5 $^\circ\text{C}$	0.02 $^\circ\text{C}$
		J	-210 $^\circ\text{C}$ to 1200 $^\circ\text{C}$	0.5 $^\circ\text{C}$	0.02 $^\circ\text{C}$
		K	-270 $^\circ\text{C}$ to 1372 $^\circ\text{C}$	0.5 $^\circ\text{C}$	0.03 $^\circ\text{C}$
		N	-270 $^\circ\text{C}$ to 1300 $^\circ\text{C}$	0.5 $^\circ\text{C}$	0.04 $^\circ\text{C}$
		R	-50 $^\circ\text{C}$ to 1768.1 $^\circ\text{C}$	0.5 $^\circ\text{C}$	0.09 $^\circ\text{C}$
		S	-50 $^\circ\text{C}$ to 1768.1 $^\circ\text{C}$	0.6 $^\circ\text{C}$	0.11 $^\circ\text{C}$
	T	-270 $^\circ\text{C}$ to 400 $^\circ\text{C}$	0.5 $^\circ\text{C}$	0.03 $^\circ\text{C}$	

[1] Specifications are for 90 minutes warm-up. Probe error excluded.

[2] Specification is for 4WR resistance measurement.

[3] Relative to cold junction temperature, accuracy is based on ITS-90. Built-in cold junction temperature refers to the temperature inside the banana jack and its accuracy is $\pm 2.5 \text{ } ^\circ\text{C}$.

Measuring Characteristics

Thermocouple	
Conversion	ITS-90 software compensation
Reference Junction Type	Internal, Fixed, or External
T/C Check	Selectable per channel. When the channel resistance is $>5k\Omega$, it is considered as Open.
RTD	
Alpha	= 0.00385 (DIN/IEC 751): using ITS-90 software compensation; = 0.00389, 0.00391 or 0.00392: using IPTS-68 software compensation
Thermistor	
	44004, 44007, 44006 series
Measurement Considerations	
The built-in cold junction temperature tracks the temperature inside the terminal block. The change of temperature in the terminal block might cause additional error. When using the built-in cold junction compensation, connect the sensor terminal of the thermocouple to the terminal block and warm it up for more than 3 minutes to minimize the error.	

Module Specifications

MC3120/MC3132/MC3164/MC3324/MC3416/MC3648

	Multiplexer				Actuator	Matrix
General	MC3120	MC3132	MC3164	MC3324	MC3416	MC3648
Number of Channels	20	32	64	20 Voltage+4 Current	16	4×8
	2/4 wire ^[1]	2/4 wire ^[1]	1 wire ^[2]	2/4 wire ^[3]	SPDT	2 wire
Connect to DMM Module?	Yes	Yes	Yes	Yes	No	No
Scanning Speed ^[4]	60Ch/s	60Ch/s	60Ch/s	60Ch/s	--	--
Open/Close Speed	200Ch/s	200Ch/s	200Ch/s	200Ch/s	200Ch/s	200Ch/s
Maximum Input						
Voltage (DC, AC rms)	300Vrms	300Vrms	300Vrms	300Vrms	300Vrms	300Vrms
Current (DC, AC rms)	1Arms	1Arms	1Arms	1Arms	2Arms	1Arms
Power (W, VA)	50VA	50VA	50VA	50VA	60VA	50VA
Isolation (ch-ch, ch-earth) (DC, AC rms)	300Vrms	300Vrms	300Vrms	300Vrms	300Vrms	300Vrms
DC Characteristics						
Offset Voltage	5uV	5uV	5uV	5uV	<3uV	5uV
Initial Closed Channel Resistance	<1Ω	<1Ω	<1Ω	<1Ω	<0.1Ω	<1Ω
Isolation (ch-ch, ch-earth)	>10GΩ	>10GΩ	>10GΩ	>10GΩ	>10GΩ	>10GΩ
AC Characteristics						
Bandwidth	1MHz	1MHz	1MHz	1MHz	1MHz	1MHz
Ch-Ch Cross Talk (dB) ^[5] 1MHz	-45	-45	-18 ^[6]	-45	-15	-18
Capacitance HI-LO	100pF	100pF	100pF	100pF	<500pF	100pF
Capacitance LO-Earth	200pF	200pF	200pF	200pF	<200pF	200pF

Volt-Hertz Limit	10 ⁸	10 ⁸	10 ⁸	10 ⁸	10 ⁸	10 ⁸
Other						
T/C Cold Junction Accuracy (Typical)	0.8°C	0.8°C	0.8°C ^[7]	0.8°C	--	--
Switch Life (No Load) (Typical)	100M	100M	100M	100M	100M	100M
Switch Life (Rated Load) (Typical) ^[8]	100K	100K	100K	100K	100K	100K
Operating Temperature	0°C - 55°C	0°C - 55°C	0°C - 55°C	0°C - 55°C	0°C - 55°C	0°C - 55°C
Storage Temperature	-20°C - 70°C	-20°C - 70°C	-20°C - 70°C	-20°C - 70°C	-20°C - 70°C	-20°C - 70°C
Humidity (non-condensing)	40°C/ 80% RH	40°C/80% RH	40°C/80% RH	40°C/80% RH	40°C/80% RH	40°C/80% RH

- [1] The 20-channel multiplexer can be used as 20 two-wire measurement channels or 10 four-wire measurement channels. The 32-channel multiplexer can be used as 32 two-wire measurement channels or 16 four-wire measurement channels.
- [2] The 2 groups of channels (32 channels per group) of the 64-channel multiplexer use the same LO terminal.
- [3] The 24-channel multiplexer can be used as 20 two-wire measurement channels or 10 four-wire measurement channel and 4 current channels.
- [4] Integration time: 0.02PLC, channel delay: 0, auto zero: off, alarm: off, scaling: off, display: off, data to internal memory, the results are measured under the DCV function.
- [5] Matching impedance is 50Ω.
- [6] The isolation between banks is greater than 40dB.
- [7] The thermocouple precision of this module depends on the LO setting rather than the temperature of the cold terminal.
- [8] Only for resistive loads.

MC3534

Digital Input/Output (DIO)					
Port 1,2,3,4	8-bit, input or output, non-isolated				
Type	Vin(L)	Vin(H)	Vout(L)	Vout(H)	Vin(H) Max
TTL	<0.8V	>2.0V	<0.2V@I _{out} =-500mA	>4.8V@I _{out} =1mA	<42V with external open drain pull-up
5V CMOS	<1.5V	>3.5V	<0.2V@I _{out} =-500mA	>4.8V@I _{out} =1mA	
3.3V CMOS	<1.0V	>2.3V	<0.2V@I _{out} =-500mA	>3.15V@I _{out} =1mA	
2.5V CMOS	<0.75V	>1.75V	<0.2V@I _{out} =-500mA	>2.35V@I _{out} =1mA	
User defined	Threshold-0.3V	Threshold+0.3V	<0.2V@I _{out} =-500mA	>(Level-0.2V)@I _{out} =1mA	
Alarming	Match or mismatch, maskable				Match or mismatch, maskable
Speed	4ms (Max) alarm sampling				4ms (Max) alarm sampling
Latency	5ms				5ms
Read/Write Speed	100/s				100/s
Totalizer Input (TOT)					
	High Speed (TOT1,TOT2)		Normal Speed (TOT3,TOT4)		
Maximum Count	2 ³² -1		2 ³² -1		
Totalizer Input	10MHz (max), rising or falling edge, programmable		100kHz (max), rising or falling edge, programmable		
Signal Level	CMOS 3.3V, 5V tolerable		1Vp-p(min), 42Vpk(max), Vcm=-12V~+12V		
Threshold	Fixed at CMOS 3.3V		-12V~+12V, programmable		
Gated Input	CMOS 3.3V-Hi, CMOS 3.3V-Lo or none, 5V tolerance		CMOS 3.3V-Hi, CMOS 3.3V-Lo or none, 5V tolerance		
Count Reset	Manual or Read + Reset		Manual or Read + Reset		
Read Speed	100/s		100/s		
Analog Voltage Output (DAC)					
DAC 1,2,3,4	±12V, non-isolated (earth referenced)				
Resolution	1mV				
I_{out}	10mA max				
Setting Time	1ms to 0.01 % of output				

Accuracy 1 year ±5°C	±(% output + mV) 0.25%+20mV
Temp Coefficient	±(0.015%+1mV)/°C

General Specifications

Display	4.3 inches
Power Supply	AC 100V - 120V, 45Hz - 440Hz AC 200V - 240V, 45Hz - 66Hz Detect the power frequency automatically at power-on, 400 Hz defaults to 50 Hz
Power Consumption	25 VA Max
Working Environment	Full accuracy for 0°C to 50°C Full accuracy to 80% R.H. at 40°C Non-coagulation
Storage Temperature	-40°C to 70°C
Operation Altitude	Up to 2000m
Safety	IEC 61010-1; EN 61010-1; UL 61010-1; CAN/CSA-C22.2 No. 61010-1 Measurement CAT I 1000V/CAT II 300V Pollution Degree 2
EMC	EN 61326-1
Weight	About 5.7 kg (without package)
Dimension	(height × width × length): 159.0mm × 239.0mm × 373.4mm
Remote Interface	GPIB, 10/100Mbit LAN, USB 2.0 Full Speed Device & Host (support USB storage device), RS-232
Programming Language	SCPI
LXI Compatibility	LXI Core 2011 Device, Version 1.4
Warm-up Time	90 minutes

Chapter 7 Appendix

Appendix A: Accessories and Options List

	Description	Ordering No.
Mainframe	M300 Data Acquisition/Switch System	M300
	M300 Data Acquisition/Switch System + DMM Module	M301
	M300 Data Acquisition/Switch System + DMM Module + MC3120 20-Channel Multiplexer	M302
Standard Accessories	Power Cord conforming to the standard of the country	-
	USB Cable	CB-USBA-USBB-FF-150
	Mixed-interface Separator Line	MIX-SEPARATOR
	Four Spare Fuses: 2 AC, 250 V, T3.15 A fuses 2 AC, 250 V, T250 mA fuses	-
	Quick Guide	-
	Resource CD (User's Guide and Ultra Acquire)	-
Optional Accessories: Module	DMM Module (6½ digits)	MC3065
	20-channel Multiplexer	MC3120
	32-channel Multiplexer	MC3132
	64-channel Single-ended Multiplexer	MC3164
	20-voltage-channel+4-current-channel Mixed Multiplexer	MC3324
	16-channel Actuator	MC3416
	Multifunction Module	MC3534
	4×8 Matrix Switch	MC3648
Optional Accessories: Terminal Block	MC3120 Terminal Block	M3TB20
	MC3132 Terminal Block	M3TB32
	MC3164 Terminal Block	M3TB64
	MC3324 Terminal Block	M3TB24
	MC3648 Terminal Block	M3TB48
	MC3534 Terminal Block	M3TB34
	MC3416 Terminal Block	M3TB16
Optional Accessories	RS232 Serial Cable	-
	GPIB Invert Port	M3GPIB
	External Port for Analog Bus	A-BUS-EXT-PORT
	Rack Mount Kit	RM-1-M300
	Rack Mount Kit for Two Instruments	RM-2-M300
	PC Application Software for M300 Series	Ultra Acquire

Appendix B: Definitions of the Pins of the 78-pin Interface of the Plug-in Modules

MC3120

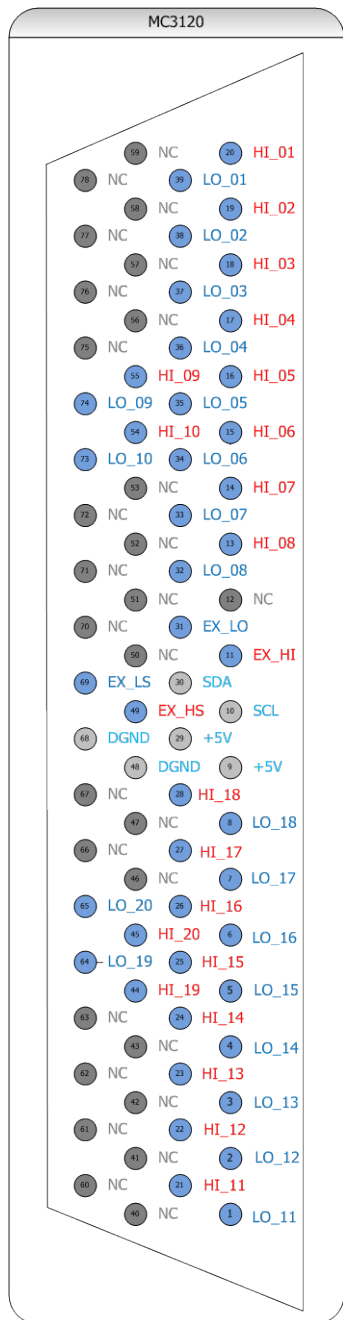

Pin Label	Pin Qty.	Definition
HI_n ^[1]	20	Correspond to the 20-channel differential positive input terminal on the external terminal block
LO_n ^[1]	20	Correspond to the 20-channel differential negative input terminal on the external terminal block
NC	28	Connection is forbidden
EX_HI	1	Correspond to the 2-W HI terminal on the external terminal block
EX_LO	1	Correspond to the 2-W LO terminal on the external terminal block
EX_HS	1	Correspond to the SENSE HI terminal on the external terminal block
EX_LS	1	Correspond to the SENSE LO terminal on the external terminal block
+5V	2	Connected to the digital temperature sensor (I ² C type) on the external terminal block
DGND	2	
SDA	1	
SCL	1	

Note^[1]: n is an integer from 01 to 20.

MC3132

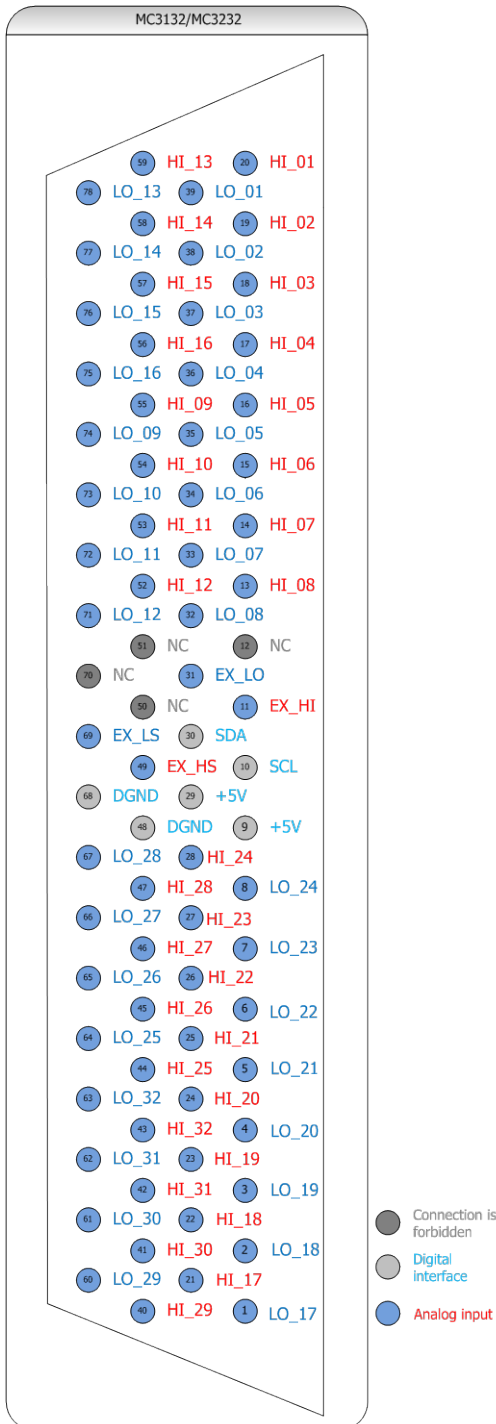

Pin Label	Pin Qty.	Definition
HI_n ^[1]	32	Correspond to the 32-channel differential positive input terminal on the external terminal block
LO_n ^[1]	32	Correspond to the 32-channel differential negative input terminal on the external terminal block
NC	4	Connection is forbidden
EX_HI	1	Correspond to the 2-W HI terminal on the external terminal block
EX_LO	1	Correspond to the 2-W LO terminal on the external terminal block
EX_HS	1	Correspond to the SENSE HI terminal on the external terminal block
EX_LS	1	Correspond to the SENSE LO terminal on the external terminal block
+5V	2	Connected to the digital temperature sensor (I ² C type) on the external terminal block
DGND	2	
SDA	1	
SCL	1	

Note^[1]: n is an integer from 01 to 32.

MC3164

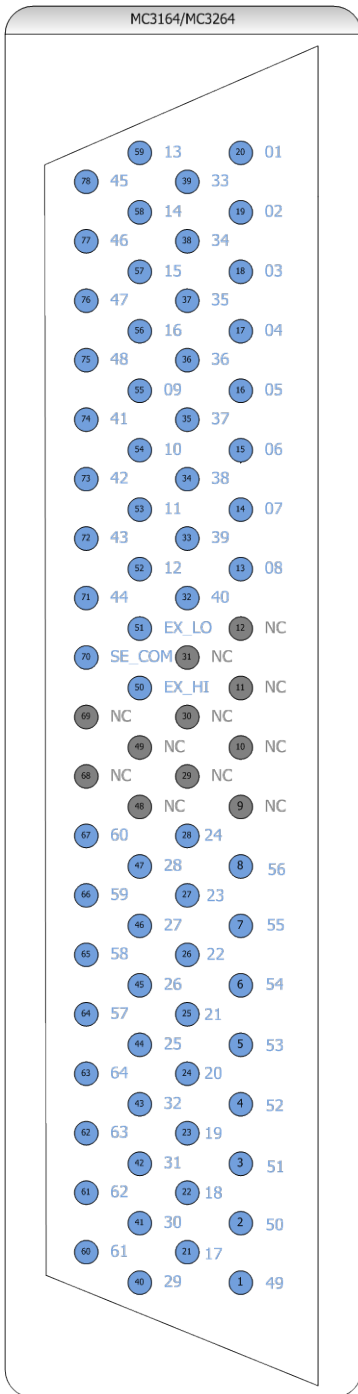

Pin Label	Pin Qty.	Definition
n ^[1]	64	Correspond to the 64-channel input terminal on the external terminal block
SE_COM	1	Correspond to the COM terminal on the external terminal block
NC	11	Connection is forbidden
EX_HI	1	Correspond to the HI terminal on the external terminal block
EX_LO	1	Correspond to the LO terminal on the external terminal block

Note^[1]: n is an integer from 01 to 64.

- Connection is forbidden
- Analog input

MC3324

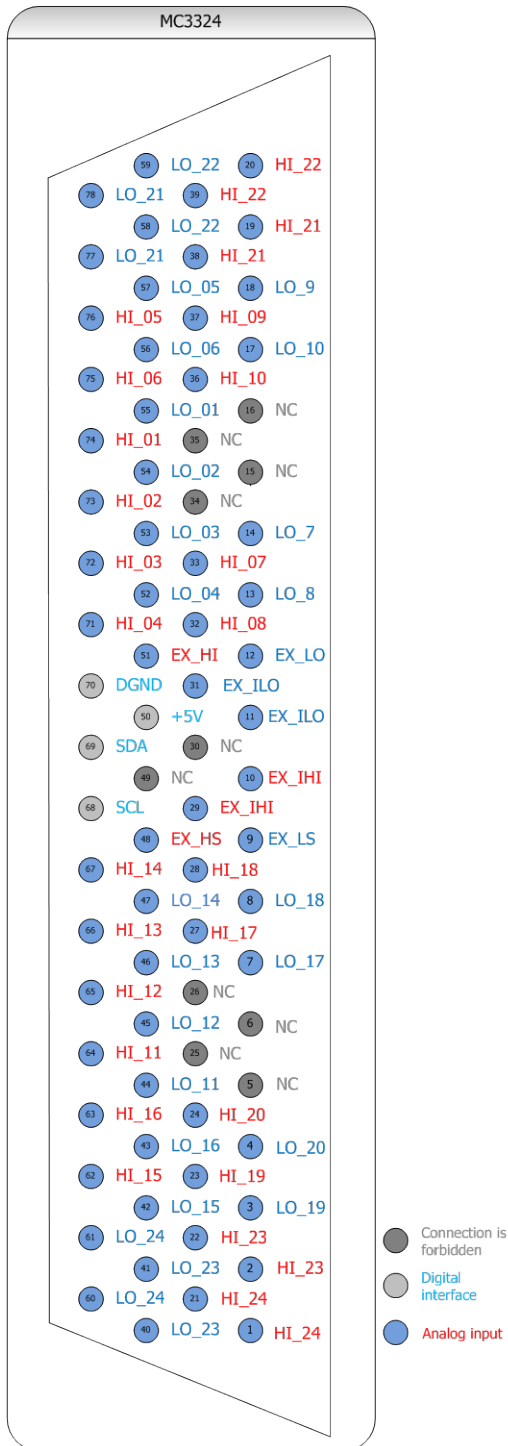

Pin Label	Pin Qty.	Definition
HI_n ^[1]	28	Correspond to the 24-channel differential positive input terminal on the external terminal block
LO_n ^[1]	28	Correspond to the 24-channel differential negative input terminal on the external terminal block
NC	10	Connection is forbidden
EX_HI	1	Correspond to the SOURCE HI terminal on the external terminal block
EX_LO	1	Correspond to the SOURCE LO terminal on the external terminal block
EX_HS	1	Correspond to the SENSE HI terminal on the external terminal block
EX_LS	1	Correspond to the SENSE LO terminal on the external terminal block
EX_ILO	1	Correspond to the CURR LO terminal on the external terminal block
EX_IHI	1	Correspond to the CURR HI terminal on the external terminal block
+5V	2	Connected to the digital temperature sensor (I ² C type) on the external terminal block
DGND	2	
SDA	1	
SCL	1	

Note^[1]: n is an integer from 01 to 24.

MC3416

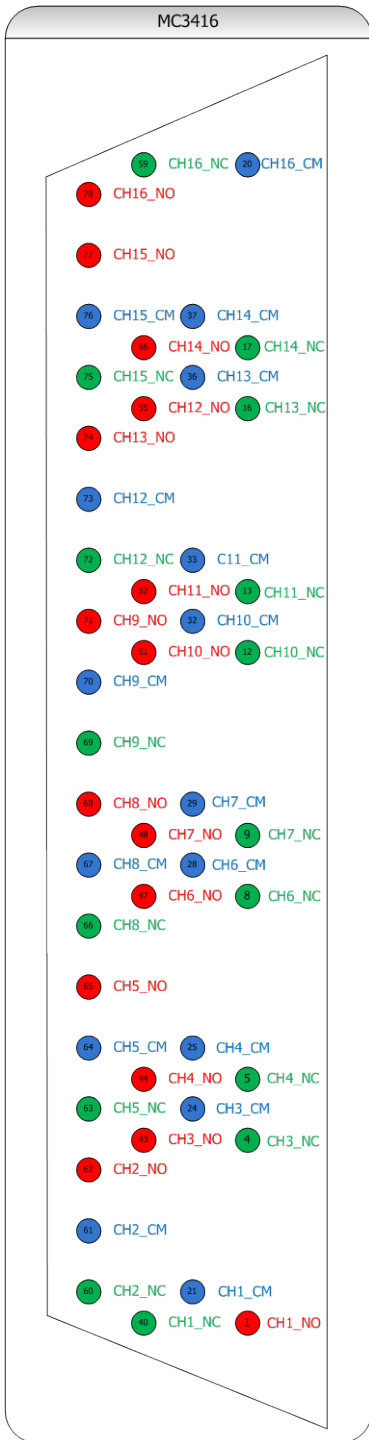

Pin Label	Pin Qty.	Definition
CHn_NC ^[1]	16	Correspond to the 16-channel NC terminal ^[2] on the external terminal block
CHn_NO ^[1]	16	Correspond to the 16-channel NO terminal ^[3] on the external terminal block
CHn_CM ^[1]	16	Correspond to the 16-channel COM terminal ^[4] on the external terminal block
Not included in the figure	30	Not used

Note^[1]: n is an integer from 01 to 16.
Note^[2]: NC refers to Normally Closed.
Note^[3]: NO refers to Normally Open.
Note^[4]: COM refers to Common.

MC3534

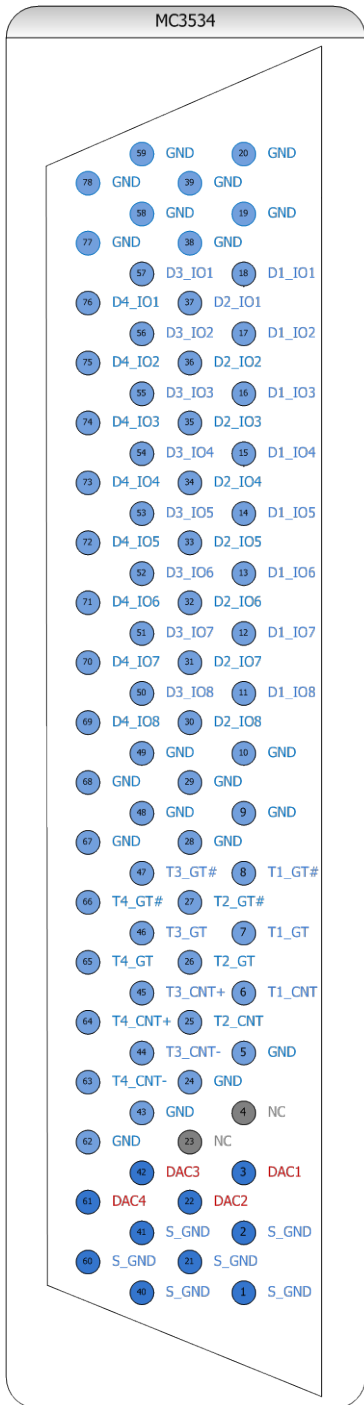

Pin Label	Pin Qty.	Definition
Dn_In ^[1]	24	Correspond to the digital input/output terminal on the external terminal block
Tm_GT# ^[2]	4	Correspond to the TOT channel input terminal on the external terminal block
Tm_GT ^[2]	4	
T3_CNT+	2	
T4_CNT+	2	
T3_CNT-	2	Correspond to the DAC channel output terminal on the external terminal block
T4_CNT-	2	
DACm ^[2]	4	Correspond to the DAC channel output terminal on the external terminal block
NC	2	Connection is forbidden
GND	20	Ground terminal
S_GND	6	Correspond to the GND terminal of the DAC channel on the external terminal block

Note^[1]: n is an integer from 01 to 08.

Note^[2]: m is an integer from 1 to 4.

- Connection forbidden
- Digital interface
- Analog input

MC3648

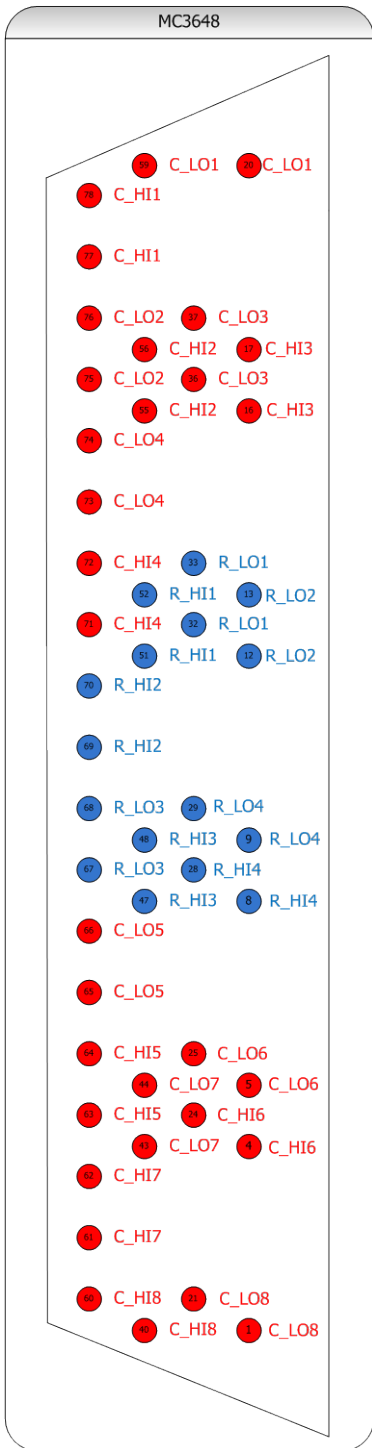

Pin Label	Pin Qty.	Definition
C_LOn ^[1]	16	Correspond to the signal input terminal on the external terminal block
C_HI ^[1]	16	
R_LOm ^[2]	8	
R_HI ^[2]	8	Not used
Not included in the figure	30	

Note^[1]: C refers to Column. n is an integer from 1 to 8.

Note^[2]: R refers to Row. m is an integer from 1 to 4.

Appendix B: Warranty

RIGOL warrants that its products mainframe and accessories will be free from defects in materials and workmanship within the warranty period.

If a product is proven to be defective within the respective period, **RIGOL** guarantees the free replacement or repair of products which are approved defective. To get repair service, please contact with your nearest **RIGOL** sales and service office.

RIGOL does not provide other warranty items except the one being provided by this warranty statement. The warranty items include but not being subjected to the hint guarantee items related to tradable characteristic and any particular purpose.

RIGOL will not take any responsibility in cases regarding to indirect, particular and ensuing damage.

Index

2WR.....	2-14	Extended copy.....	2-43
4WR.....	2-14	External Trigger.....	2-9
Absolute Time.....	2-4	Factory Settings.....	2-79
Absolute Time Trigger.....	2-10	FREQ.....	2-14
AC Filter.....	2-26	Function.....	2-14
ACV.....	2-14	Gate time.....	2-27
Advanced Configuration.....	2-20	Gateway.....	2-91
Advanced Source.....	2-4	GPIB Address.....	2-86
Alarm Channel.....	2-5, 2-18	Input Impedance.....	2-24
Alarm Condition.....	2-18	Insert the Module into the Mainframe.....	1-17
Alarm Configuration.....	2-17	Integration Time.....	2-24
Alarm Information.....	2-72	Interval.....	2-3
Alarm Limits.....	2-18	IP Address.....	2-90
Alarm Mode.....	2-18	LAN Parameters.....	2-89
Alarm Trigger.....	2-11	Latch.....	2-67
Alarm Value.....	2-18	lock the front panel.....	1-6
all channel monitor.....	2-46	MAC.....	2-91
ALPHA.....	2-31	Manual Trigger.....	2-8
Analog Bus Interface.....	1-8	ManualIP.....	2-90
Any sensor measurement.....	2-33	MC3065.....	1-18
Aperture Time.....	2-27	MC3120.....	1-18
arithmetic curve.....	2-33	MC3132.....	1-18
AutoIP.....	2-90	MC3164.....	1-18
Auto Trigger.....	2-8	MC3324.....	1-18
Auto Zero.....	2-25	MC3416.....	1-19
Bank Joined.....	2-50	MC3534.....	1-19
Bank Separate.....	2-50	MC3648.....	1-19
Brightness.....	2-85	Measurement Configuration.....	2-74
built-in help system.....	1-20	Measurement Connections.....	1-23
Channel Configuration.....	2-12	Measurement Data.....	2-75
Channel copy.....	2-41	Menu Quick Navigation.....	1-26
Channel delay.....	2-27	Mirror Configuration.....	2-75
Channel Number.....	2-13	module control.....	2-47
Cleaning.....	IX	Module copy.....	2-40
current channels.....	2-56	Module Indicators.....	1-7
DAC.....	2-63	multi-channel monitor.....	2-46
Date.....	2-78	Offset Compensation.....	2-26
DCV.....	2-14	Outside view drawing of the module.....	1-16
Decimal.....	2-83	PERIOD.....	2-14
DHCP.....	2-90	Power Switch.....	2-84
Digital Input.....	2-35	Power-off Status.....	2-81
DIO.....	2-14		
Error Information.....	2-72		

Power-on Settings	2-81	T/C Check	2-30
Preset Settings	2-81	TC	2-29
R0.....	2-31	TEMP	2-14
Range	2-23	terminal blocks	1-21
Reference Source	2-30	THER	2-29
RS-232/Alarms/Ext Trig Mixed		Time	2-78
Interface.....	1-10	To Create a New List	2-2
RTD	2-29	To Edit the List.....	2-6
RTD 4W.....	2-29	To Read the List	2-7
Scaling Configuration	2-15	To Save the List	2-7
Screen Saver.....	2-83	TOT	2-14
Select the temperature sensor type		Totalizer	2-37
.....	2-29	Track	2-67
SENSOR	2-14	Trigger Edge Type	2-5
sensor type.....	2-33	Trigger Mode	2-3
Separator.....	2-84	trigger modes	2-8
single-channel monitor	2-44	unlock the front panel.....	1-6
Slots.....	1-8	User Interface.....	1-13
Subnet Mask	2-91	View Switch.....	2-68
Sweep Count.....	2-3	Voltage Selector	1-9
System Configuration.....	2-74		